

# IPX7



鍍層厚度:

Blank: 1u"
2: 15u"
3: 30u"

### SPECIFICATIONS

#### Electrical:

1. Rating: 5.0A (V BUS&GND), 0.25A (Other Pin)
2. Voltage rating: 12V 24V AC
3. Contact Resistance: 40 mΩ Max
4. Insulation Resistance: 100 MΩ Min
5. Dielectric Withstanding Voltage: 100V AC
6. Operating temperature: -40° C ~ +85° C
7. Waterproof grade: IP-X7
8. Durability cycle: 10,000 cycles

#### Mechanical:

1. Connector Mate and Unmate Force
- 1.1 Mate force: 5~20 N.
- 1.2 Unmate force: 8~20 N

#### Material:

1. Housing: LCP
2. Contact: C18400
3. Shell: SUS
4. O-ring: Silicone

#### Finish:

1. Contact: Plated Gold in Mating Area ;  
Tin Plated on Solder Balls ;  
Nickel under plated overall
2. Shell: Nickel under Plated surface layer

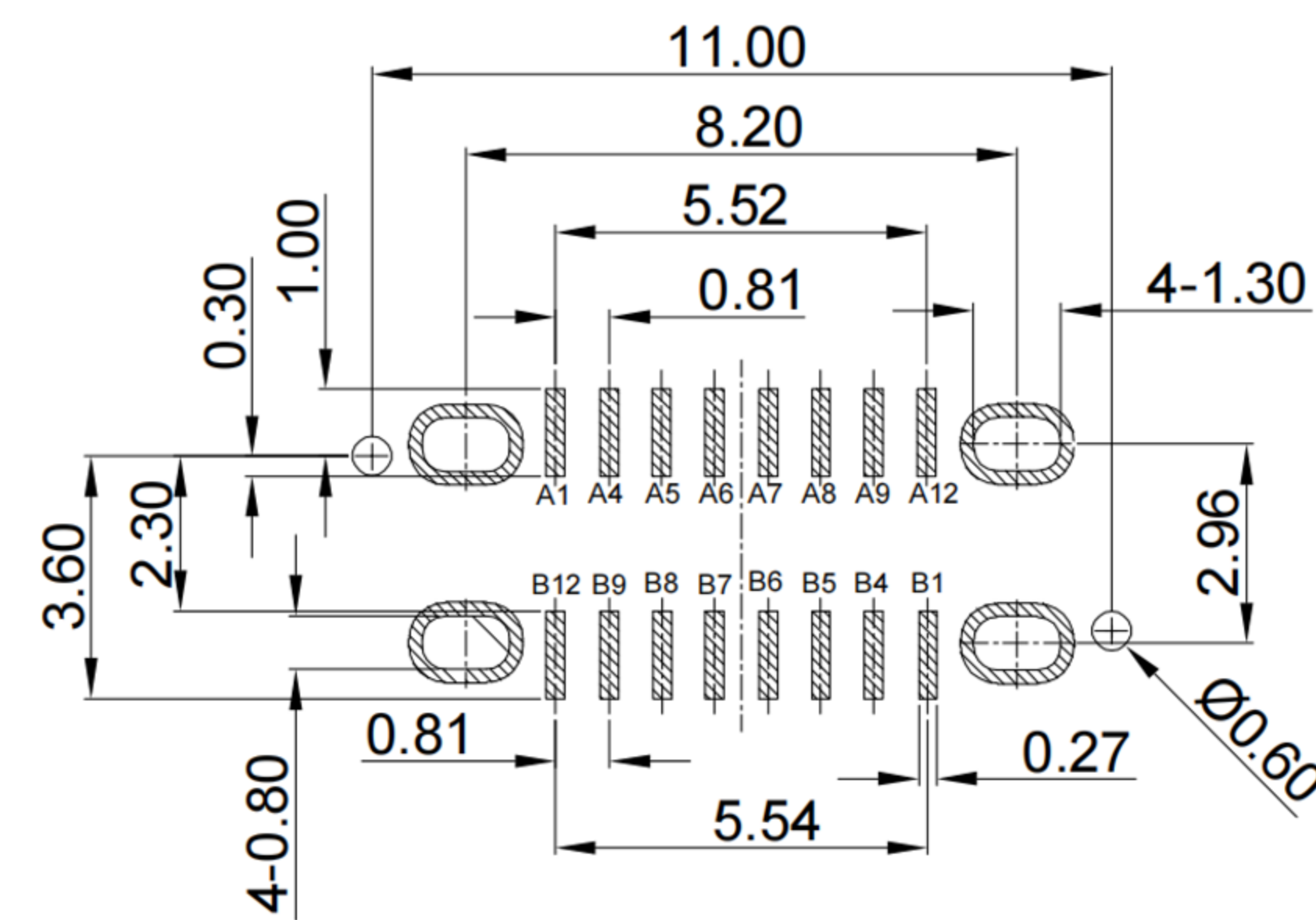
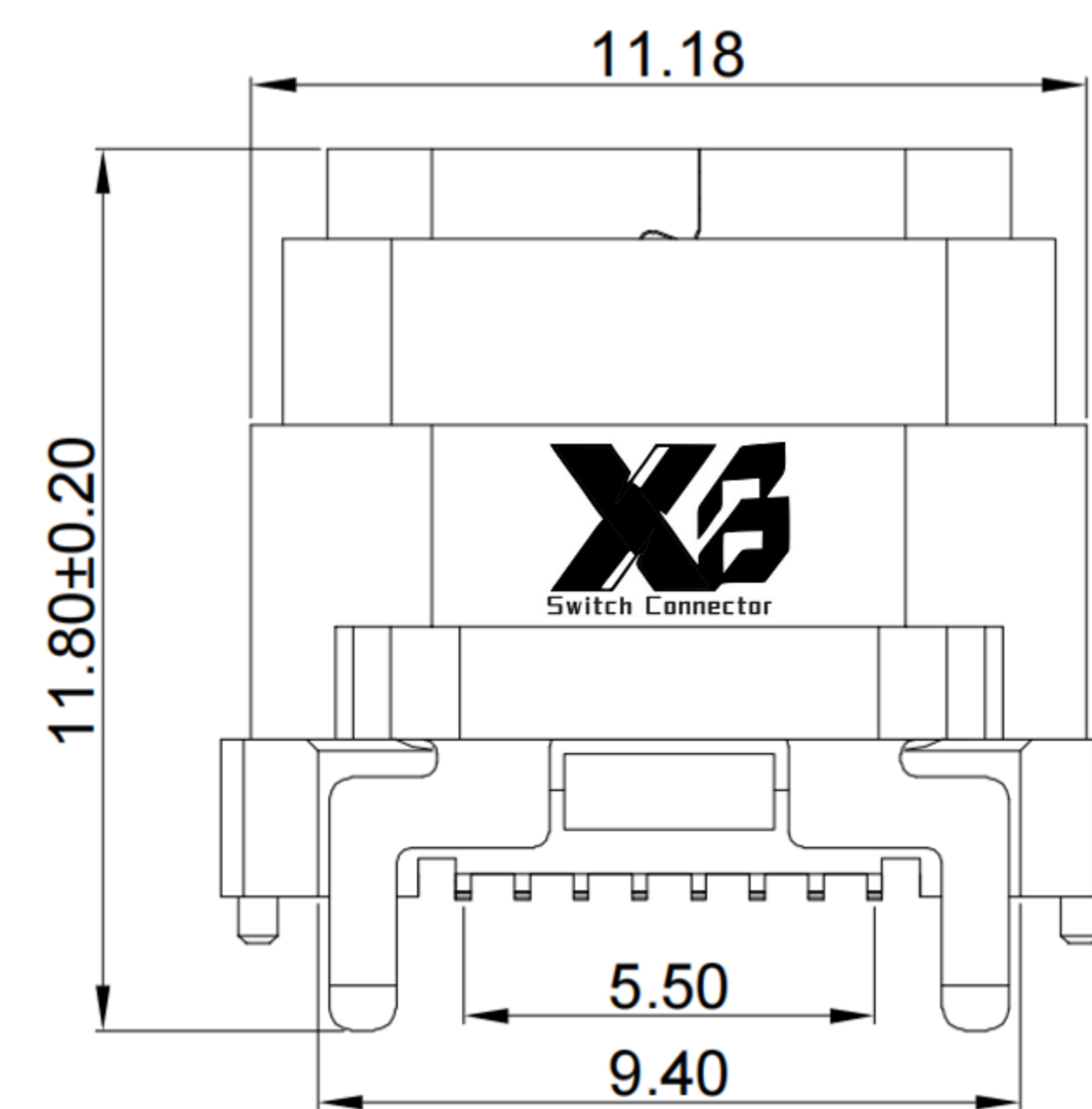
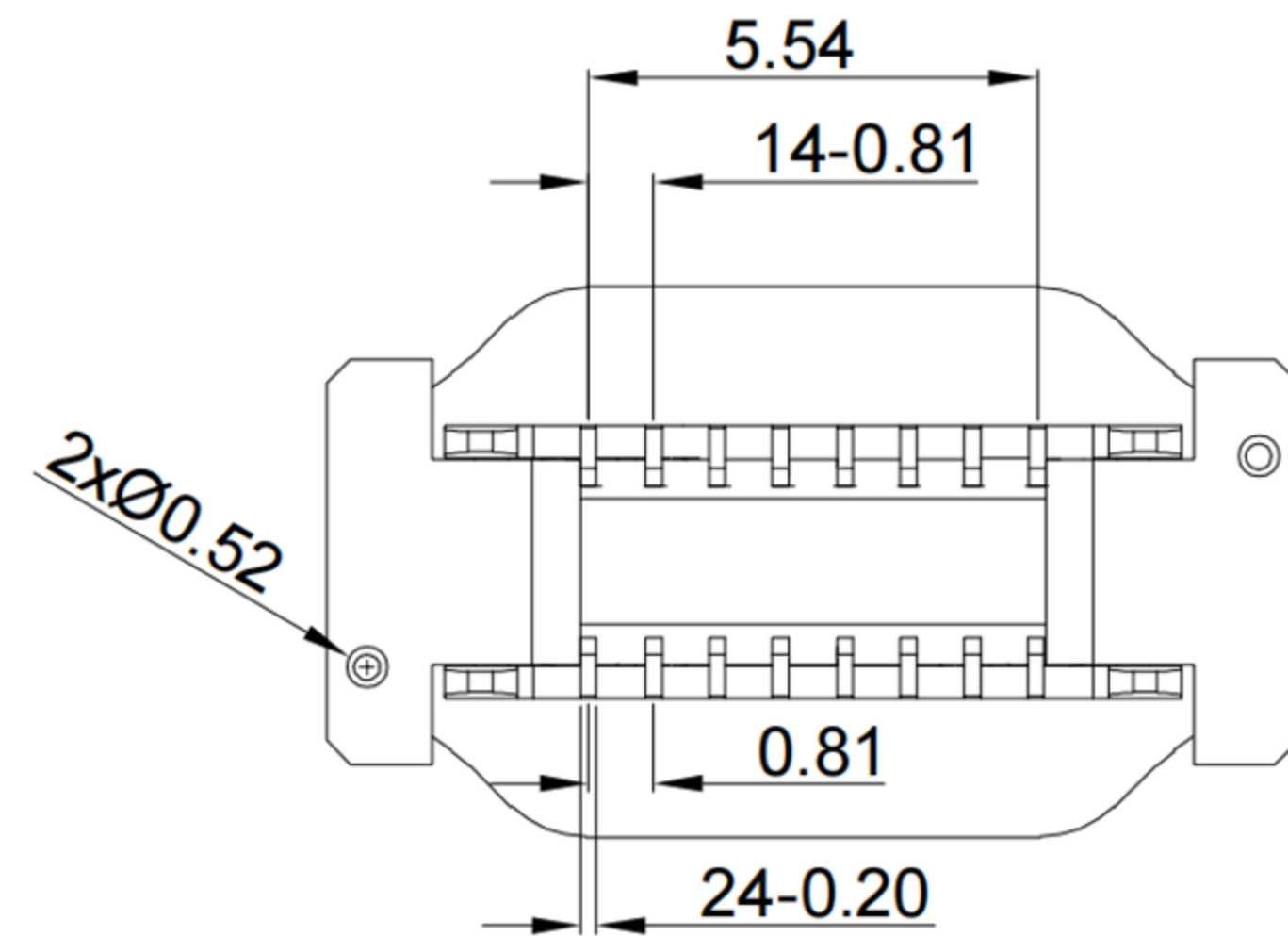
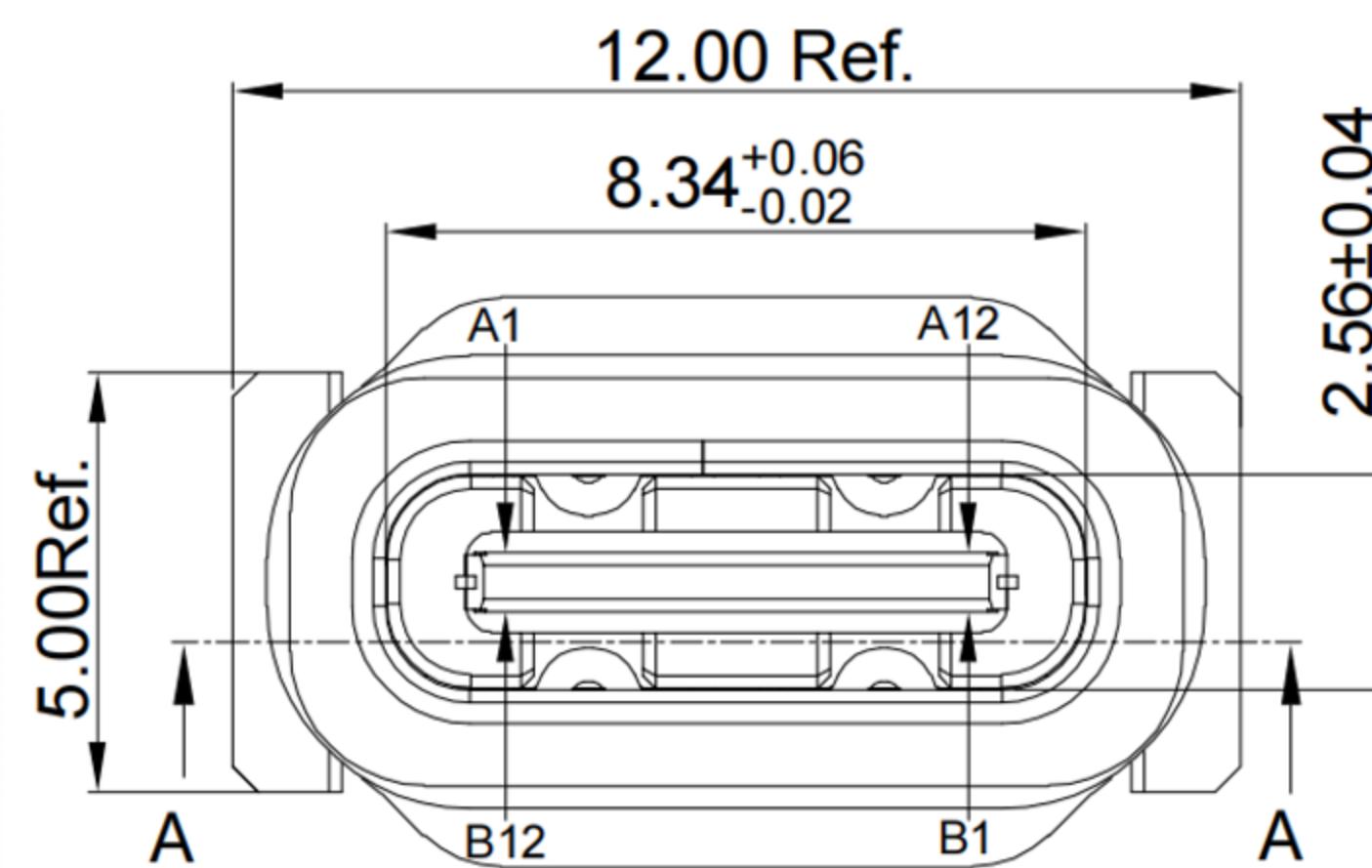

RECOMMENDED PCB LAYOUT  
TOLERANCE: ±0.05

A1	A2	A3	A4	A5	A6	A7	A8	A9	A10	A11	A12
GND			VBUS	CC1	D+	D-	SBU1	VBUS			GND
First			First	Second	Second	Second	Second	First			First
B12	B11	B10	B9	B8	B7	B6	B5	B4	B3	B2	B1
GND			VBUS	SBU2	D-	D+	CC2	VBUS			GND
First			First	Second	Second	Second	Second	First			First

**X3** 东莞市溪榜电子有限公司  
DONG GUAN XI BANG ELECTRONICS CO., LTD.

TOLERANCE UNLESS OTHERWISE STATED:

Up to 5 ±0.2  
Above 5 ~ 15 ±0.3  
Above 15 ~ 30 ±0.4  
Above 30 ~ 50 ±0.5  
Angle ±0.3°

3RD. ANGEL'S

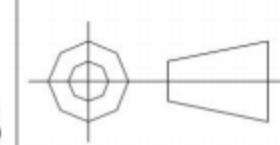

UNITS

MM

DRAWN BY: Jack Lu  
CHECKED BY: Jacky Chen  
APPROVED BY: Tony Kao

DATE: 03/10/22  
DATE: 03/10/22  
DATE: 03/10/22

MAT'L  
FINISH  
SCALE: 1:1  
SHEET NO. 1 of 1

TITLE: CONNECTOR  
MODLE: Vertical Type-c 16P Female SMT H=10.0mm  
DWG NO. XB-USB-C-1621-FS  
PART NO.

SIZE: A4  
VER: R1

1	更新圖面	Jack	031022
ITEM NO.	DESCRIPTION	DRAWN	DATE



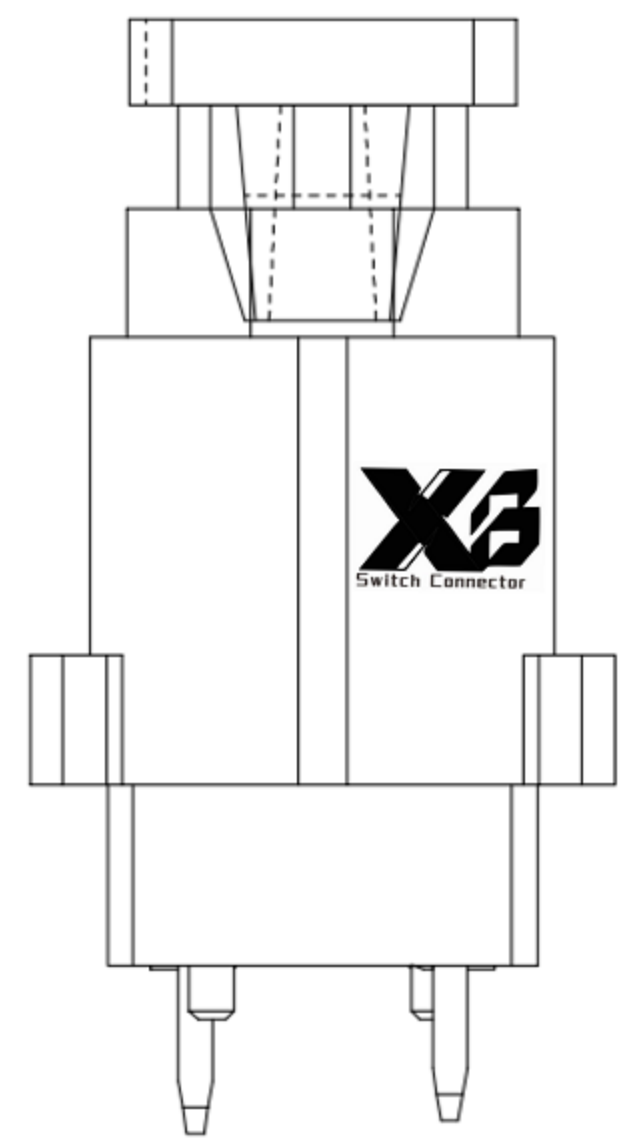

Schematic diagram of adding Cap

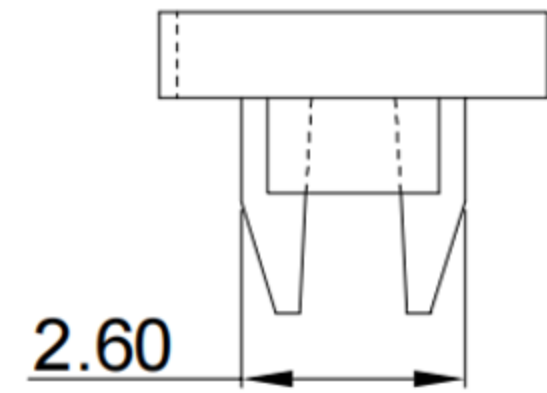
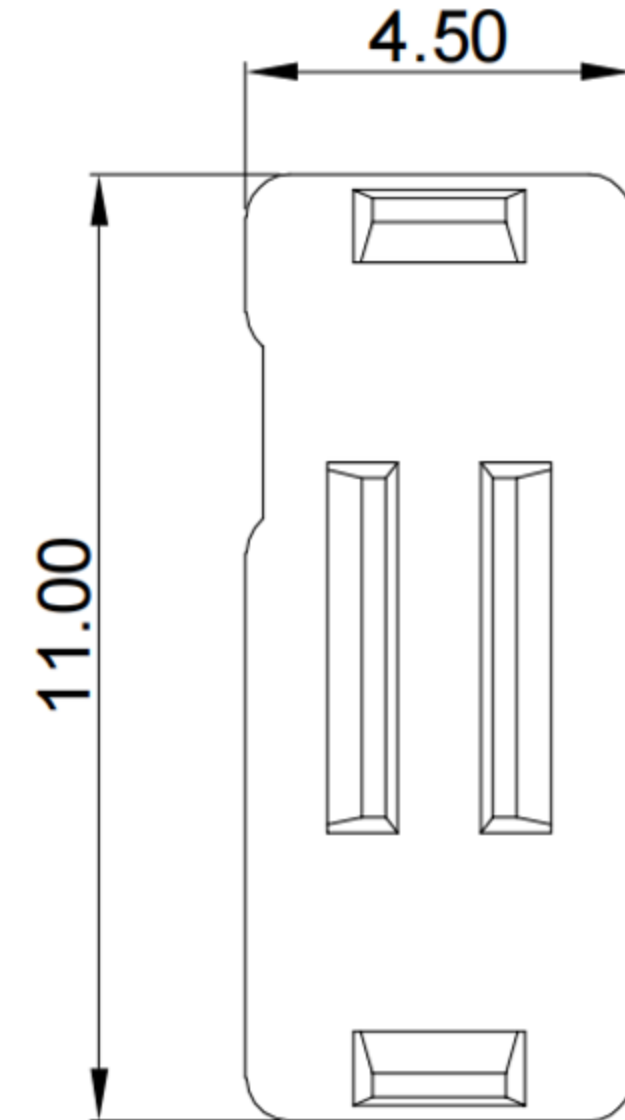

Schematic diagram of adding water-proof ring

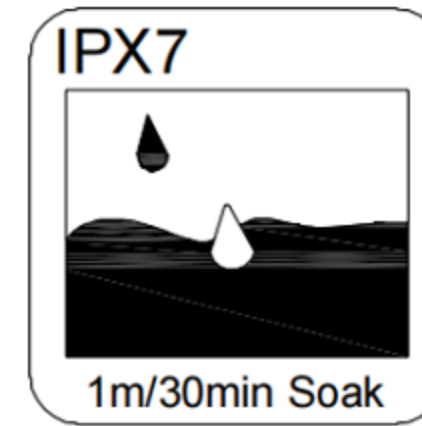
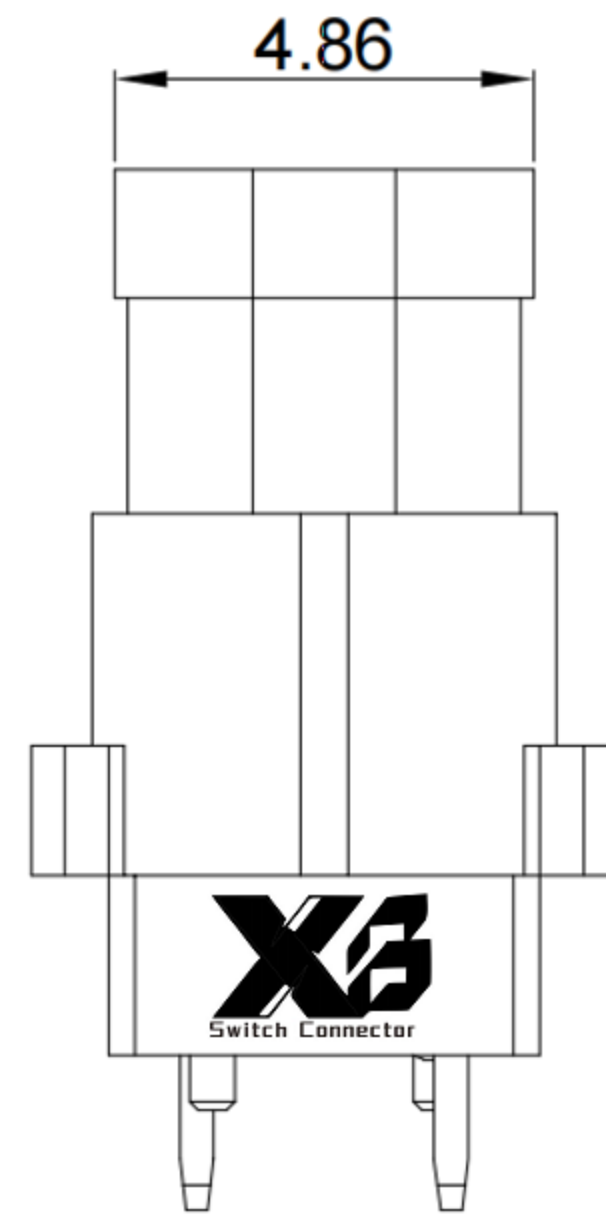
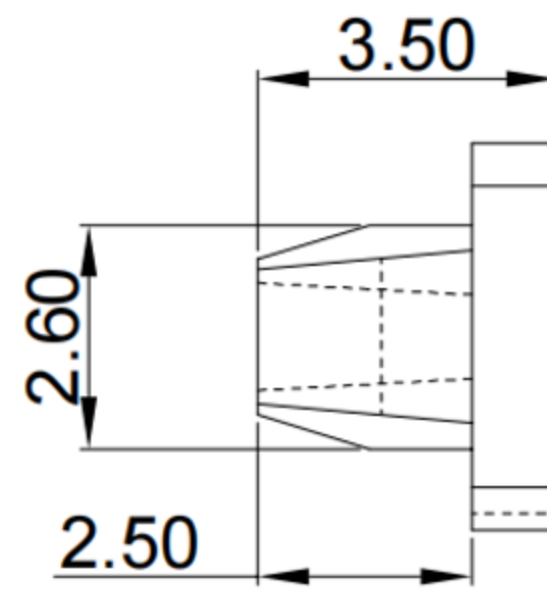
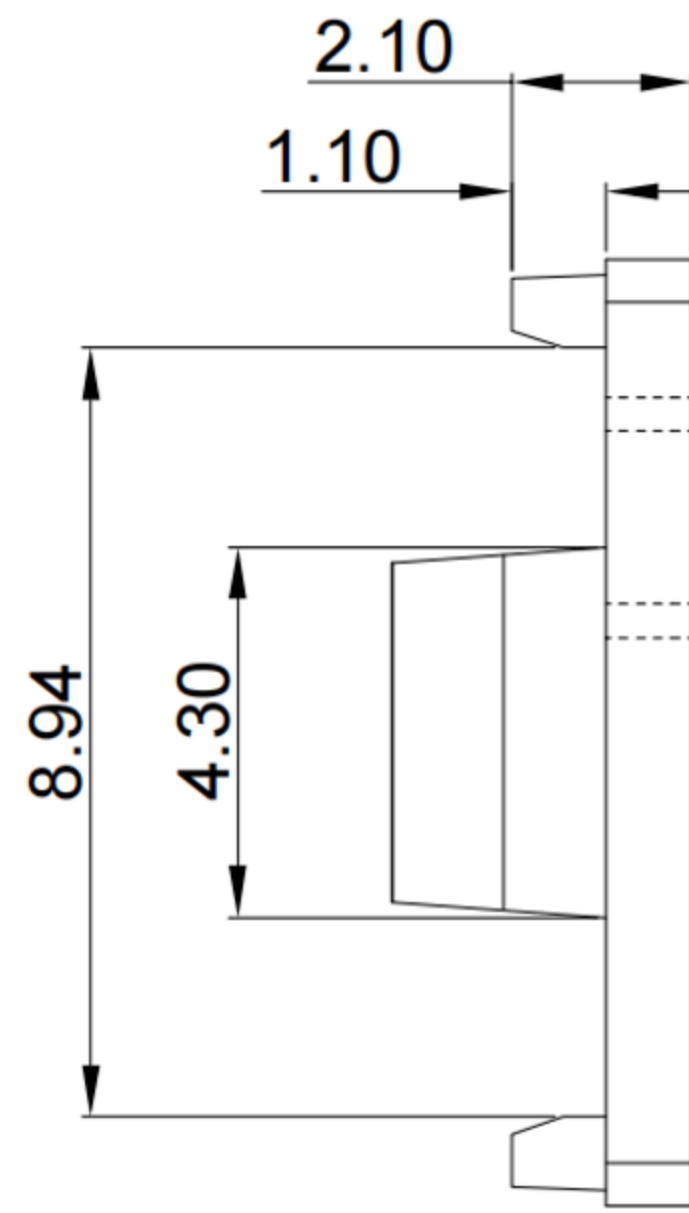
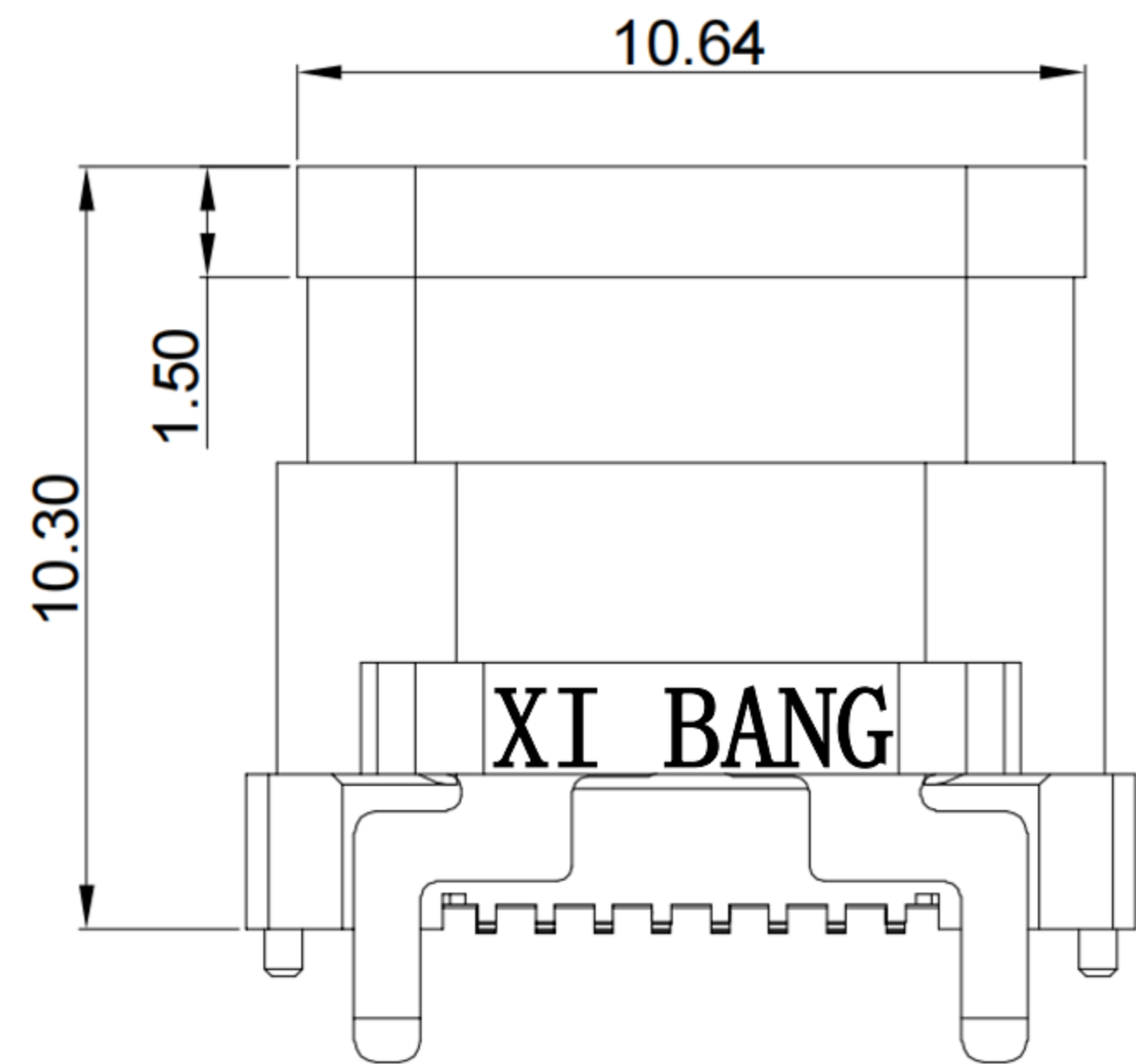

IPX7



**SPECIFICATIONS**

**Electrical:**

1. Rating: 5.0A (V BUS&GND), 0.25A(Other Pin)
2. Voltage rating: 12V 24V AC
3. Contact Resistance: 40 mΩ Max
4. Insulation Resistance: 100 MΩ Min
5. Dielectric Withstanding Voltage: 100V AC
6. Operating temperature: -40° C ~ +85° C
7. Waterproof grade: IP-X7
8. Durability cycle: 10,000 cycles

**Mechanical:**

1. Connector Mate and Unmate Force
  - 1.1 Mate force: 5~20 N .
  - 1.2 Unmate force: 8~20 N

**Material:**

1. Housing: LCP
2. Contact: C18400
3. Shell: SUS
4. O-ring: Silicone

**Finish:**

1. Contact: Plated Gold in Mating Area ;  
Tin Plated on Solder Balls ;  
Nickel under plated overall
2. Shell: Nickel under Plated surface layer

**XB** 东莞市溪榜电子有限公司  
DONG GUAN XI BANG ELECTRONICS CO., LTD.

TOLERANCE UNLESS OTHERWISE STATED:  
Up to 5 ±0.2  
Above 5 ~ 15 ±0.3  
Above 15 ~ 30 ±0.4  
Above 30 ~ 50 ±0.5  
Angle ±0.3°

3RD. ANGEL'S

UNITS MM

DRAWN BY:	DATE	MAT'L	TITLE	CONNECTOR
Jack Lu	03/10/22			
CHECKED BY:	DATE	FINISH	MODLE	Vertical Type-c 16P Female SMT H=10.0mm
Jacky Chen	03/10/22			
APPROVED BY:	DATE	SCALE	DWG NO.	XB-USB-C-1621-FS
Tony Kao	03/10/22	1:1		
		SHEET NO.	PART NO.	
		1 of 1		

1	更新圖面	Jack	031022
ITEM NO.	DESCRIPTION	DRAWN	DATE