

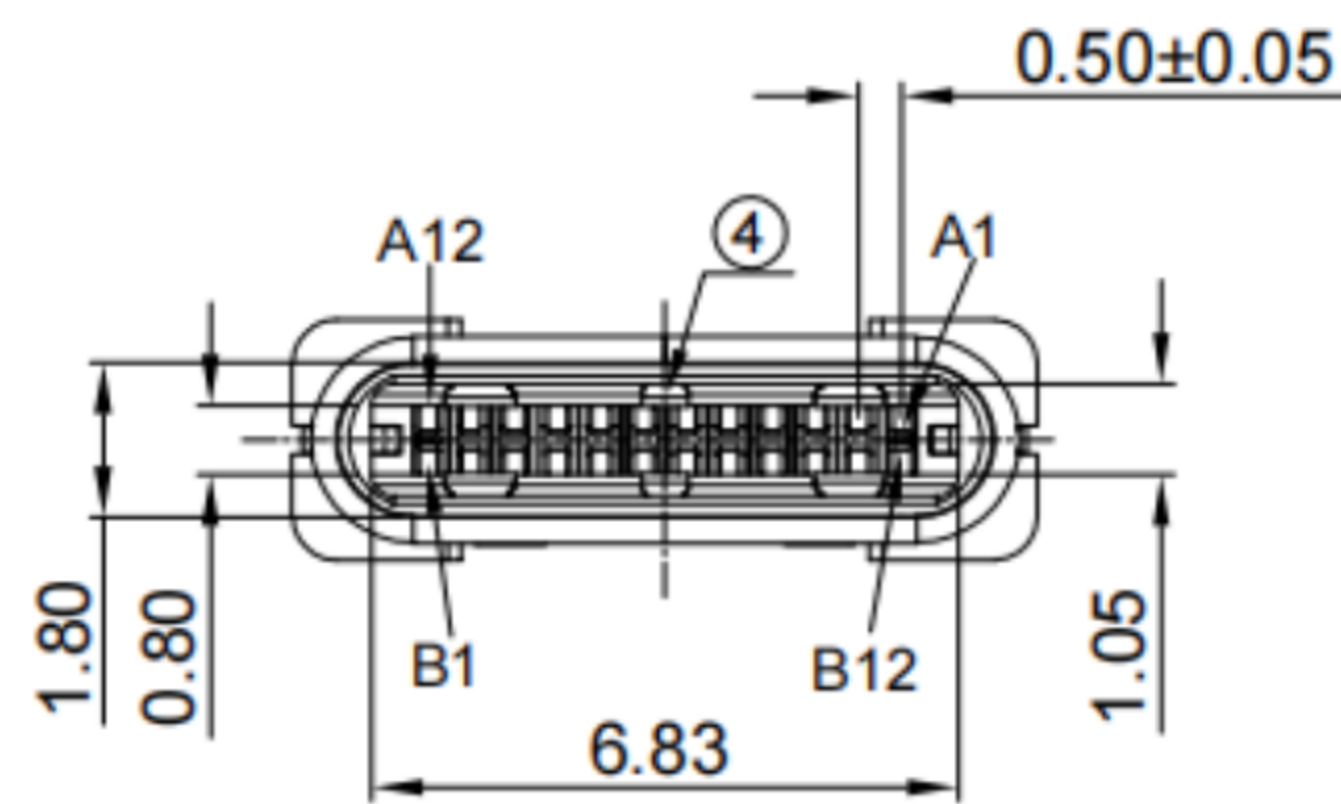

鍍層厚度:

Blank : 1u"
2 : 15u"
3 : 30u"

A12	A11	A10	A9	A8	A7	A6	A5	A4	A3	A2	A1
GND	RX2+	RX2-	VBUS	SBU1	D-	D+	CC1	VBUS	TX1-	TX1+	GND
First	Second	Second	First	Second	Second	Second	Second	First	Second	Second	First
B1	B2	B3	B4	B5	B6	B7	B8	B9	B10	B11	B12
GND	TX2+	TX2-	VBUS	VCONN	D+	D-	SBU2	VBUS	RX1-	RX1+	GND
First	Second	Second	First	Second	Second	Second	Second	First	Second	Second	First

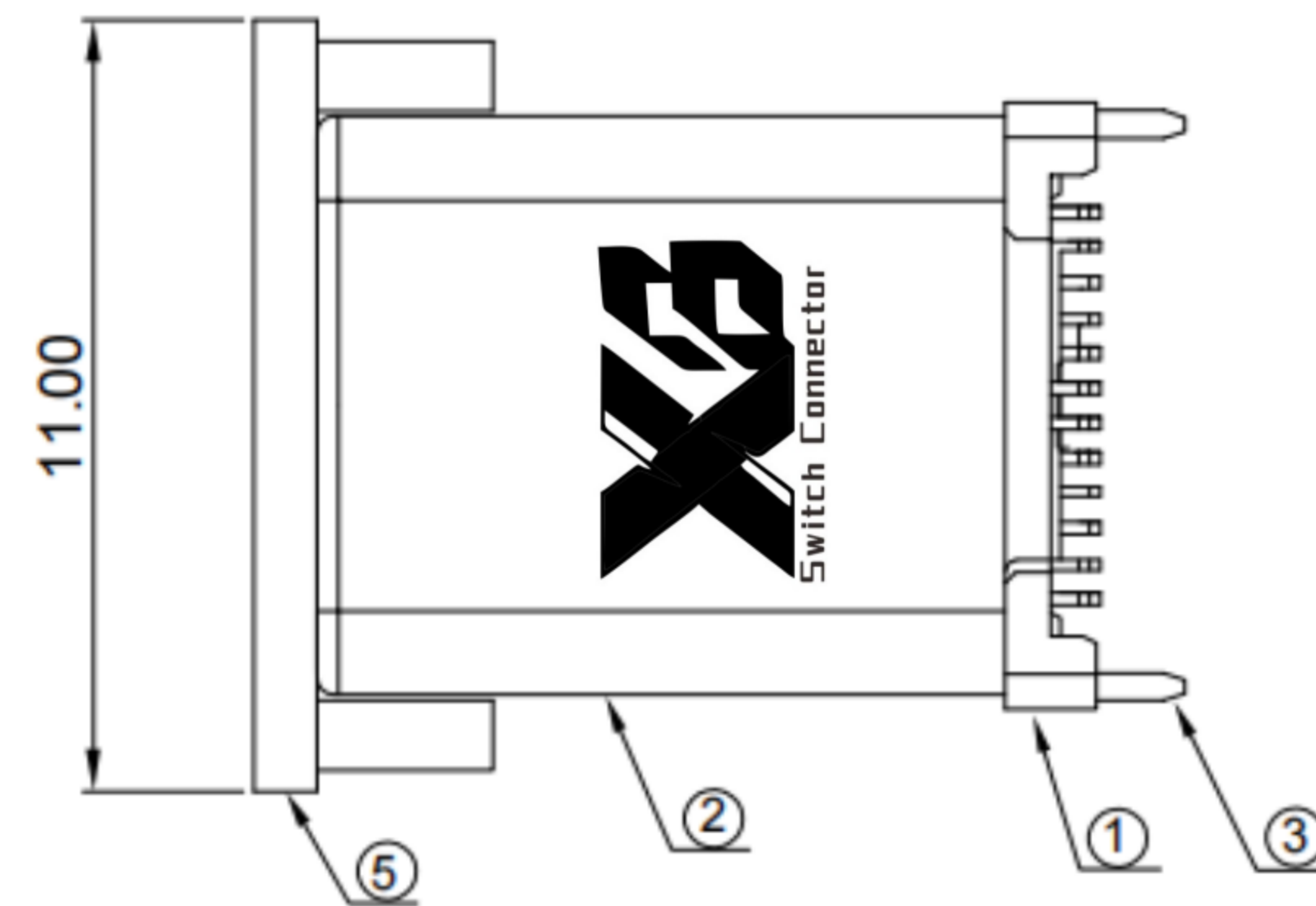
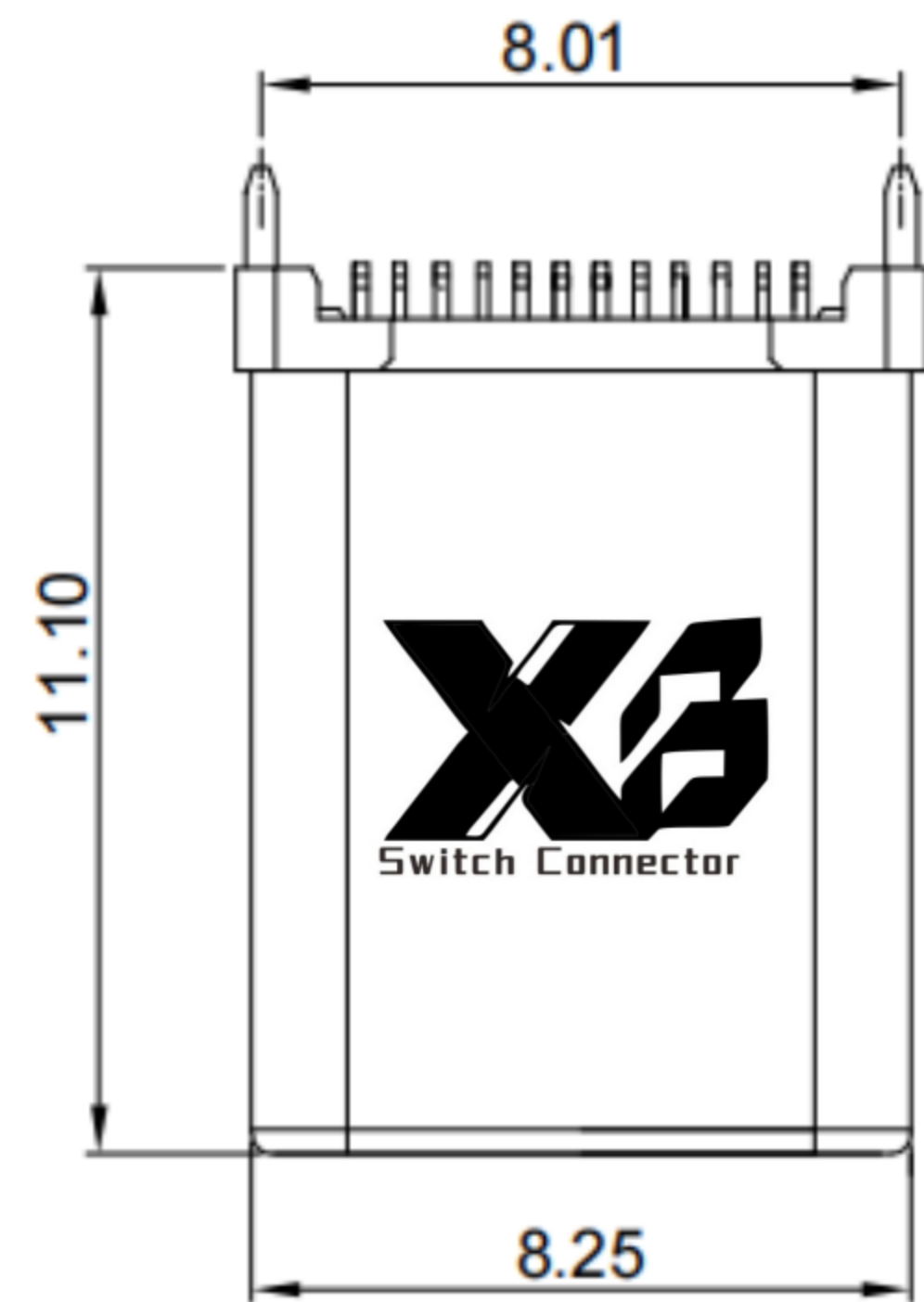

SPECIFICATIONS

Electrical:

1. Rating: 3.0A (V BUS&GND), 0.25A (Other Pin)
2. Voltage rating: 12V 24V AC
3. Contact Resistance: 40 mΩ Max
4. Insulation Resistance: 100 MΩ Min
5. Dielectric Withstanding Voltage: 100V AC
6. Operating temperature: -40° C ~ +85° C
7. Waterproof grade: IP 50
8. Durability cycle: 10,000 cycles

Mechanical:

1. Connector Mate and Unmate Force
 - 1.1 Mate force: 5~20 N .
 - 1.2 Unmate force: 8~20 N

Material:

1. Housing: LCP
2. Contact: C18400
3. Shell: SUS
4. O-ring: Silicone

Finish:

1. Contact: Plated Gold in Mating Area ;
Tin Plated on Solder Balls ;
Nickel under plated overall
2. Shell: Nickel under Plated surface layer

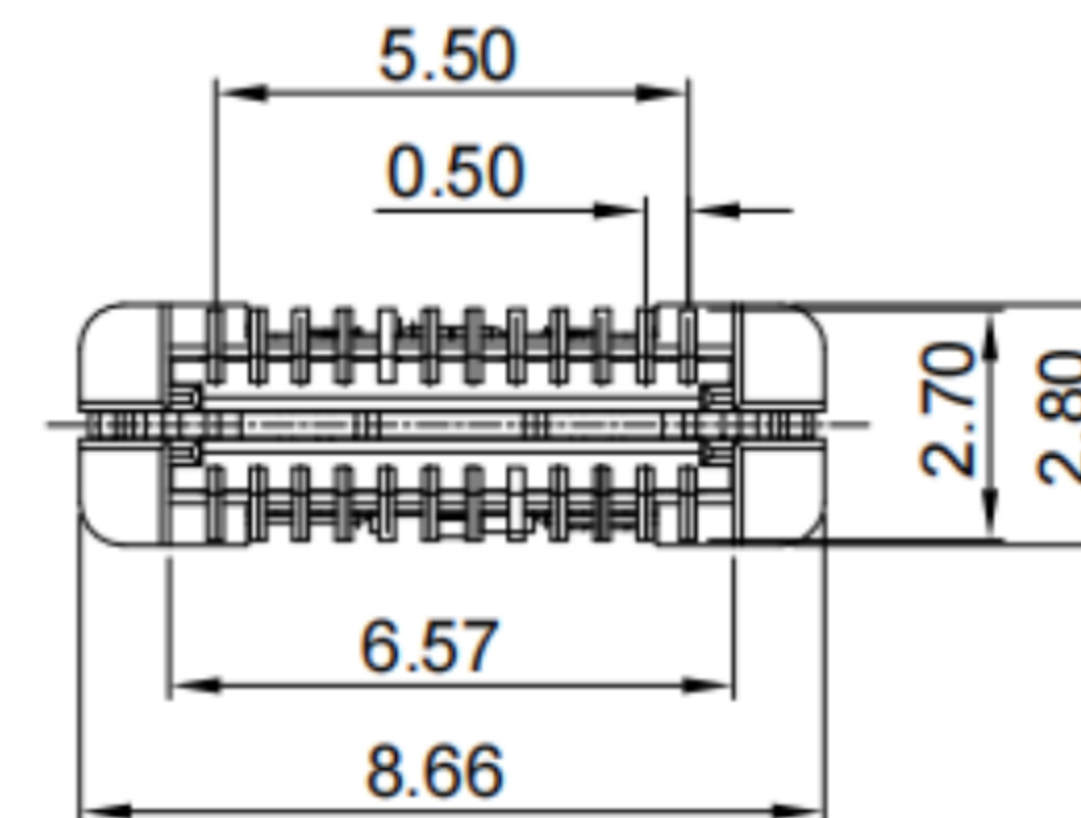
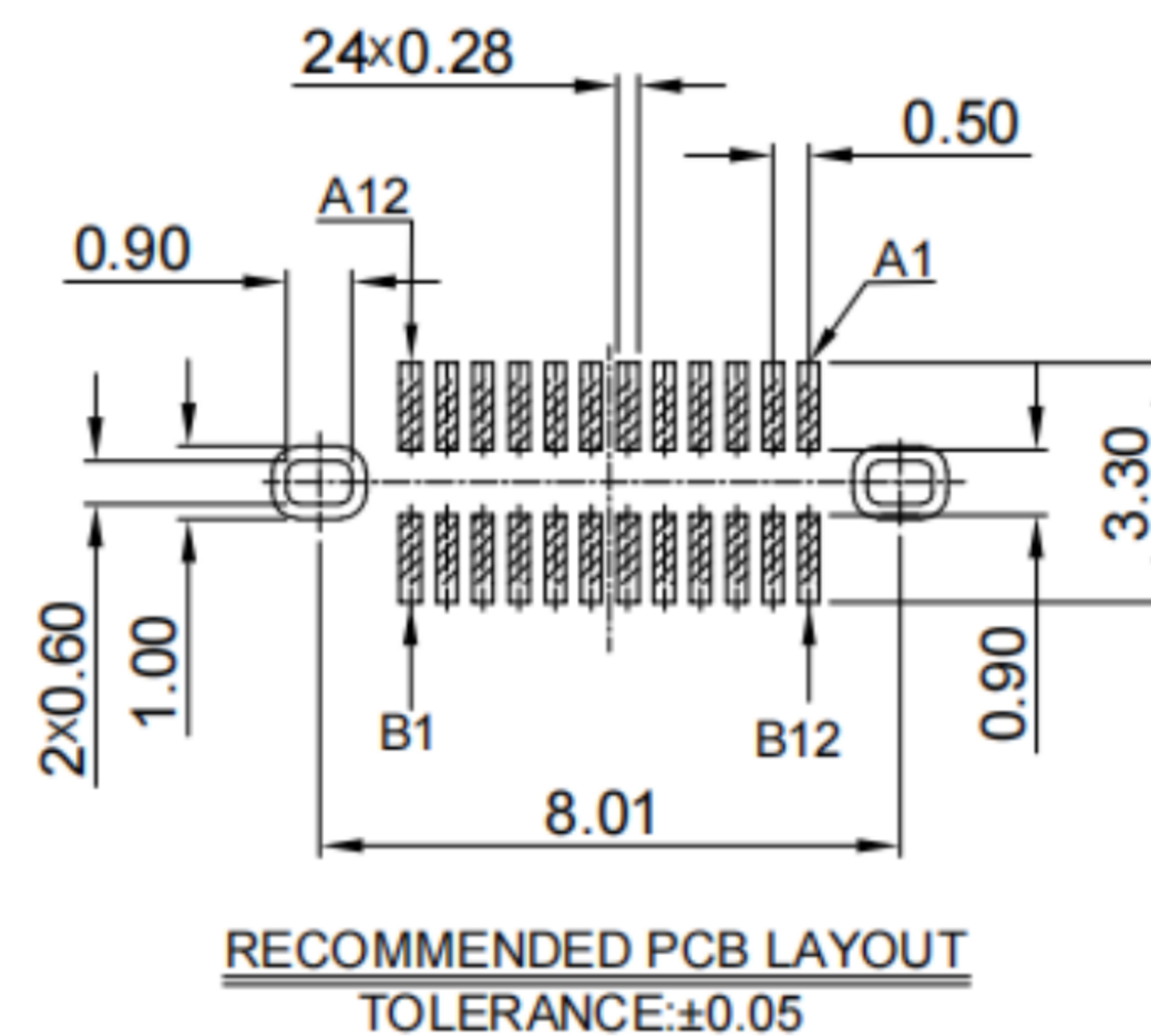
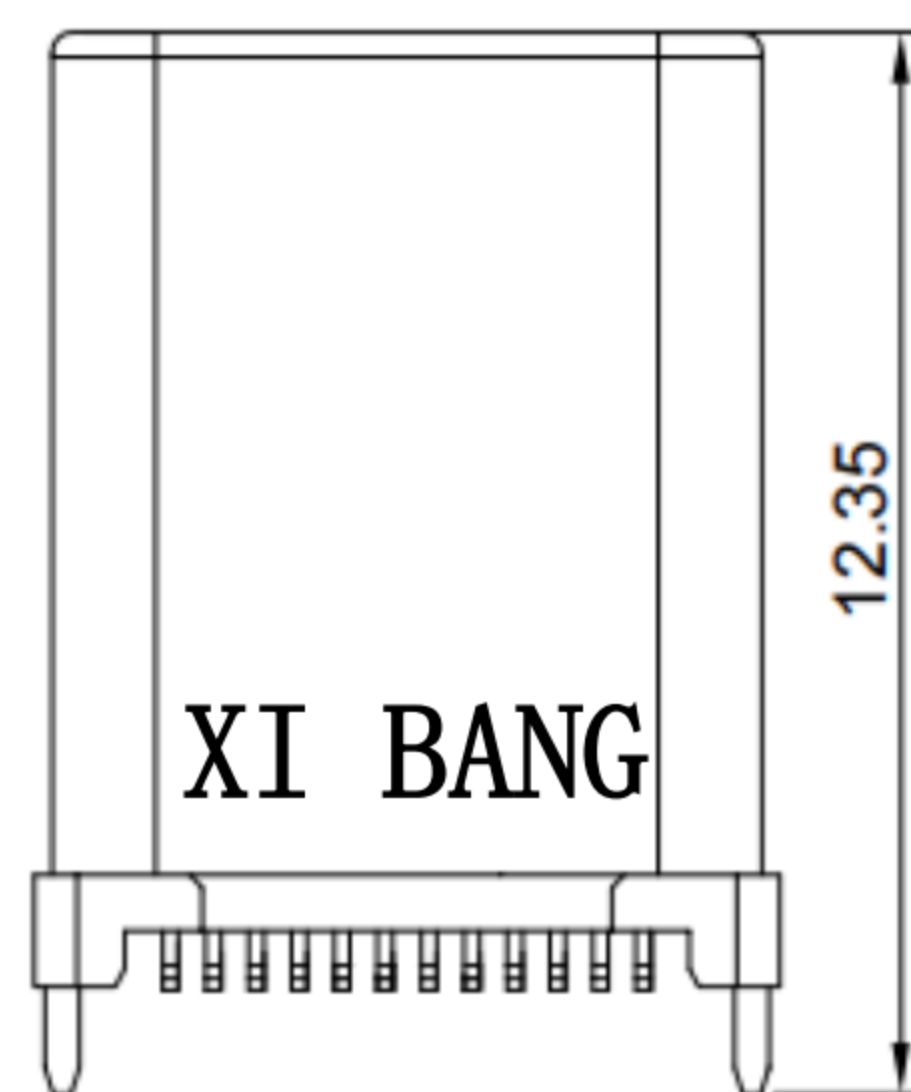

XI BANG 东莞市溪榜电子有限公司
DONG GUAN XI BANG ELECTRONICS CO., LTD.

TOLERANCE UNLESS OTHERWISE STATED:

Up to 5 ±0.2
Above 5 ~ 15 ±0.3
Above 15 ~ 30 ±0.4
Above 30 ~ 50 ±0.5
Angle ±0.3°

3RD. ANGEL'S

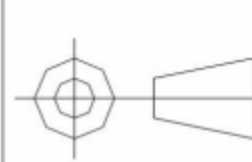

UNITS MM

DRAWN BY: Jack Lu
DATE: 03/10/22
CHECKED BY: Jacky Chen
DATE: 03/10/22
APPROVED BY: Tony Kao
DATE: 03/10/22

MAT'L	TITLE	CONNECTOR
FINISH	MODLE	Vertical Type-c 24P Plug SMT L=11.1mm
SCALE	DWG NO.	XB-USB-C-T-2403A
SHEET NO.	PART NO.	

1	更新圖面	Jack	031022
ITEM NO.	DESCRIPTION	DRAWN	DATE

SIZE A4
VER R1