

IPX7



鍍層厚度:

Blank	: 1u"
2	: 15u"
3	: 30u"

SPECIFICATIONS

Electrical:

1. Rating: 5.0A (V BUS&GND), 0.25A (Other Pin)
2. Voltage rating: 12V 24V AC
3. Contact Resistance: 40 mΩ Max
4. Insulation Resistance: 100 MΩ Min
5. Dielectric Withstanding Voltage: 100V AC
6. Operating temperature: -40° C ~ +85° C
7. Waterproof grade: IP-X7
8. Durability cycle: 10,000 cycles

Mechanical:

1. Connector Mate and Unmate Force
 - 1.1 Mate force: 5~20 N.
 - 1.2 Unmate force: 8~20 N

Material:

1. Housing: LCP
2. Contact: C18400
3. Shell: SUS
4. O-ring: Silicone

Finish:

1. Contact: Plated Gold in Mating Area ;
Tin Plated on Solder Balls ;
Nickel under plated overall
2. Shell: Nickel under Plated surface layer

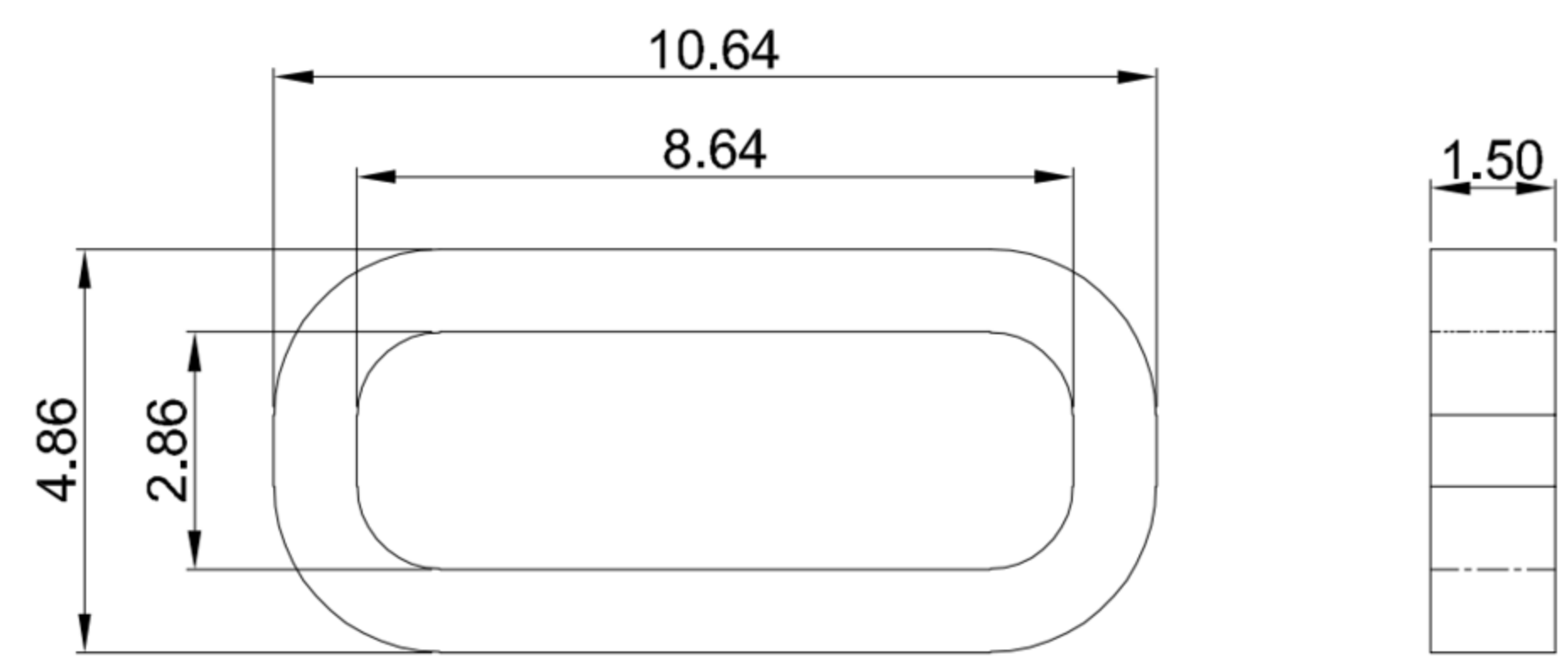
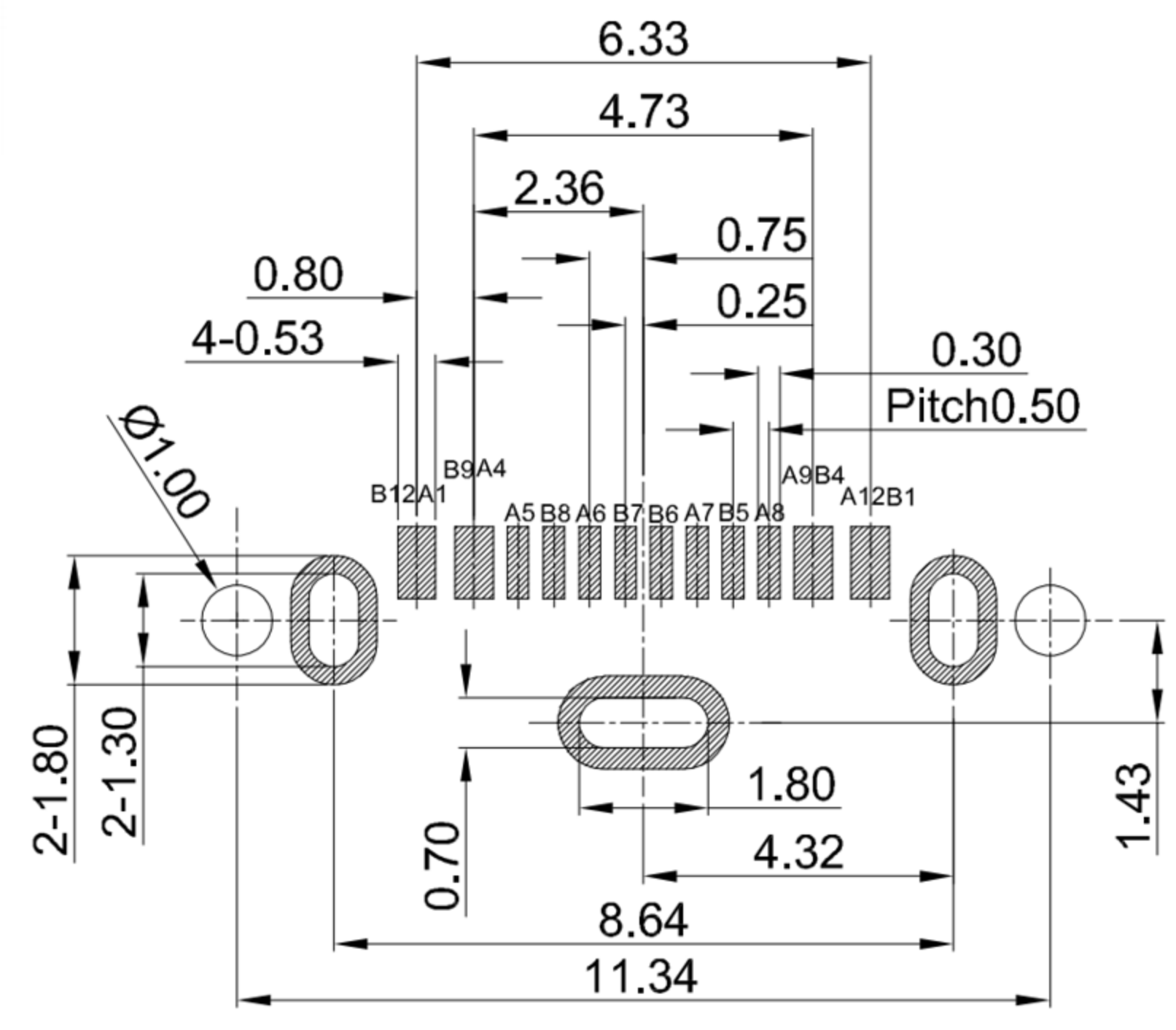
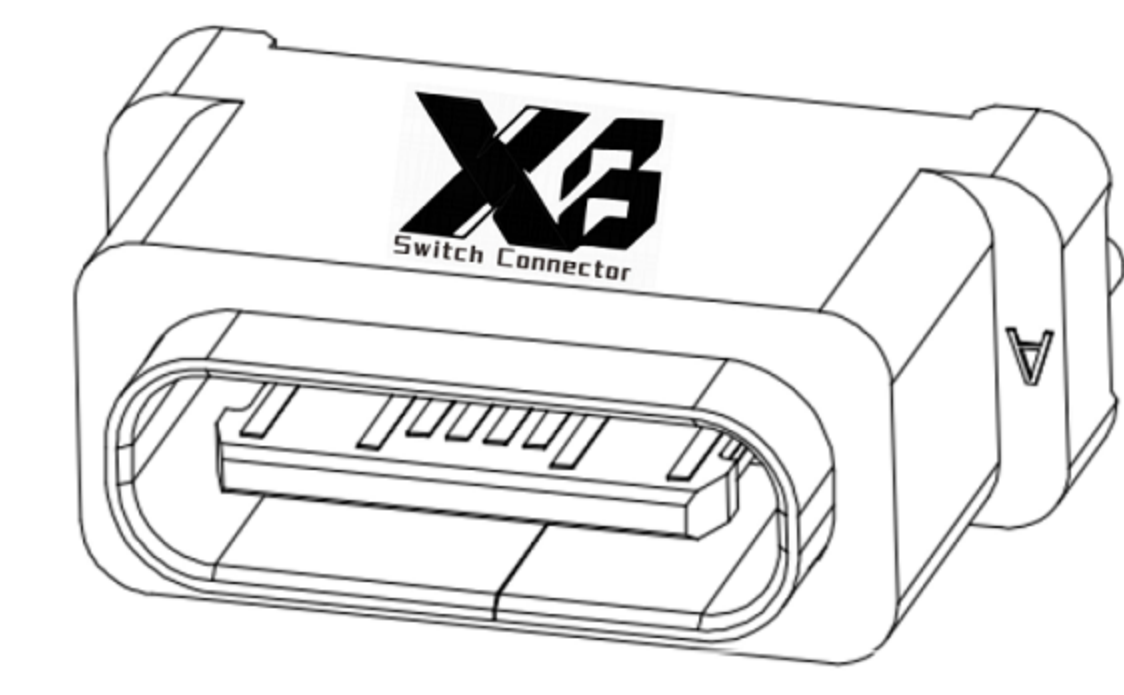
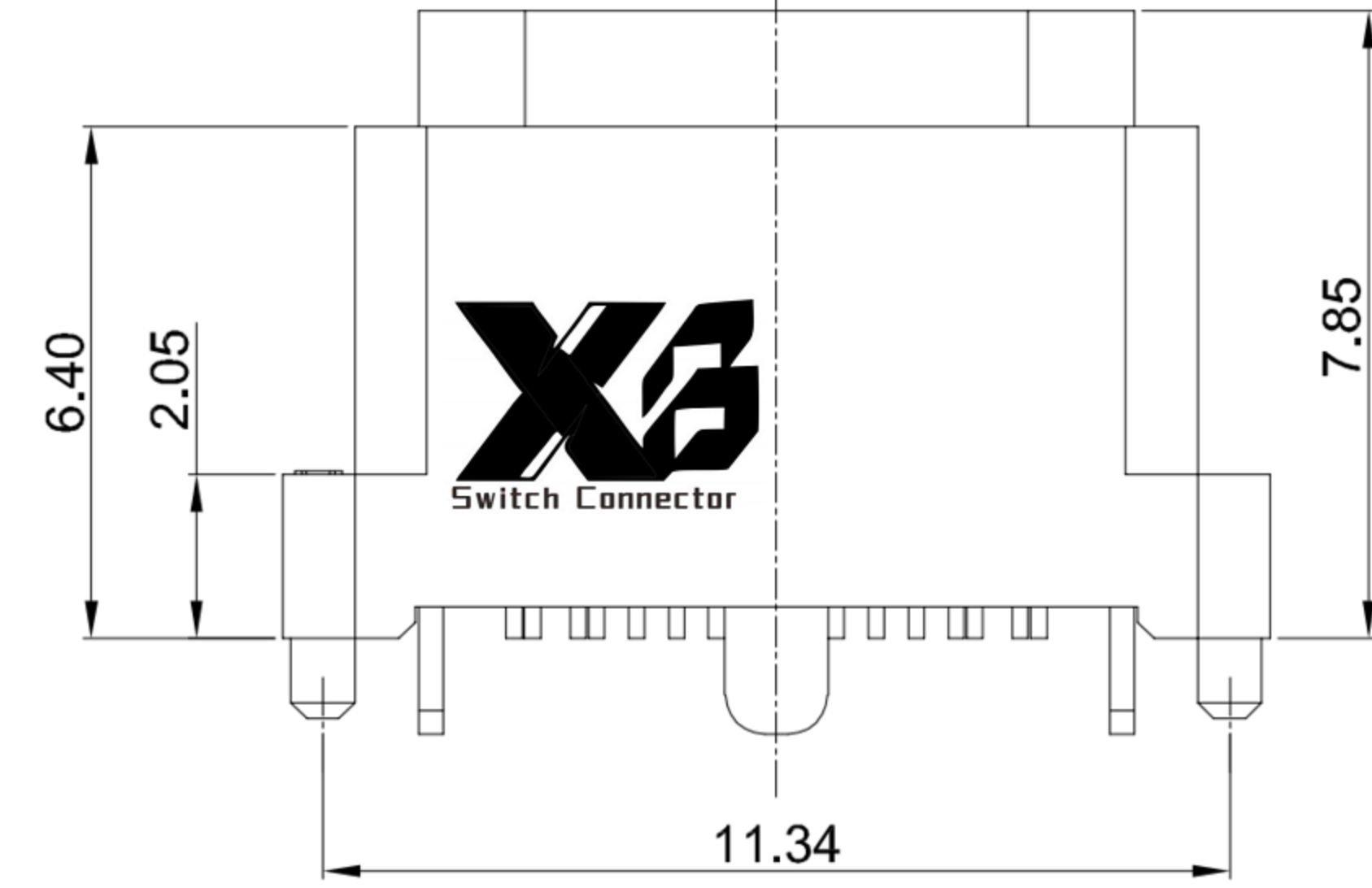
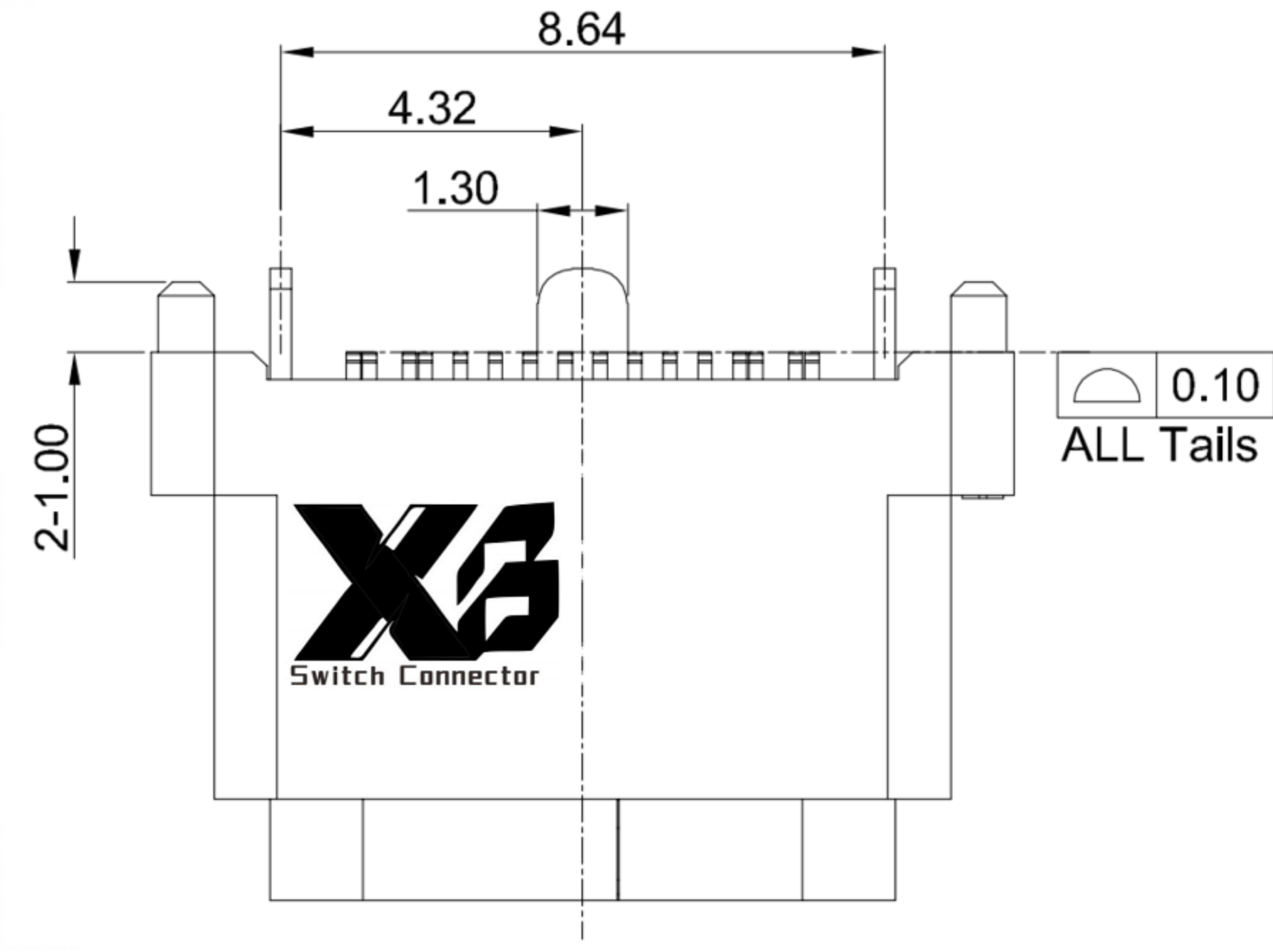

SUGGESTED RUBBER RING SIZE

RECOMMENDED PCB LAYOUT
TOLERANCE: ±0.05

A1	A2	A3	A4	A5	A6	A7	A8	A9	A10	A11	A12
GND			VBUS	CC1	D+	D-	SBU1	VBUS			GND
First			First	Second	Second	Second	Second	First			First
B12	B11	B10	B9	B8	B7	B6	B5	B4	B3	B2	B1
GND			VBUS	SBU2	D-	D+	CC2	VBUS			GND
First			First	Second	Second	Second	Second	First			First

东莞市溪榜电子有限公司
DONG GUAN XI BANG ELECTRONICS CO., LTD.

TOLERANCE UNLESS OTHERWISE STATED:	Up to 5 ±0.2	Above 5 ~ 15 ±0.3	Above 15 ~ 30 ±0.4	Above 30 ~ 50 ±0.5	Angle ±0.3°
	3RD. ANGEL'S				
		UNITS	MM		

DRAWN BY:	DATE	MAT'L	TITLE	CONNECTOR
Jack Lu	03/10/22			
CHECKED BY:	DATE	FINISH	MODLE	Vertical Type-c 16P Female DIP H=7.85mm
Jacky Chen	03/10/22			
APPROVED BY:	DATE	SCALE	DWG NO.	XB-USB-C-1611-FS
Tony Kao	03/10/22	1:1	PART NO.	
		SHEET NO.	1 of 1	
				SIZE A4
				VER R1

1	更新圖面	Jack	031022
ITEM NO.	DESCRIPTION	DRAWN	DATE

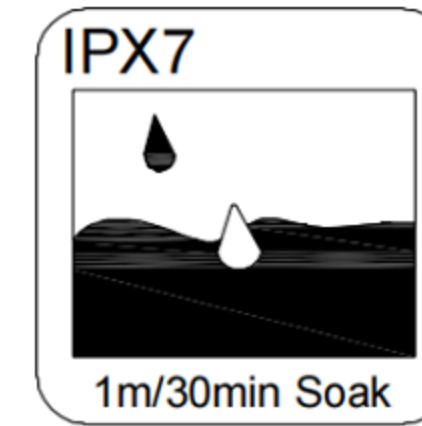
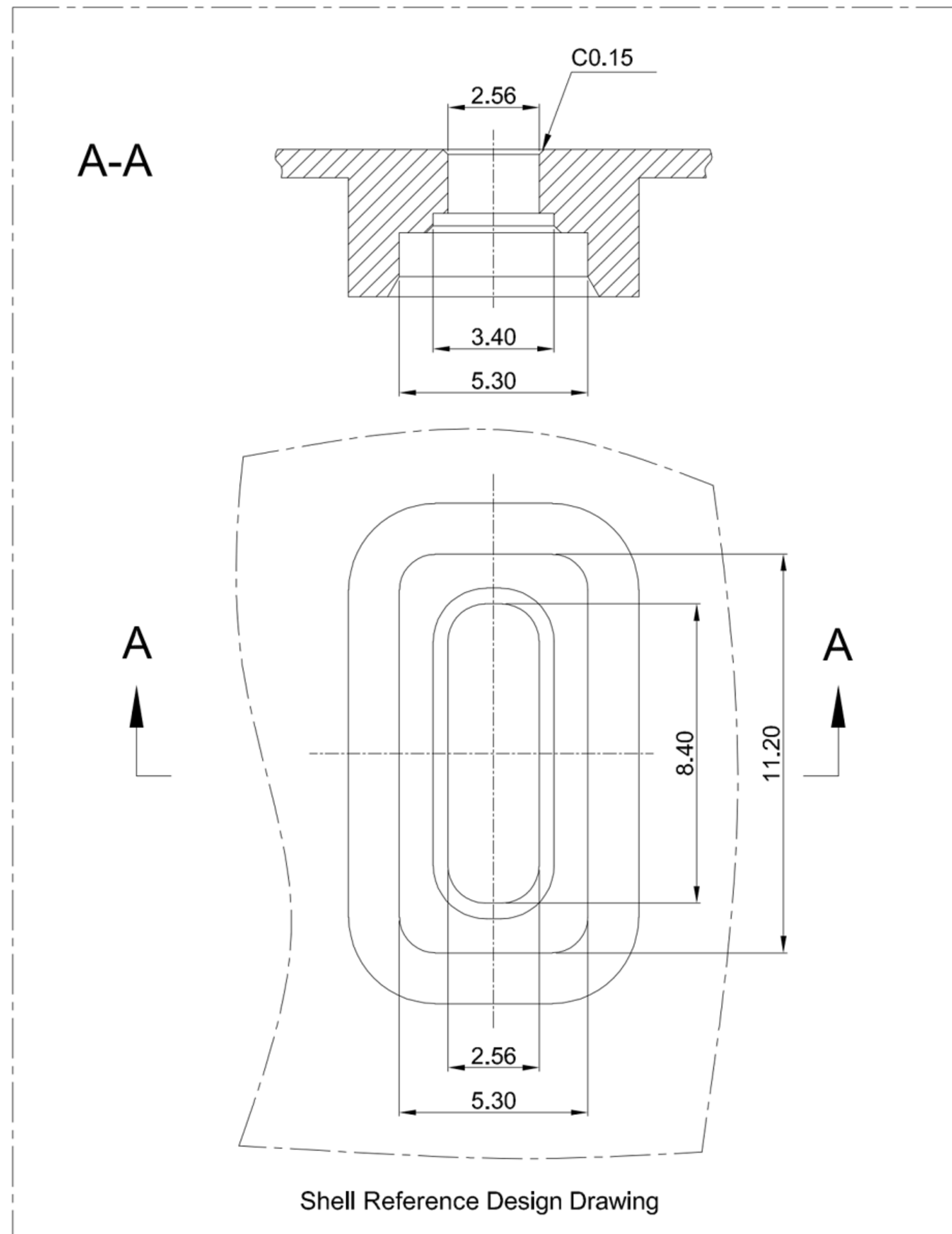
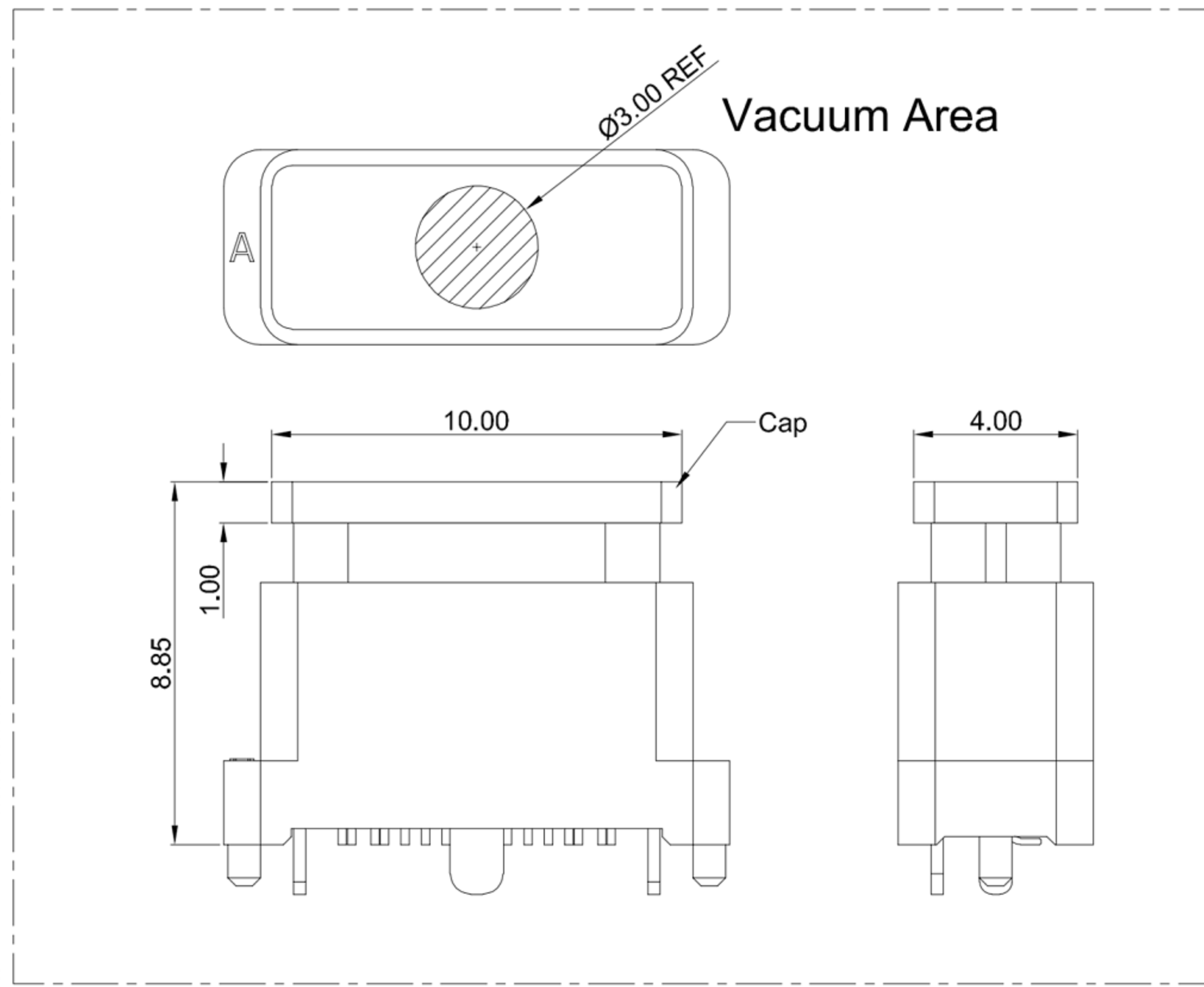

IPX7



鍍層厚度:

Blank : 1u"
2 : 15u"
3 : 30u"

SPECIFICATIONS

Electrical:

1. Rating: 5.0A (V BUS&GND), 0.25A (Other Pin)
2. Voltage rating: 12V 24V AC
3. Contact Resistance: 40 mΩ Max
4. Insulation Resistance: 100 MΩ Min
5. Dielectric Withstanding Voltage: 100V AC
6. Operating temperature: -40° C ~ +85° C
7. Waterproof grade: IP-X7
8. Durability cycle: 10,000 cycles

Mechanical:

1. Connector Mate and Unmate Force
 - 1.1 Mate force: 5~20 N .
 - 1.2 Unmate force: 8~20 N

Material:

1. Housing: LCP
2. Contact: C18400
3. Shell: SUS
4. O-ring: Silicone

Finish:

1. Contact: Plated Gold in Mating Area ;
Tin Plated on Solder Balls ;
Nickel under plated overall
2. Shell: Nickel under Plated surface layer

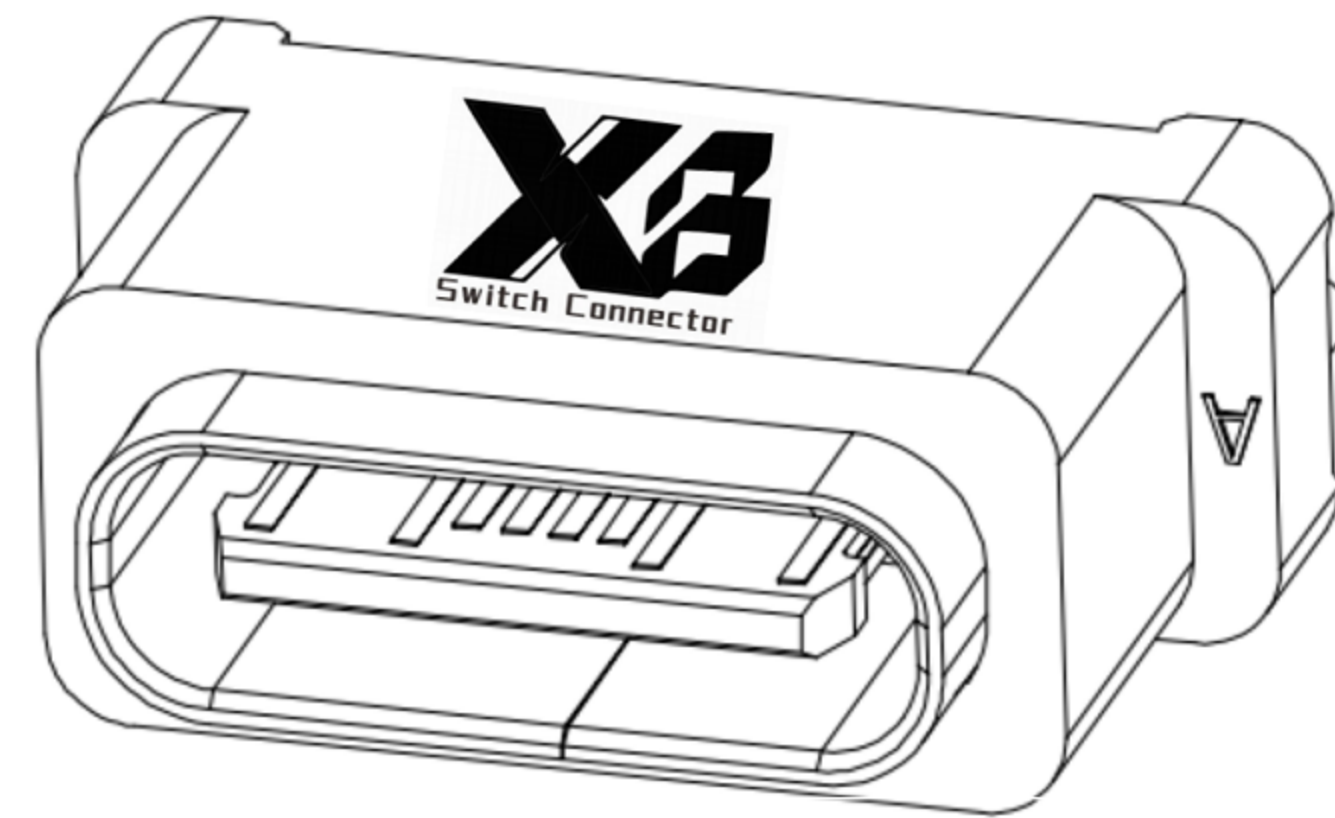

Structural design considerations:

When using the finished product, if there are foam, toothpaste, hand sanitizer, and dirty liquid in the facial cleanser, please design another layer of shell outside the mouth of TYPE-C to protect the gold finger on the surface of TYPE-C from being covered by dirt.

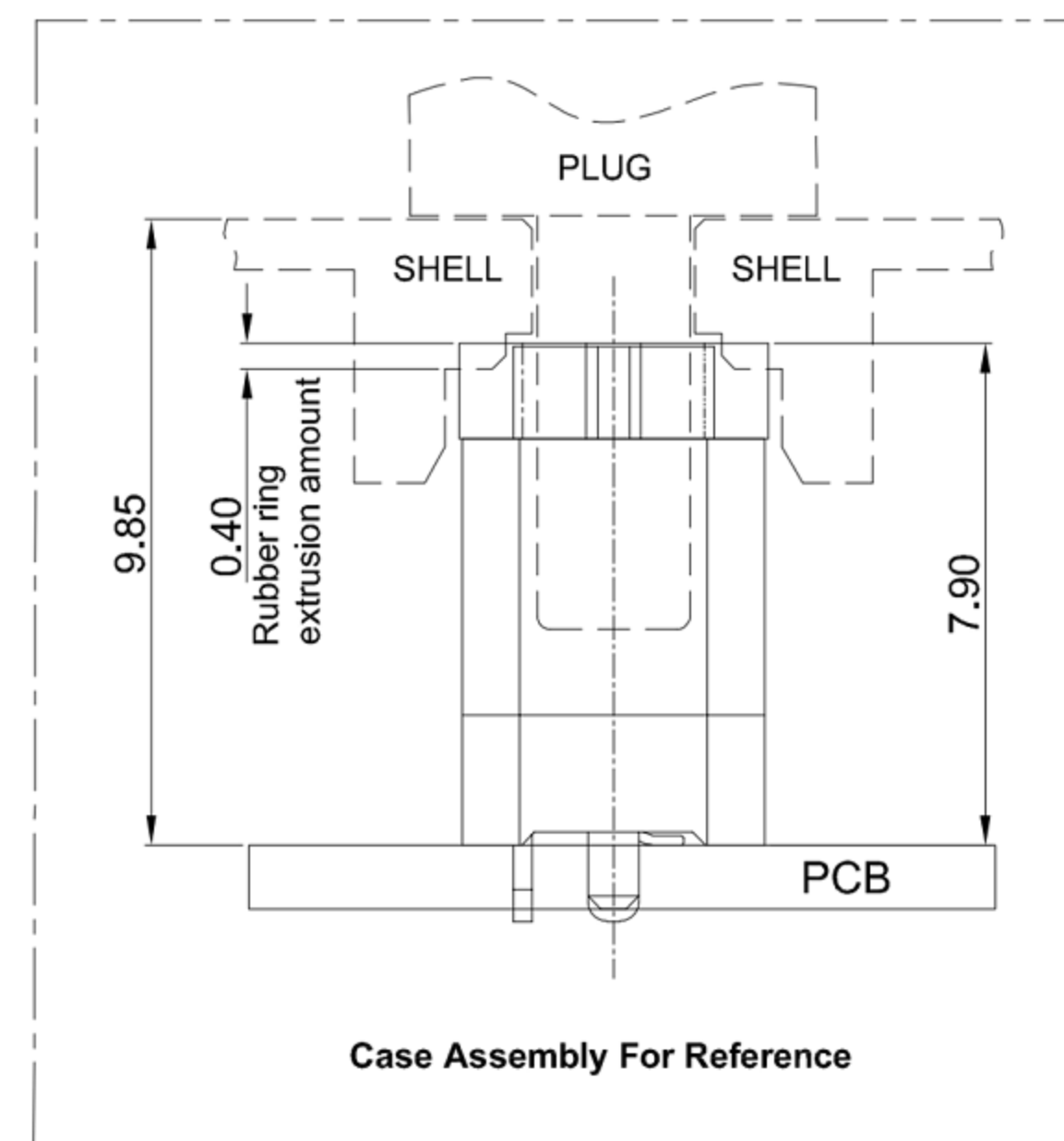

X3 东莞市溪榜电子有限公司
DONG GUAN XI BANG ELECTRONICS CO., LTD.

TOLERANCE UNLESS OTHERWISE STATED:
Up to 5 ±0.2
Above 5 ~ 15 ±0.3
Above 15 ~ 30 ±0.4
Above 30 ~ 50 ±0.5
Angle ±0.3°

3RD. ANGEL'S

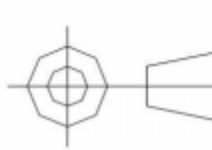

UNITS MM

DRAWN BY: Jack Lu
DATE: 03/10/22
CHECKED BY: Jacky Chen
DATE: 03/10/22
APPROVED BY: Tony Kao
DATE: 03/10/22

MAT'L		TITLE	CONNECTOR
FINISH		MODLE	Vertical Type-c 16P Female DIP H=7.85mm
SCALE	1 : 1	DWG NO.	XB-USB-C-1611-FS
SHEET NO.	1 of 1	PART NO.	

1	更新圖面	Jack	031022
ITEM NO.	DESCRIPTION	DRAWN	DATE

SIZE A4
VER R1