

Material:
 △ * Insulation: High Temperature Plastic
 UL 94V-0, Color Black

* Contact: Brass

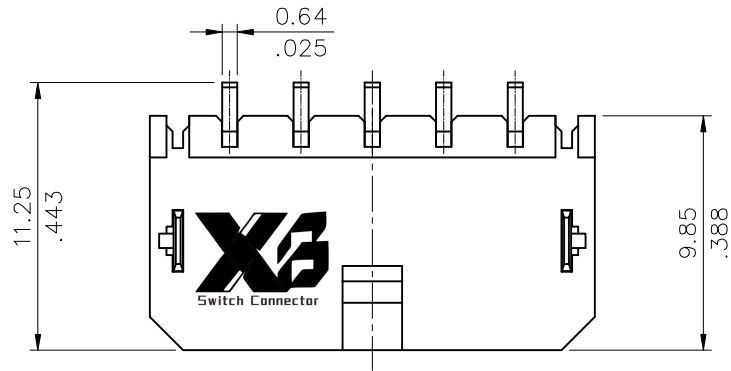

Ordering Code:

CP35 ** P * H S 0 - S - LF
 ① ② ③ ④ ⑤ ⑥ ⑦ ⑧ ⑨

- ① Series No.
- ② No. of Circuits: 02~12
- ③ Contact type: P= Plug
- ④ Contact plated:
 - 1= Matte Tin Plated over Nickel
 - △ A= Selective Gold Flash Plated over 1.27 μm(50 μ") Nickel
 - B= Selective 0.38 μm(15 μ") Gold Plated over 1.27 μm(50 μ") Nickel
 - C= Selective 0.76 μm(30 μ") Gold Plated over 1.27 μm(50 μ") Nickel
- ⑤ H= Right angle type
- ⑥ Mount type : S= SMT Type
- ⑦ 0= Standard (with Metal board lock)
- ⑧ S= Single Row Header
- ⑨ LF= Lead Free soldering process

CIRCUITS	DIM.A	DIM.B	DIM.C
2	3.00(.118)	9.65(.380)	7.3(.287)
3	6.00(.236)	12.65(.498)	10.3(.406)
4	9.00(.354)	15.65(.616)	13.3(.524)
5	12.00(.472)	18.65(.734)	16.3(.642)
6	15.00(.591)	21.65(.852)	19.3(.760)
7	18.00(.709)	24.65(.970)	22.3(.878)
8	21.00(.827)	27.65(1.089)	25.3(.996)
9	24.00(.945)	30.65(1.207)	28.3(1.114)
10	27.00(1.063)	33.65(1.325)	31.3(1.232)
11	30.00(1.181)	36.65(1.443)	34.3(1.350)
12	33.00(1.299)	39.65(1.561)	37.3(1.469)

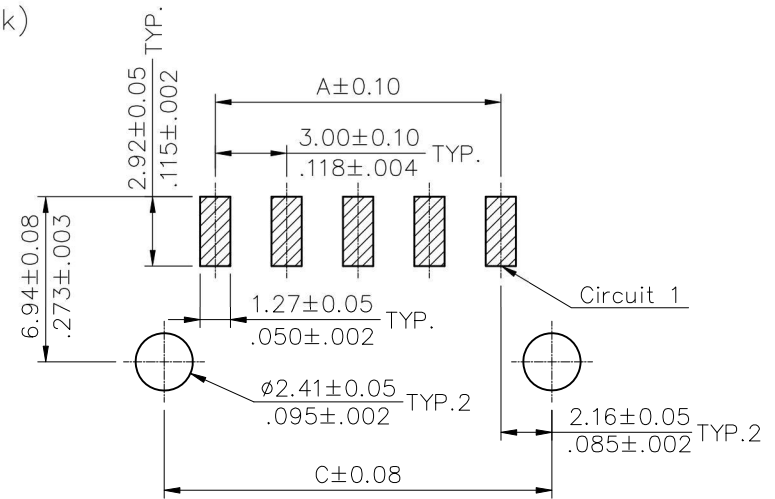
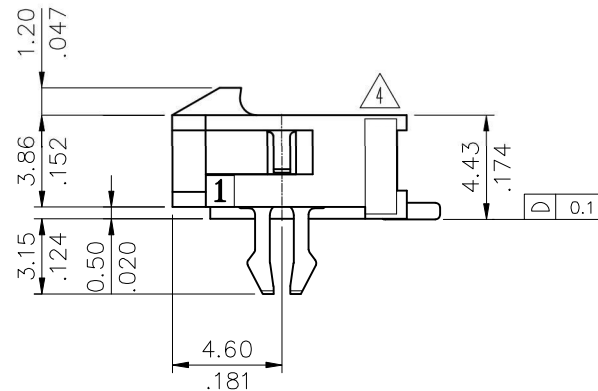
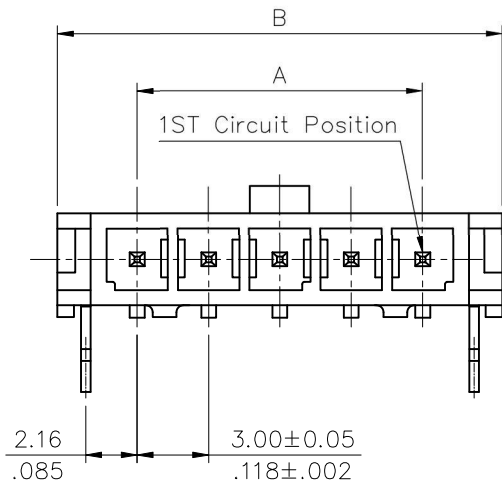

Recommended P.C. Board Layout

Lead Free Process

RoHS Compliant

SYM	NAME	DATE	REVISIONS	APPROVED BY:	DATE	UNIT: mm / inch	TITLE: 3.00mm PITCH RIGHT ANGLE SMT TYPE POWER CONN.										
△4	Eric	3/29-21'	ECRT121017/ECNT121085		DATE	UNIT: mm / inch	TITLE: 3.00mm PITCH RIGHT ANGLE SMT TYPE POWER CONN.										
△3	Yushu	4/15-19'	ECRB118091/ECNT119092	DRAWN BY: Eric	3/29-21'	TOLERANCE UNLESS OTHERWISE SPECIFIED .X ± 0.30/.012 X' ± 1' .XX ± 0.20/.008 .X' ± .XXX ± 0.10/.004 .XX' ±	MATERIAL: FINISH:										
△2	Eager	11/09-07'	ECN07463	ENGINEER: Sun	3/31-21'												
△1	Eager	10/04-07'	ECN07414	CHECKED BY: Eisley	4/1-21'												
				APPROVED BY: Eisley	4/1-21'												
<table border="1" style="width: 100%;"> <tr> <td colspan="2" rowspan="2"> 东莞市溪榜电子有限公司 DONG GUAN XI BANG ELECTRONICS CO., LTD. </td> <td>DRAWING NO.</td> <td>CP3569SD</td> <td>PART NO.</td> <td>CP35**P*HS0-S-LF</td> </tr> <tr> <td>SCALE</td> <td>3 / 1</td> <td>SHEET</td> <td>1 OF 1</td> </tr> </table>								东莞市溪榜电子有限公司 DONG GUAN XI BANG ELECTRONICS CO., LTD.		DRAWING NO.	CP3569SD	PART NO.	CP35**P*HS0-S-LF	SCALE	3 / 1	SHEET	1 OF 1
东莞市溪榜电子有限公司 DONG GUAN XI BANG ELECTRONICS CO., LTD.		DRAWING NO.	CP3569SD	PART NO.	CP35**P*HS0-S-LF												
		SCALE	3 / 1	SHEET	1 OF 1												