

Material:  
 ③ \* Insulation: High Temperature Plastic  
 UL 94V-0, Color Black  
 \* Contact: Brass

### Ordering Code:

CP35 \*\* P \* H S P - S - LF  
 ① ② ③ ④ ⑤ ⑥ ⑦ ⑧ ⑨

- ① Series No.
- ② No. of Circuits: 02~12
- ③ Contact type: P= Plug
- ④ Contact plated:  
 1= Matte Tin Plated over Nickel  
 ② A= Selective Gold Flash Plated over 1.27 $\mu$ m(50 $\mu$ "") Nickel  
 B= Selective 0.38 $\mu$ m(15 $\mu$ "") Gold Plated over 1.27 $\mu$ m(50 $\mu$ "") Nickel  
 C= Selective 0.76 $\mu$ m(30 $\mu$ "") Gold Plated over 1.27 $\mu$ m(50 $\mu$ "") Nickel
- ⑤ H= Right angle type
- ⑥ Mount type : S= SMT Type
- ⑦ P= With Plastic Board lock
- ⑧ S= Single Row Header
- ⑨ LF= Lead Free soldering process

CIRCUITS	DIM.A	DIM.B	DIM.C
2	3.00(.118)	9.65(.380)	NA
3	6.00(.236)	12.65(.498)	NA
4	9.00(.354)	15.65(.616)	4.7(.185)
5	12.00(.472)	18.65(.734)	7.7(.303)
6	15.00(.591)	21.65(.852)	10.7(.421)
7	18.00(.709)	24.65(.970)	13.7(.539)
8	21.00(.827)	27.65(1.089)	16.7(.657)
9	24.00(.945)	30.65(1.207)	19.7(.776)
10	27.00(1.063)	33.65(1.325)	22.7(.894)
11	30.00(1.181)	36.65(1.443)	25.7(1.012)
12	33.00(1.299)	39.65(1.561)	28.7(1.130)

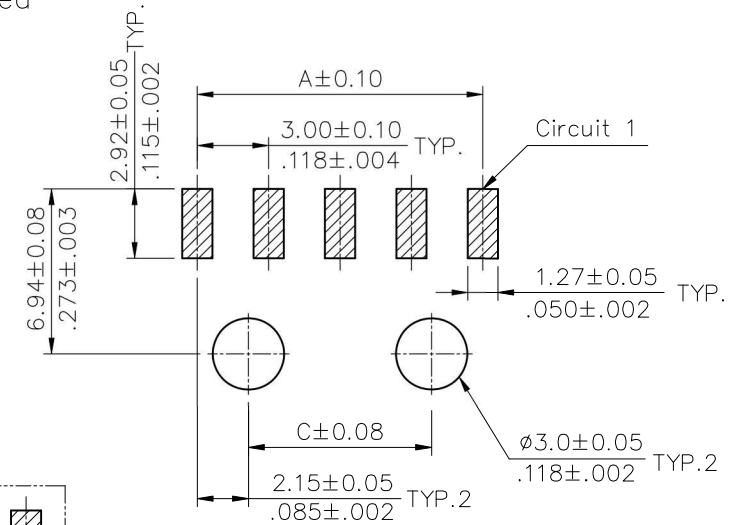
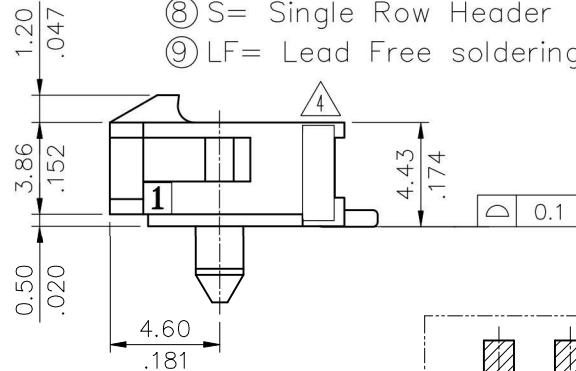
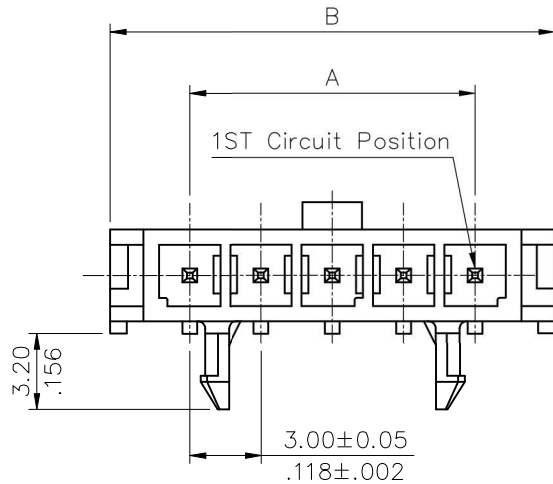
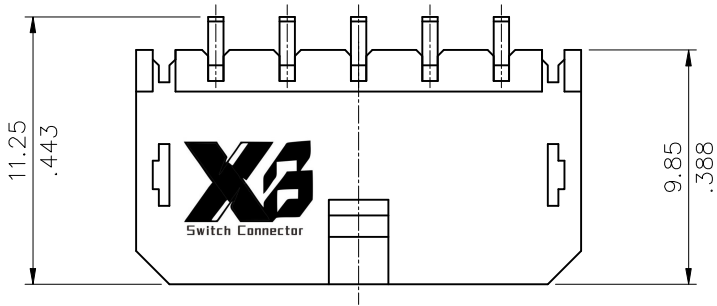

Recommended P.C. Board Layout

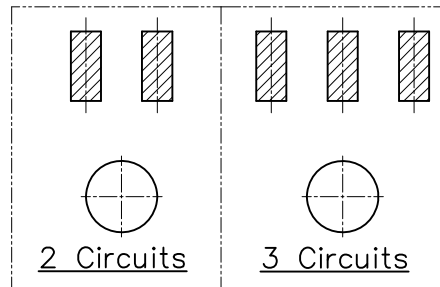

Lead Free Process  
 RoHS Compliant

④	Eric	3/29-21'	ECRT121017/ECNT121085		DATE	UNIT: mm / inch	TITLE: 3.00mm PITCH RIGHT ANGLE SMT TYPE POWER CONN.								
③	Yushu	4/15-19'	ECRB118091/ECNT119092	DRAWN BY: Eric	3/29-21'	TOLERANCE UNLESS OTHERWISE SPECIFIED .X ± 0.30/012 X.' ± 1' .XX ± 0.20/008 .X' ± .XXX ± 0.10/004 .XX' ±	MATERIAL:  FINISH:								
②	Eager	11/09-07'	ECN07463	ENGINEER: Sun	3/31-21'										
①	Eager	10/04-07'	ECN07414	CHECKED BY: Eisley	4/1-21'										
SYM	NAME	DATE	REVISIONS	APPROVED BY: Eisley	4/1-21'										
<table border="1" style="width: 100%;"> <tr> <td colspan="2">  东莞市溪榜电子有限公司            DONG GUAN XI BANG ELECTRONI CS CO., LTD.         </td> <td>DRAWING NO. CP3568SD</td> <td>PART NO. CP35**P*HSP-S-LF</td> </tr> <tr> <td>SCALE</td> <td>3 / 1</td> <td>SHEET</td> <td>1 OF 1</td> </tr> </table>								东莞市溪榜电子有限公司 DONG GUAN XI BANG ELECTRONI CS CO., LTD.		DRAWING NO. CP3568SD	PART NO. CP35**P*HSP-S-LF	SCALE	3 / 1	SHEET	1 OF 1
东莞市溪榜电子有限公司 DONG GUAN XI BANG ELECTRONI CS CO., LTD.		DRAWING NO. CP3568SD	PART NO. CP35**P*HSP-S-LF												
SCALE	3 / 1	SHEET	1 OF 1												