

Material :

- * Insulation:
Nylon66 30% G.F. UL 94V-0(Nature)
- * S.Q PIN: Brass

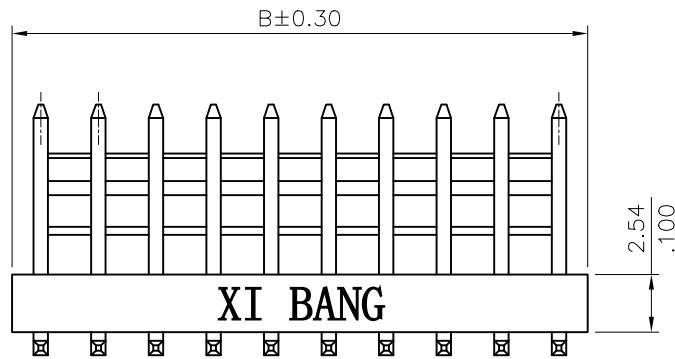

DIM.A = 2.54 x (NO. OF CIRCUIT-1)
 DIM.B = DIM.A + 2.54
 *Available in 2~28 Circuits

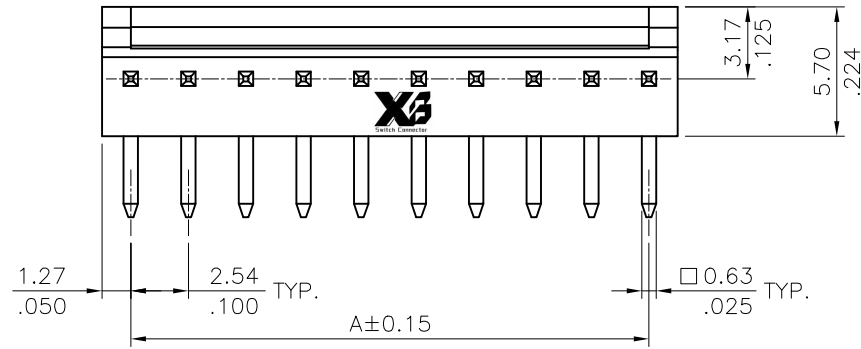
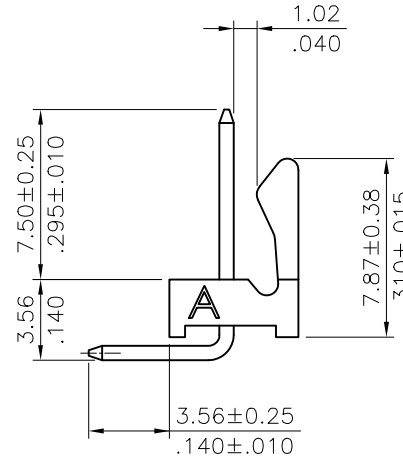

Ordering Code:

CI88 ** P * H 00 -NH
 ① ② ③ ④ ⑤ ⑥ ⑦

- ① Series No.
- ② No. of contacts
- ③ P= DIP Header
- ④ Plating code:
1= Tin over Nickel
2= Gold flash plated over 1.27um(50u") Nickel
- ⑤ Contact Type: H= Right angle
- ⑥ Option: 00= Standard
- ⑦ -NH= For Lead Free IR Processes and Halogen-Free

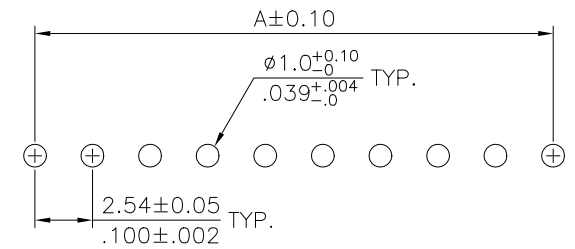

Recommended P.C. Board Layout

Halogen-Free

Lead Free Process

RoHS Compliant

④					DATE	UNIT: mm / inch	TITLE: CI88 Series 2.54mm S/T Header	东莞市溪榜电子有限公司 DONG GUAN XI BANG ELECTRONI CS CO., LTD.
③				DRAWN BY: Hank	9/25-15'	TOLERANCE UNLESS OTHERWISE SPECIFIED	MATERIAL:	
②				ENGINEER: Easley	9/30-15'	.X ± 0.30/.012 X' ± 1'	FINISH:	
①				CHECKED BY: Easley	9/30-15'	.XX ± 0.20/.008 X' ±		
SYM	NAME	DATE	REVISIONS	APPROVED BY: David	9/30-15'	.XX ± 0.10/.004 X' ±		DRAWING NO. CI8802SA PART NO. CI88**P*H00-NH SCALE 3 / 1 SHEET 1 OF 1