

Notes :

- * Base: High Temperature Plastic UL 94V-0 Color Black (Halogen-Free)
- * Contact: Copper Alloy
- * Shell: Stainless Steel
solder area gold flash over nickel
- * For Lead-Free IR Reflow process

Ordering Code:

CI99 ** M 2 H R E -NH
 ① ② ③ ④ ⑤ ⑥ ⑦ ⑧

- ① Series No.
- ② No. of Circuits: 06, 07, 08, 09 Pin
- ③ M= SMT Type
- ④ Plating: 2= 0.03um(1.2u") Min. Gold Flash Plating on Contact area and Solder tails, 1.27um(50u") Nickel Underplating over all
- ⑤ Type: H= Side entry
- ⑥ Packing Options: R= Tape & Reel packing
- ⑦ Option: E= E type
- ⑧ Other option:
-NH= For Lead Free IR Processes and Halogen-Free

| Circuits | Dimension | | | |
|----------|-------------|------------|------------|------------|
| | A | B | C | D |
| 06 | 10.00(.394) | 17.0(.669) | 12.2(.480) | 15.7(.618) |
| 07 | 12.00(.472) | 19.0(.748) | 14.2(.559) | 17.7(.697) |
| 08 | 14.00(.551) | 21.0(.827) | 16.2(.638) | 19.7(.776) |
| 09 | 16.00(.630) | 23.0(.906) | 18.2(.717) | 21.7(.854) |

Halogen-Free Lead Free Process RoHS Compliant

| | | | | | | | | |
|-----|-------|-----------|-----------------------|--------------|----------------|-----------------|-------------------------|---|
| ④ | | | | | DATE | UNIT: mm / inch | TITLE: 2.00MM(.079") | 东莞市溪榜电子有限公司 DONG GUAN XI BANG ELECTRONICS CO., LTD. |
| ③ | | | | | DRAWN BY: Jack | 12/22-23' | WIRE TO BOARD CONNECTOR | |
| ② | Jack | 12/22-23' | ECNT123179/ECRB123029 | ENGINEER: | Clark | 12/22-23' | MATERIAL: | DRAWING NO. CI9911SB PART NO. CI99**M2HRE-NH |
| ① | Clark | 06/29-16 | ECNT116140 | CHECKED BY: | Eisley | 12/22-23' | CUSTOMER: | |
| SYM | NAME | DATE | REVISIONS | APPROVED BY: | Eisley | 12/22-23' | | SCALE 4 / 1 SHEET 1 OF 1 |

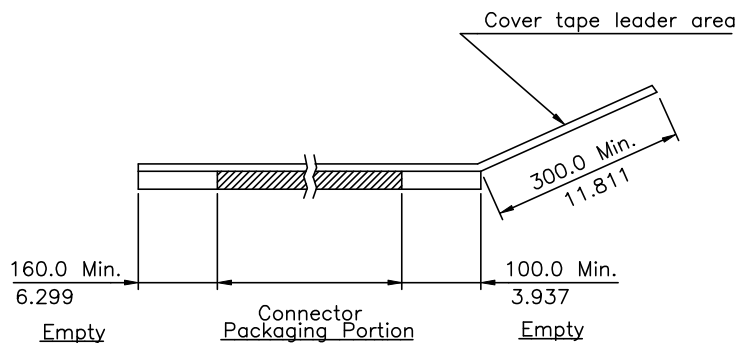
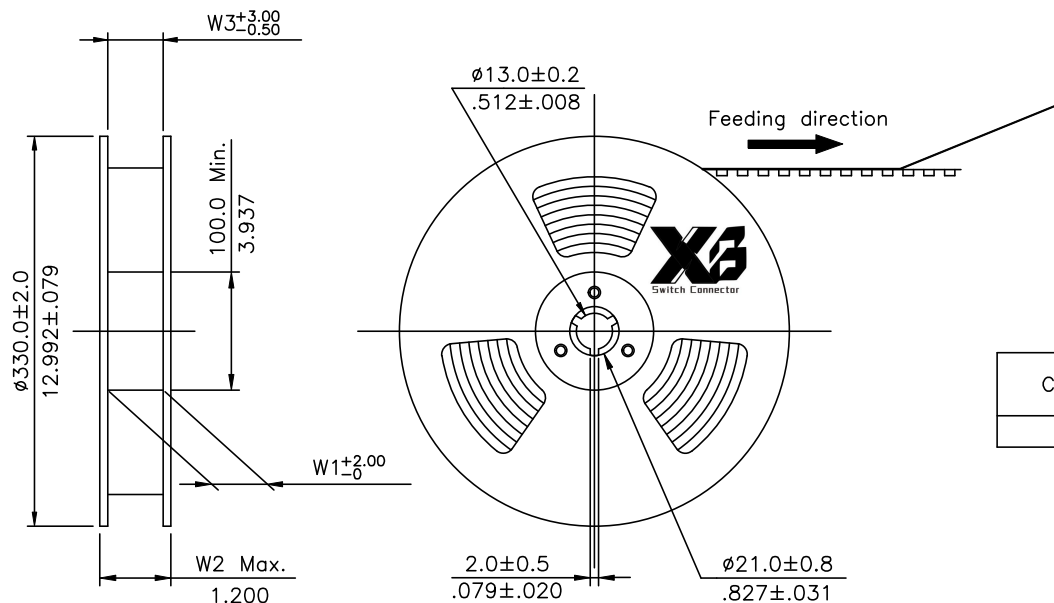

NOTE :

- △2 * Reel Material : HIPS
- * Carrier Material : Black, Conductive Polystyrene Alloy
- * Cover Tape Material : Polyester
- * Cover Tape Peel Strength : 0.1N – 1.3N
- * Carrier camber is within 1mm in 100mm
- △2 * All dimensions meet EIA-481 requirements.
- * Quantity : 1400 PCS/Reel

| Circuits | Dimension | | | | | Packing (Reel/Carton) |
|----------|-------------|--------------|-------------|-------------|-------------|--------------------------|
| | W | F | W1 | W2 | W3 | |
| 09 | 44.0(1.732) | 40.40(1.596) | 44.5(1.752) | 50.5(1.988) | 44.5(1.752) | 5 |

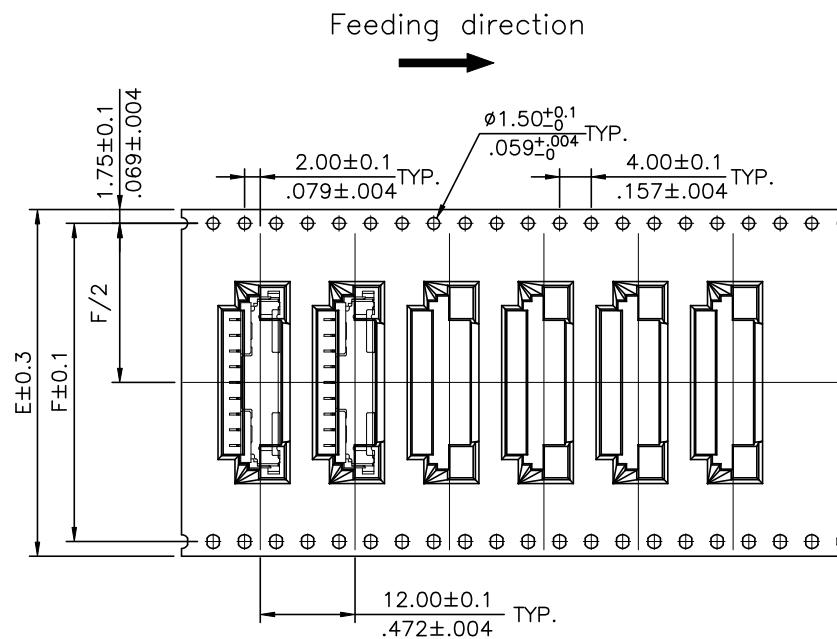

WIDTH : 44 mm Carrier

RoHS Compliant

| SYM | NAME | DATE | REVISIONS | APPROVED BY: | Eisley | 12/22-23' | UNIT: mm / inch | TITLE: 2.00MM(.079") WIRE TO BOARD CONNECTOR |
|-----|-------|-----------|-----------------------|--------------|--------|-----------|---|---|
| 4 | | | | | | | TOLERANCE UNLESS OTHERWISE SPECIFIED | MATERIAL: |
| 3 | | | | | | | | |
| 2 | Jack | 12/22-23' | ECNT123179/ECRB123029 | ENGINEER: | Clark | 12/22-23' | .X ± 0.25/.010 | .X* ± * |
| 1 | Clark | 06/29-16 | ECNT116140 | CHECKED BY: | Eisley | 12/22-23' | .XX ± 0.15/.006 | .X* ± |
| | | | | APPROVED BY: | Eisley | 12/22-23' | .XXX ± 0.08/.003 | .XX* ± |

XB 东莞市溪榜电子有限公司
Switch Connector DONG GUAN XI BANG ELECTRONICS CO., LTD.

| | | | |
|-------------|----------|----------|----------------|
| DRAWING NO. | CI9911SB | PART NO. | CI99**M2HRE-NH |
| SCALE | | SHEET | 2 OF 2 |