

NOTE:

Material :

- * Base : PA6T With 30% GF., UL 94V-0 Color Nature
- * Contact : Brass
- * Fixed tab : Brass
- * Tab Plating : 100u" Min. Matte Tin Plated over 50u" Nickel
- * For Lead Free IR Reflow Process

ORDERING CODE

CI42 ** M 2 H R * -NH
 ① ② ③ ④ ⑤ ⑥ ⑦ ⑧

- ① Series No.
- ② Contact: 02 to 12
- ③ M= SMT TYPE HEADER
- ④ Plating :
 1= 3.05μm(120μ") Min. Matte Tin Plated over 1.27um(50μ") Nickel
 2= Gold flash over 1.27μm(50μ") Nickel
- ⑤ Type : H= Side entry
- ⑥ Packing option:
 R= Tape & Reel Packing
- ⑦ Other option:
 D= Middle mount type, Without Mylar
 A= Middle mount type, With Mylar
- ⑧ -NH= For Lead Free IR Processes and Halogen-Free

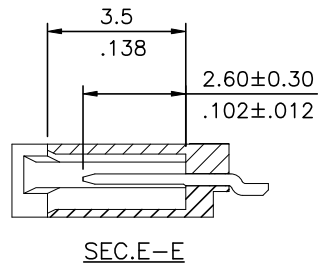
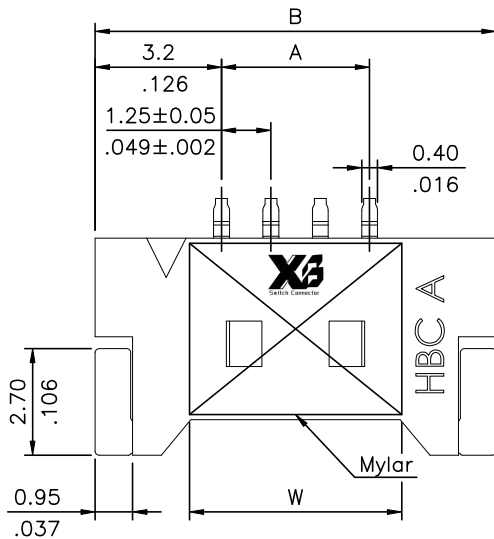

Circuits	A	B	△ C
2	1.25(.049)	7.65(.301)	2.80(.110)
3	2.50(.098)	8.90(.350)	4.05(.159)
4	3.75(.148)	10.15(.400)	5.30(.209)
5	5.00(.197)	11.40(.449)	6.55(.258)
6	6.25(.246)	12.65(.498)	7.80(.307)
7	7.50(.295)	13.90(.547)	9.05(.356)
8	8.75(.344)	15.15(.596)	10.30(.406)
9	10.00(.394)	16.40(.646)	11.55(.455)
10	11.25(.443)	17.65(.695)	12.80(.504)
11	12.50(.492)	18.90(.744)	14.05(.553)
12	13.75(.541)	20.15(.793)	15.30(.602)

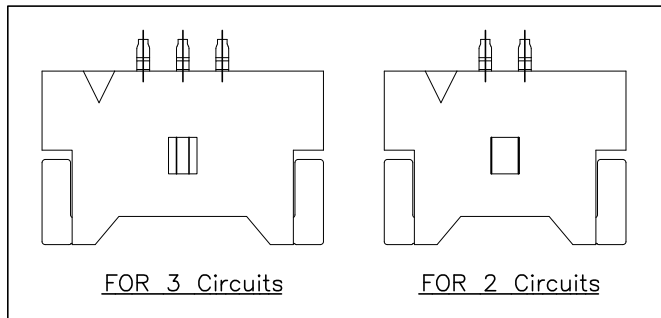
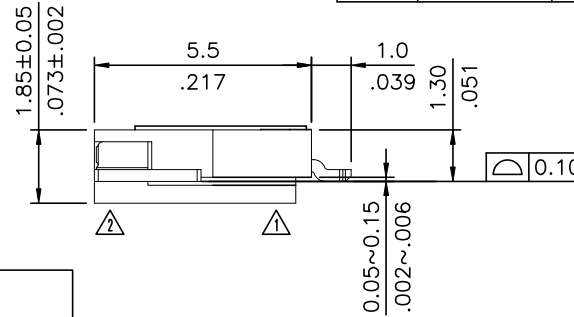
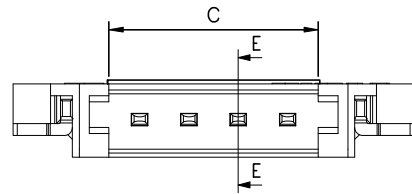

Circuits	W
2~3	5.0 (.197)
4~6	6.0 (.236)
7~12	10.0 (.394)

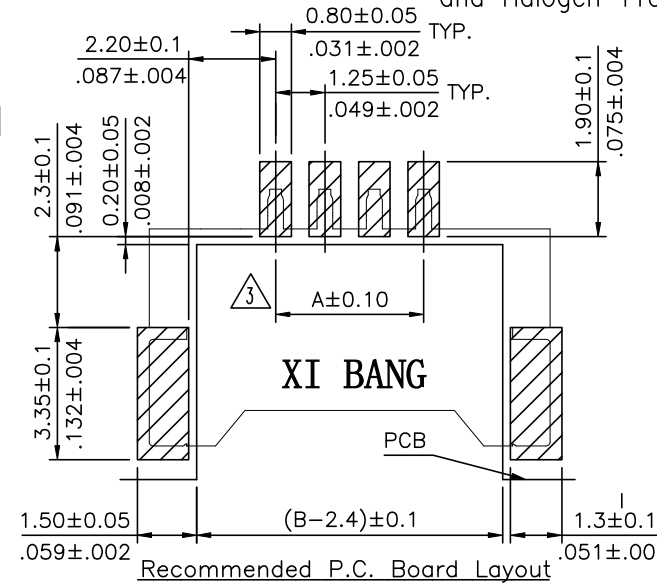

Halogen-Free
 Lead Free Process
 RoHS Compliant

REV	SYM	NAME	DATE	REVISIONS	APPROVED BY:	DATE
4	Jack	12/27-23'	ECNT123179/ECRB123029			
3	Karen	6/27-22'	ECNT122107		DRAWN BY: Jack	12/27-23'
2	Sun	4/28-16'	ECRT116015/ECNT116085		ENGINEER: Sun	12/27-23'
1	Sun	5/18-15'	ECRT115028/ECNT115114		CHECKED BY: Eisley	12/27-23'
					APPROVED BY: Eisley	12/27-23'

TITLE: 1.25mm Side entry SMT Type Connector
 MATERIAL:
 FINISH:

东莞市溪榜电子有限公司 DONG GUAN XI BANG ELECTRONI CS CO., LTD.			
DRAWING NO.	CI4216SE	PART NO.	CI42**M*HR*-NH
SCALE	5 / 1	SHEET	1 OF 2

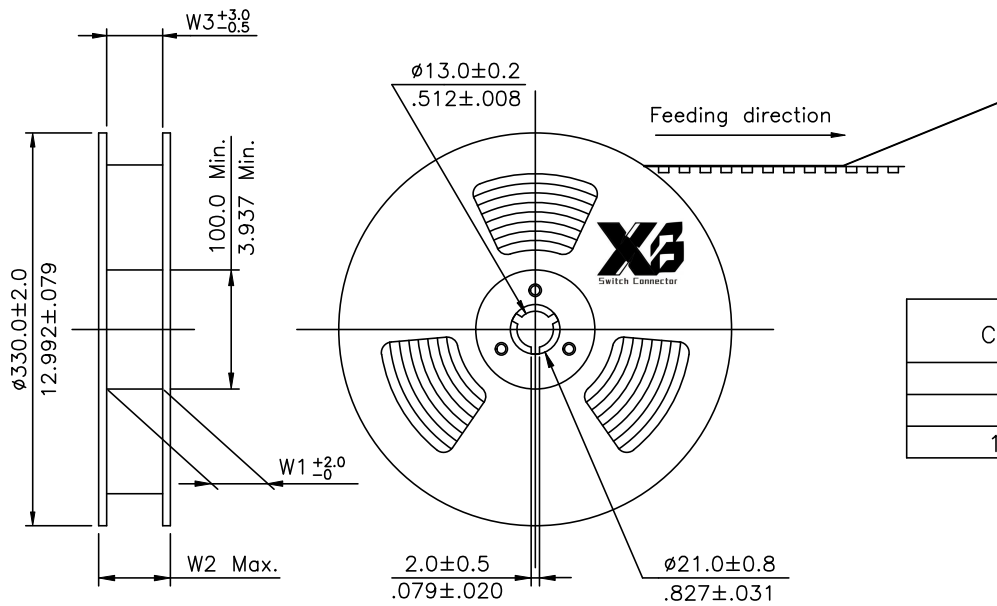

4 NOTES:

1. Reel Material : HIPS
2. 10 sprocket hole pitch cumulative tolerance ± 0.20
3. Carrier camber is within 1 mm in 250 mm.
4. Material :Transparent ps.
5. All dimensions meet EIA-481 requirements.
6. Thickness : 0.35 ± 0.05 mm.
7. Quantity : 2000 pcs.

Circuits	Dimension					Packing (Reel/Carton)
	E	F	W1	W2	W3	
2~3	16.0(.630)	—	16.5(.650)	22.5(.885)	16.5(.650)	11
4~9	24.0(.945)	—	24.5(.965)	30.5(1.200)	24.5(.965)	9
10~12	32.0(1.260)	28.40(1.118)	32.5(1.280)	38.5(1.516)	32.5(1.280)	7

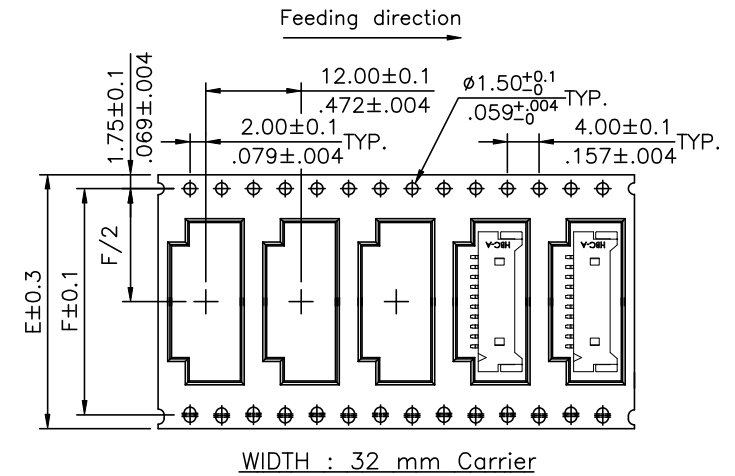
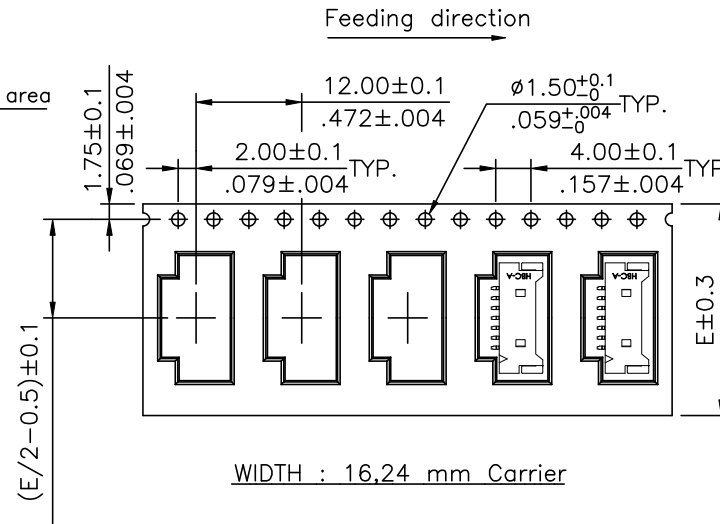
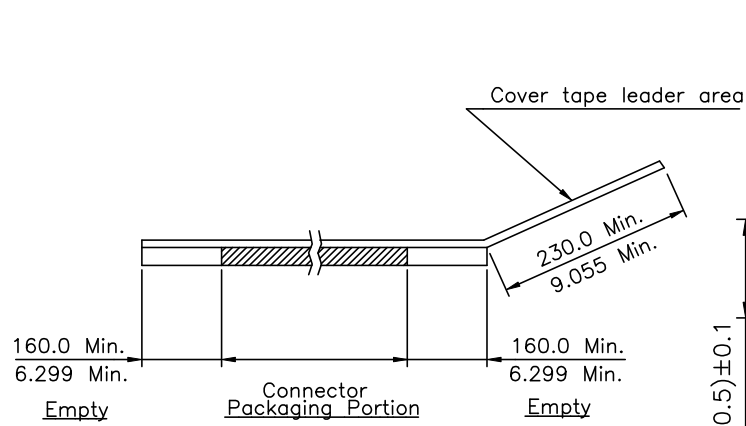

RoHS Compliant

SYM	NAME	DATE	REVISIONS	APPROVED BY:	Eisley	12/27-23'
4	Jack	12/27-23'	ECNT123179/ECRB123029	DATE	UNIT: mm / inch	TITLE: 1.25mm Side entry SMT Type Connector
3	Karen	6/27-22'	ECNT122107	DRAWN BY: Jack	TOLERANCE UNLESS OTHERWISE SPECIFIED	
2	Sun	4/28-16'	ECRT116015/ECNT116085	ENGINEER: Sun	12/27-23'	MATERIAL:
1	Sun	5/18-15'	ECRT115028/ECNT115114	CHECKED BY: Eisley	12/27-23'	
SYM	NAME	DATE	REVISIONS	APPROVED BY:	Eisley	12/27-23'

东莞市溪榜电子有限公司
 DONG GUAN XI BANG ELECTRONICS CO., LTD.

DRAWING NO.	CI4216SE	PART NO.	CI42**M*HR*-NH
SCALE		SHEET	2 OF 2