

ORDERING CODE

C108 ** P * H R * -NH
 ① ② ③ ④ ⑤ ⑥ ⑦ ⑧

- ① Series No.
- ② Contact: 03 to 10
- ③ P= DIP Type
- ④ Plating :
 1= 2.54μm(100u") Min. Matte Tin Plating on Contact area and Solderails, 1.27um(50u") Nickel Underplating over all
 2= 0.03um(1.2u") Min. Gold Flash Plating on Contact area and Solderails, 1.27um(50u") Nickel Underplating over all
- ⑤ Contact type: H= Side entry
- ⑥ Packing option:
 R= Tape & Reel Packing
- ⑦ Other option:
 0= DIM.E=0.9 DIM.F=1.0, 1= DIM.E=0.9 DIM.F=1.2
 2= DIM.E=1.3 DIM.F=1.0, 4= DIM.E=1.3 DIM.F=1.2
- ⑧ -NH= For Lead Free IR Processes and Halogen-Free

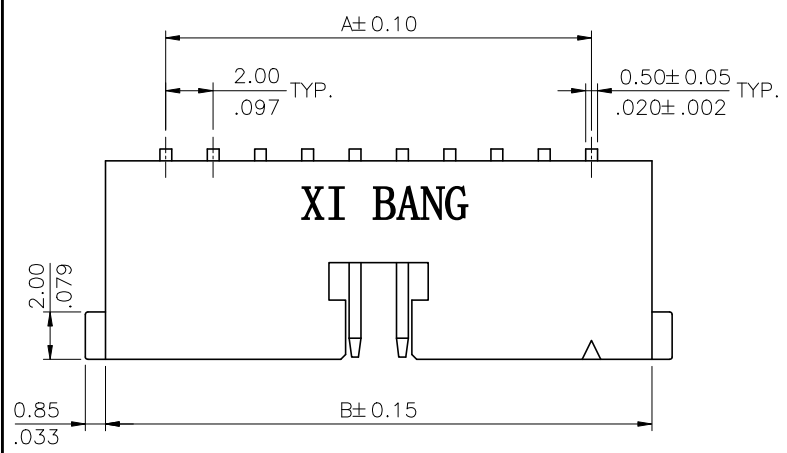

Note:

- * Insulator: Halogen Free Plastic
UL 94V-0 Color Black
- * Contact: Brass
- * For Lead Free IR Reflow process

DIM. A = 2.00 × NO. OF SPACES
 DIM. B = DIM. A + 5.1
 DIM. C = DIM. A + 2.6
 DIM. D = DIM. A + 0.4

* AVAILABLE IN 3 THROUGH 10

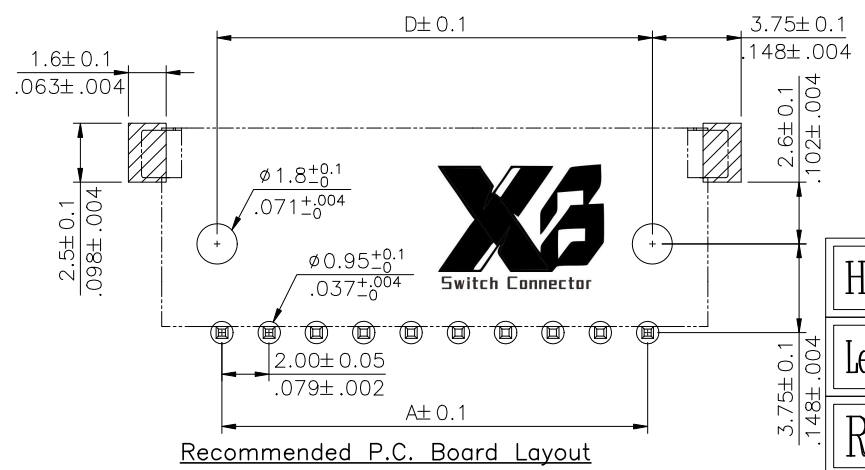
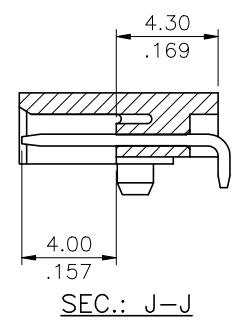
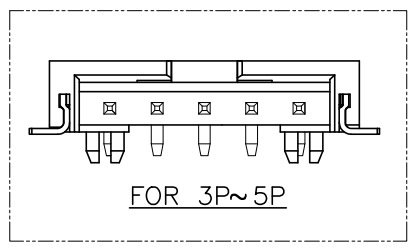
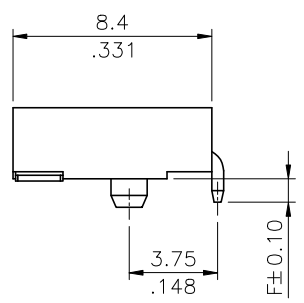
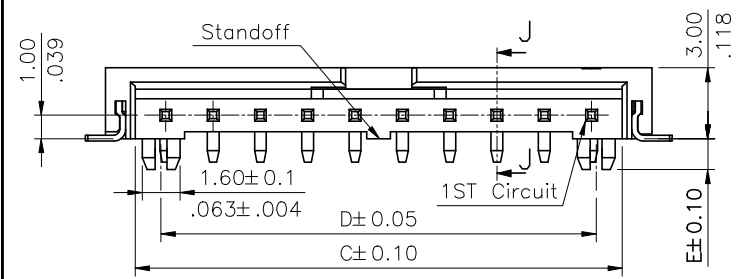

Halogen-Free

Lead Free Process

RoHS Compliant

④					DATE	UNIT: mm / inch	TITLE: 2.0mm Pitch WTB DIP R/A TYPE	 东莞市溪榜电子有限公司 DONG GUAN XI BANG ELECTRONI CS CO., LTD.
③				DRAWN BY: Hank	3/3-14'	TOLERANCE UNLESS OTHERWISE SPECIFIED		
②				ENGINEER: Eisley	3/3-14'	.X ± 0.30/.012	X' ± 1'	
①				CHECKED BY: David	3/3-14'	.XX ± 0.20/.008	.X' ±	
SYM	NAME	DATE	REVISIONS	APPROVED BY: David	3/3-14'	.XXX ± 0.10/.004	.XX' ±	
DRAWING NO. C1080BSA								PART NO. C108**P*HR*-NH
SCALE 3 / 1								SHEET 1 OF 2

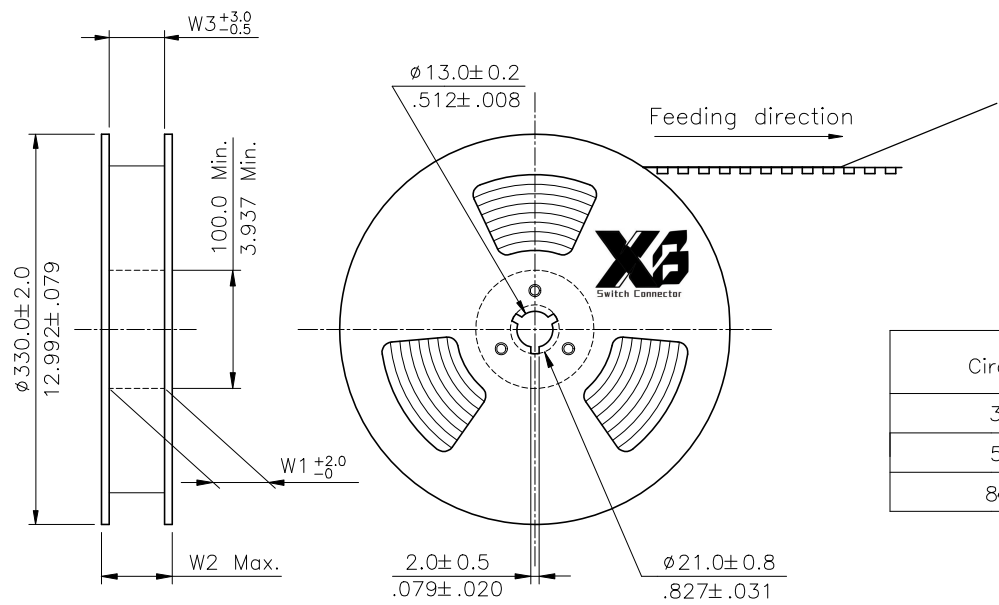

NOTE :

- * Reel Material : Corrugated Paper
- * Carrier Material : Black, Polystyrene alloy
- * Cover Tape Material : Polyester
- * Cover Tape Peel Strength : 0.1N - 1.3N
- * Carrier camber is within 1mm in 100mm
- * All dimensions meet EIA-481-2 & EIA-481-3 requirements.
- * Quantity : 800 PCS/Reel

Circuits	Dimension					Packing (Reel/Caton)
	E	F	W1	W2	W3	
3~4	24.0(.945)	—	24.5(.965)	30.5(1.200)	24.5(.965)	9
5~7	32.0(1.260)	28.4(1.118)	32.5(1.280)	38.5(1.516)	32.5(1.280)	7
8~10	44.0(1.732)	40.4(1.596)	44.5(1.752)	50.5(1.988)	44.5(1.752)	5

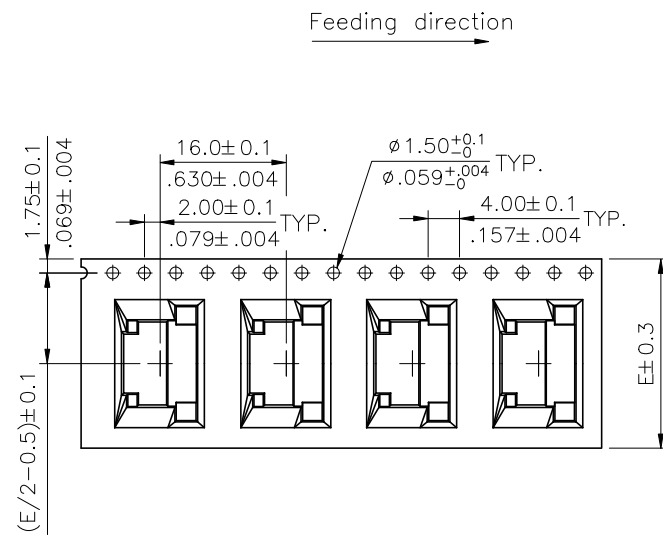
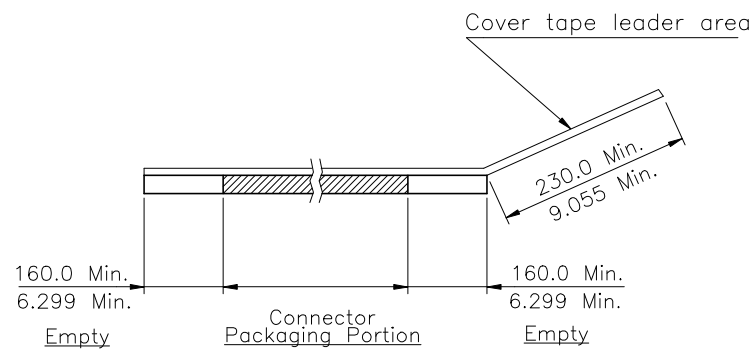

WIDTH : 24 mm Carrier

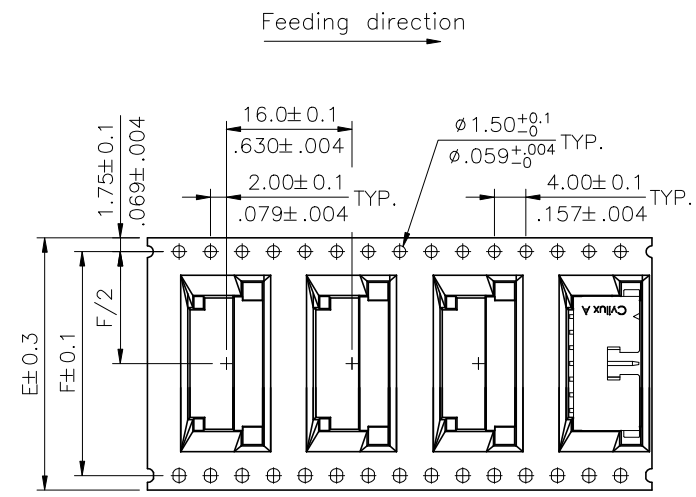

WIDTH : 32.44 mm Carrier

RoHS Compliant

4				DATE	UNIT: mm / inch	TITLE: 2.0mm Pitch WTB DIP R/A TYPE
3				DRAWN BY: Hank	TOLERANCE UNLESS OTHERWISE SPECIFIED	MATERIAL:
2				ENGINEER: Eisley		
1				CHECKED BY: David	.X ±	X' ± 1'
				APPROVED BY: David	.XX ±	.X ±
					.XXX ±	.XX ±
SYM	NAME	DATE	REVISIONS	APPROVED BY:		FINISH:

XB 东莞市溪榜电子有限公司
Switch Connector DONG GUAN XI BANG ELECTRONICS CO., LTD.

DRAWING NO.	CI0808SA	PART NO.	CI08**P*HR*-NH
SCALE		SHEET	2 OF 2