

8PIN

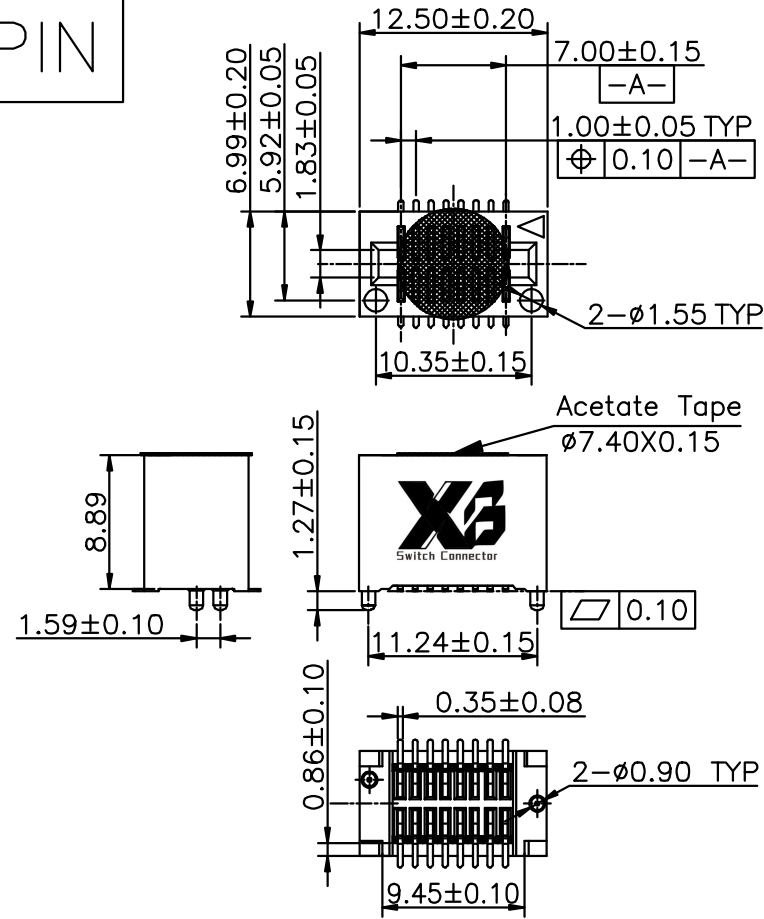

Specifications
 Current Rating:1.0Amp
 Insulation Resistance:1000MΩMin.
 Dielectric Withstanding Voltage:300VAC
 Contact Resistance:20mΩMax.
 Operating Temperature:-40°C to +105°C
 Materials
 Contact Material:Phosphor Bronze
 Insulator Material:High Temperature Thermoplastic, UL 94V-0 LCP or the equivalent material
 All materials must meet XI BANG hazardous substances control standards.

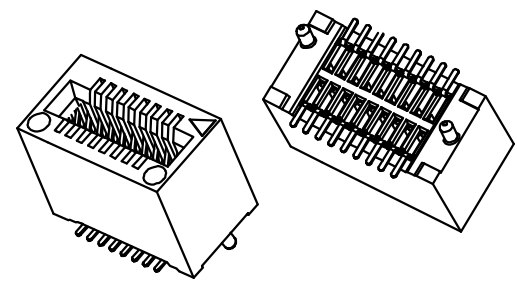
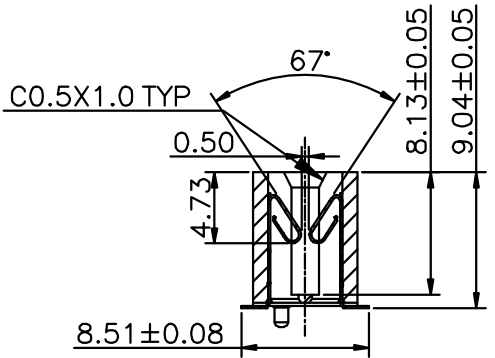

Recommended P.C.Board Layout
 (Tolerance:±0.05)

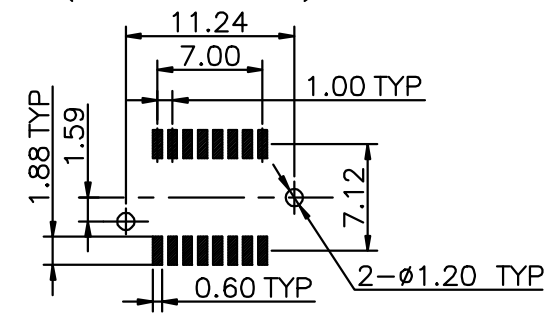

Ordering Information

C SCC215 - 08 XX B 001 C 1 A X

No. of Pins per Row
08

Standard Plating
02=Gold Flash
Selective Plating
01=Tin
05=Gold Flash/Tin
45=10u" Gold on conatct point ,
Matte Tin on tail(Matte Tin 80~160u")

Color
1=Black

Standard Packing
C=Tube
Selective Packing
A=Box
G=Acetate Tape+Tube
H=Acetate Tape+Tape&Reel
D=Tape&Reel

XB 东莞市溪榜电子有限公司
 DONG GUAN XI BANG ELECTRONICS CO., LTD.

GENERAL TOLERANCE	
X:±5.0'	X.±0.30
.X'±3.0'	.X±0.25
.XX'±2.0'	.XX±0.15
.XXX'±1.0'	.XXX±0.10

DESIGNED:	DATE:
CHECKED:	DATE:
CO SIGNED:	DATE:
APPROVED:	DATE:

DWG. NO. XB-CSCC-215
PART NO.

TITLE. 1.00 FEMALE HEADER DAUL ROWS SMT TYPE CONNECTOR

REV. 01	UNIT. mm	SCALE. 2:1	PAGE. 1/1	
------------	-------------	---------------	--------------	--

20PIN

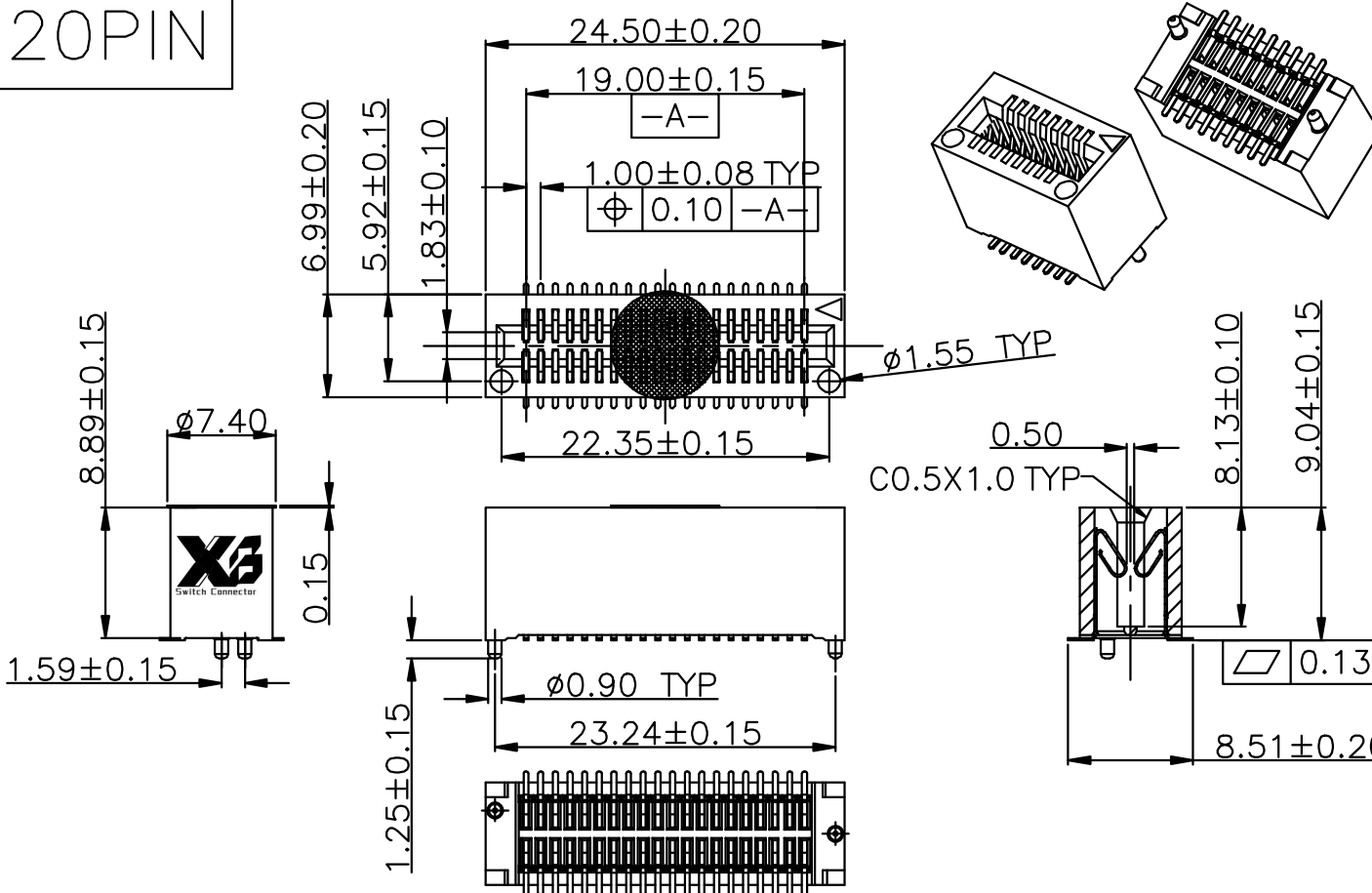

Specifications
 Current Rating:1.0Amp
 Insulation Resistance:1000MΩMin.
 Dielectric Withstanding Voltage:300VAC
 Contact Resistance:20mΩMax.
 Operating Temperature:-40°C to +105°C
 Materials
 Contact Material:Phosphor Bronze
 Insulator Material:High Temperature Thermoplastic, UL 94V-0 LCP or the equivalent material
 All materials must meet XI BANG hazardous substances control standards.

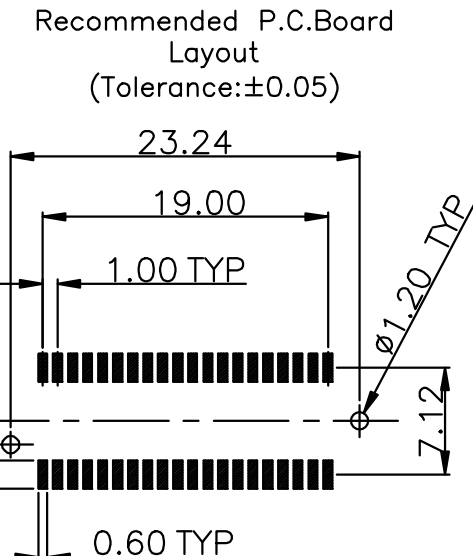

Ordering Information

C SCC215 - 20 XX B 001 C 1 A X

No. of Pins per Row 20
 Standard Plating 02=Gold Flash
 Selective Plating 01=Tin 05=Gold Flash/Tin 45=10u" Gold on conatct point , Matte Tin on tail(Matte Tin 80~160u")
 Color 1=Black
 Standard Packing C=Tube Selective Packing A=Box G=Acetate Tape+Tube H=Acetate Tape+Tape&Reel D=Tape&Reel

XB 东莞市溪榜电子有限公司
 DONG GUAN XI BANG ELECTRONI CS CO., LTD.

GENERAL TOLERANCE	
X:±5.0'	X.±0.30
.X'±3.0'	.X±0.25
.XX'±2.0'	.XX±0.15
.XXX'±1.0'	.XXX±0.10

DESIGNED:	DATE:
CHECKED:	DATE:
CO SIGNED:	DATE:
APPROVED:	DATE:

DWG. NO. XB-CSCC-215
PART NO.

TITLE.
 1.00 FEMALE HEADER DAUL ROWS SMT TYPE CONNECTOR

REV.	UNIT.	SCALE.	PAGE.
01	mm	2:1	1/1

30PIN

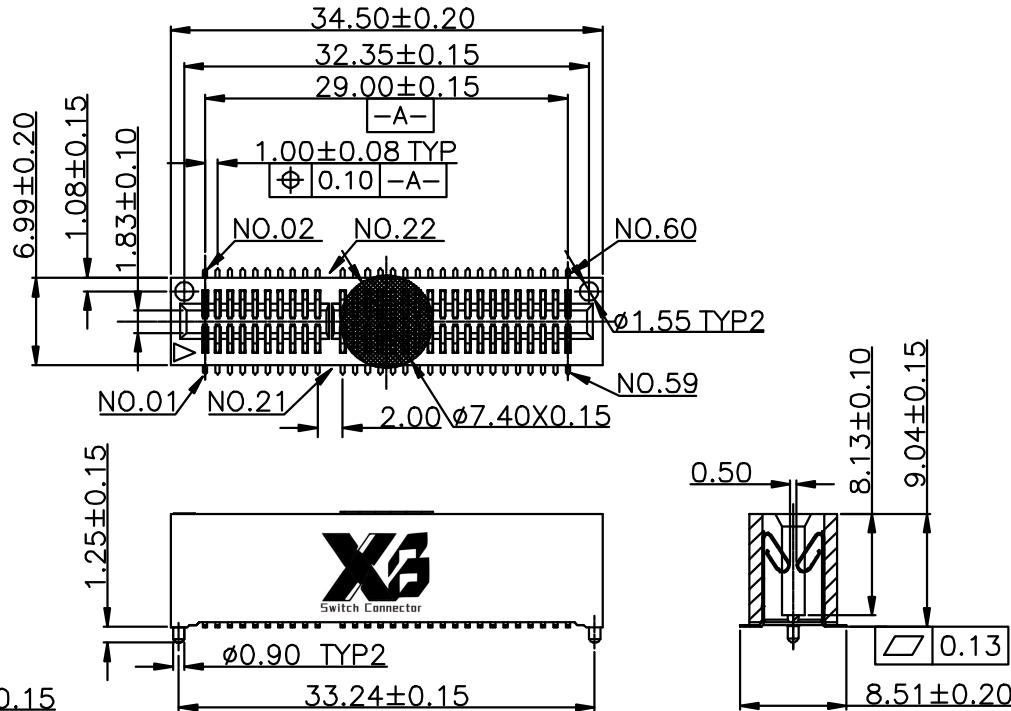

Specifications
 Current Rating:1.0Amp
 Insulation Resistance:1000MΩMin.
 Dielectric Withstanding Voltage:300VAC
 Contact Resistance:20mΩMax.
 Operating Temperature:-40°C to +105°C
 Materials
 Contact Material:Phosphor Bronze
 Insulator Material:High Temperature Thermoplastic, UL 94V-0 LCP or the equivalent material
 All materials must meet XI BANG hazardous substances control standards.

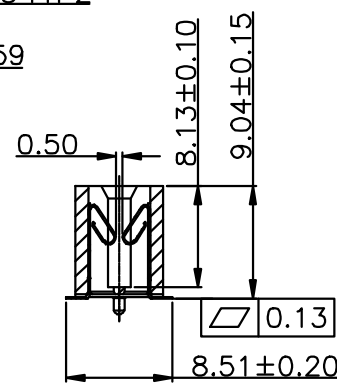

Recommended P.C.Board Layout
 (Tolerance:±0.05)

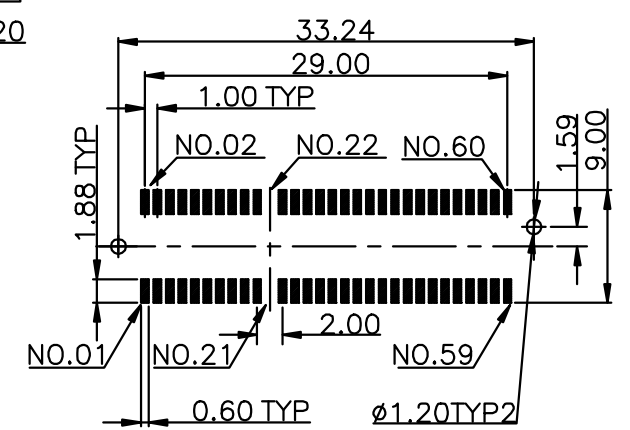

Ordering Information

C SCC215 - 30 XX B 001 C X S X

No. of Pins per Row: 30
 Standard Plating: 01=Tin
 Selective Plating: 45=10u"Au/80u"~160u"Matte Tin
 Color: 1=Black
 Standard Packing: C=Tube
 Selective Packing: G=acetate tape +Tube, H=acetate tape +Tape&Reel

XB 东莞市溪榜电子有限公司
 DONG GUAN XI BANG ELECTRONICS CO., LTD.

GENERAL TOLERANCE	
X: ±3.0'	X: ±0.25
.X: ±2.0'	.X: ±0.20
.XX: ±1.0'	.XX: ±0.13
.XXX: ±0.5'	.XXX: ±0.08

DESIGNED:	DATE:
CHECKED:	DATE:
CO SIGNED:	DATE:
APPROVED:	DATE:

DWG. NO.	XB-CSCC-215
PART NO.	

TITLE:
 Pitch 1.00 Fmale Connector
 MINI PCI 30PIN SMT
 TYPE

REV. 01	UNIT. mm	SCALE. 5:3	PAGE. 1/1
---------	----------	------------	-----------

49PIN

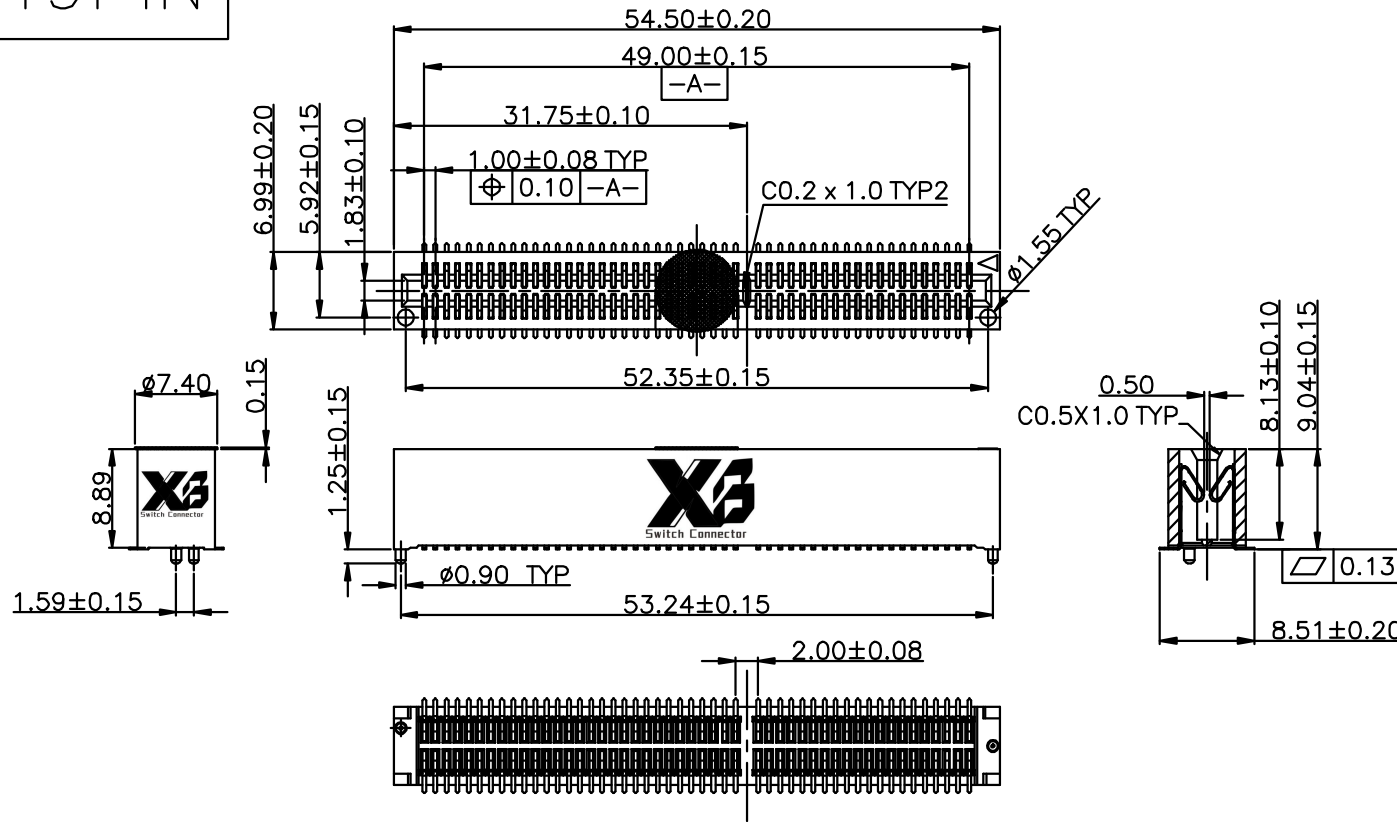

Specifications
 Current Rating:1.0Amp
 Insulation Resistance:1000M Ω Min.
 Dielectric Withstanding Voltage:300VAC
 Contact Resistance:20m Ω Max.
 Operating Temperature:-40°C to +105°C
 Materials
 Contact Material:Phosphor Bronze
 Insulator Material:High Temperature Thermoplastic, UL 94V-0 LCP or the equivalent material
 All materials must meet XI BANG hazardous substances control standards.

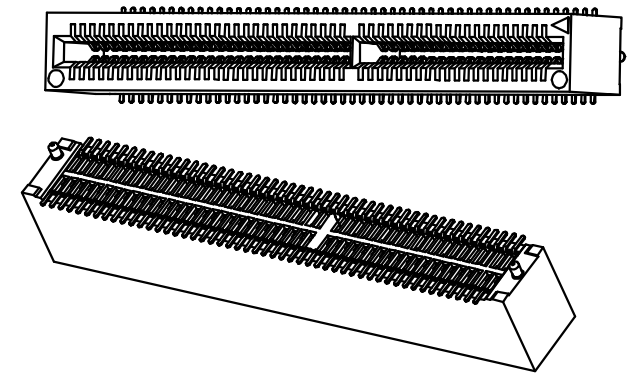

Recommended P.C.Board Layout
 (Tolerance:±0.05)

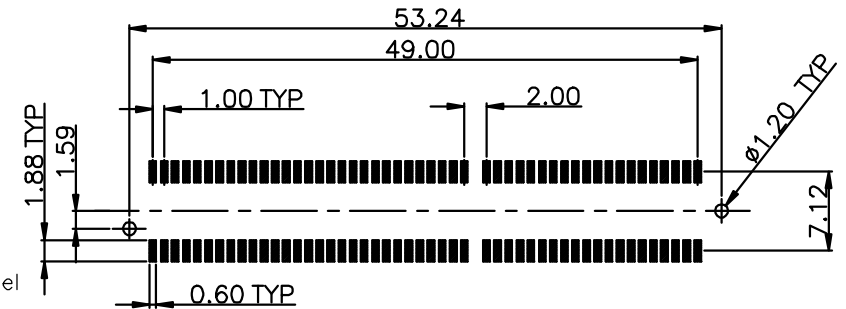

Ordering Information

C SCC215 - 49 XX B 001 C 1 A X

No. of Pins per Row
49

Standard Plating
02=Gold Flash
Selective Plating
01=Tin
05=Gold Flash/Tin
45=10u" Gold on conatct point ,
Matte Tin on tail(Matte Tin 80~160u")

Color
1=Black

Standard Packing
C=Tube
Selective Packing
A=Box
G=Acetate Tape+Tube
H=Acetate Tape+Tape&Reel
D=Tape&Reel

XB 东莞市溪榜电子有限公司
 DONG GUAN XI BANG ELECTRONICS CO., LTD.

GENERAL TOLERANCE

X: ±5.0'	X. ±0.30
.X' ±3.0'	.X ±0.25
.XX' ±2.0'	.XX ±0.15
.XXX' ±1.0'	.XXX ±0.10

DESIGNED:

DATE:

DWG. NO.

TITLE.

CHECKED:

DATE:

XB-CSCC-215

1.00 FEMALE HEADER
 DAUL ROWS SMT TYPE
 CONNECTOR

CO SIGNED:

DATE:

PART NO.

APPROVED:

DATE:

REV.	UNIT.	SCALE.	PAGE.
01	mm	2:1	1/1