

CAD FILE:

REV.	DESCRIPTION	DRAWN	DATE
1	INITIAL RELEASE	TIM	2020/06/10

ROHS

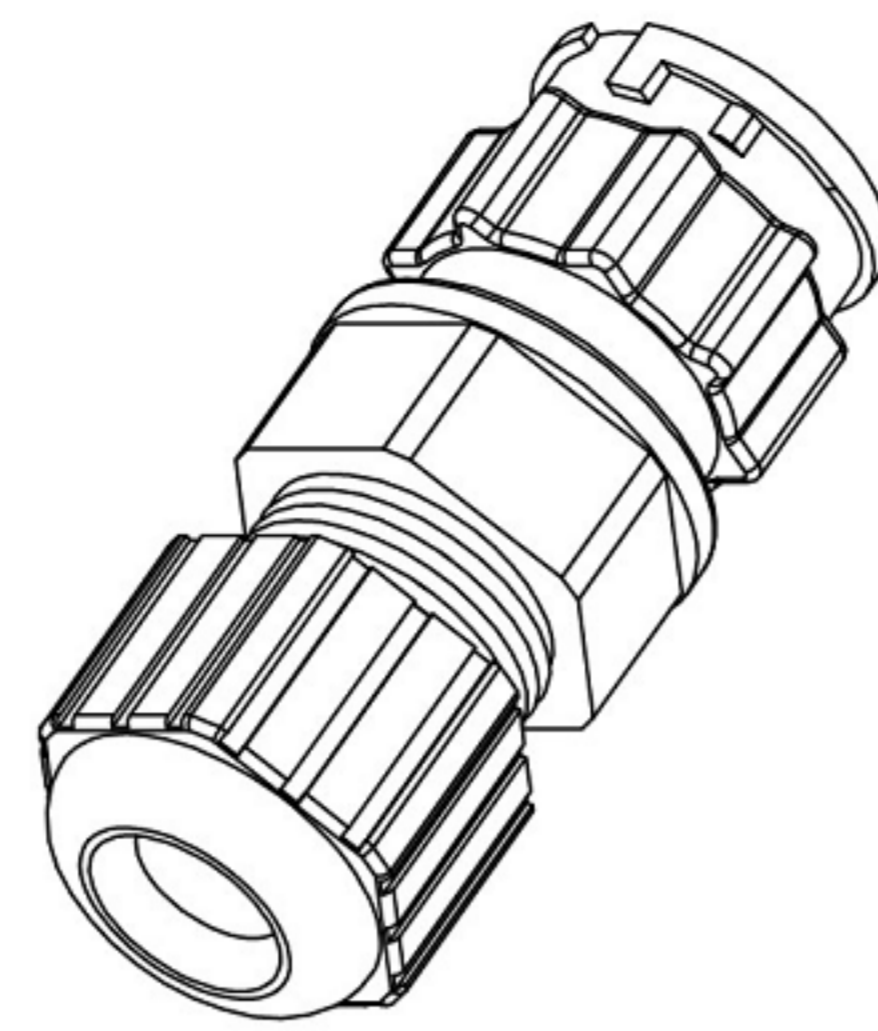
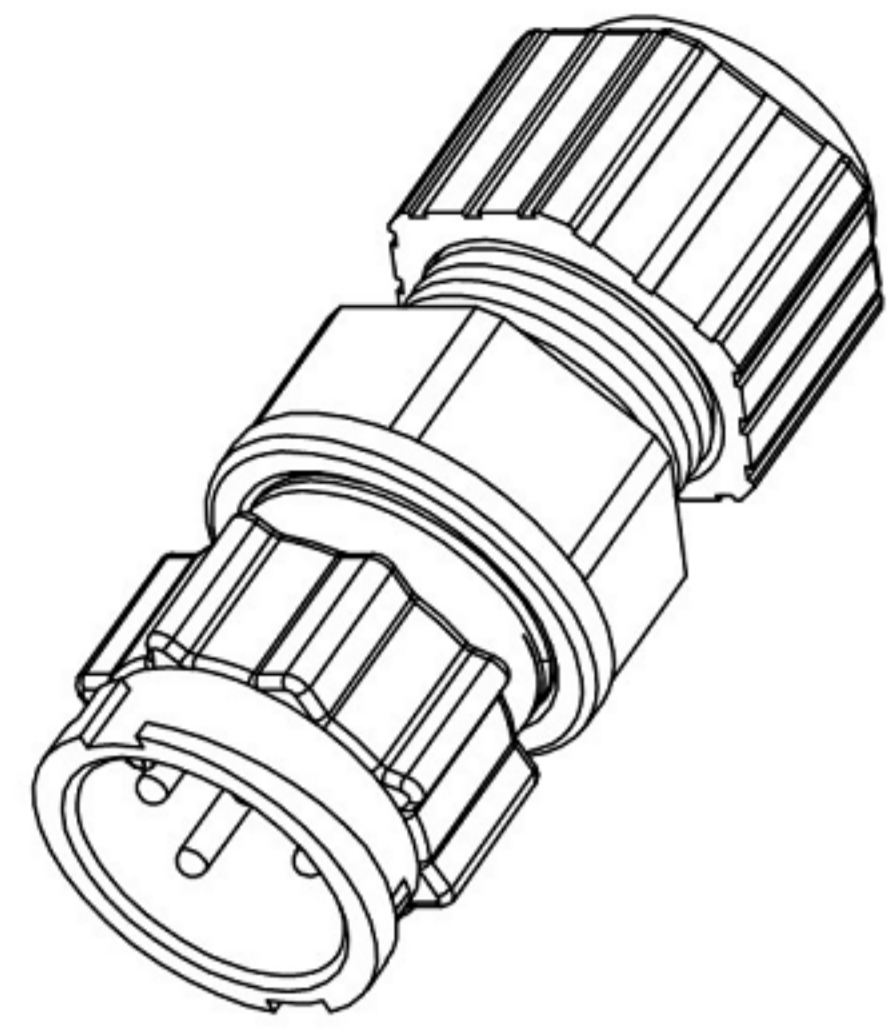

SPECIFICATION:

1. Current Rating: 10A /20A per pin (see P2. table)
2. Contact Resistance: 10mΩ
3. Insulation Resistance: 100MΩ
4. Dielectric Withstanding Voltage: 500VAC
5. Durability: 1000 Cycle
6. Operating temperature range: -40°C~+85°C
7. Storage temperature range: -40°C~+85°C
8. Waterproof: IP67

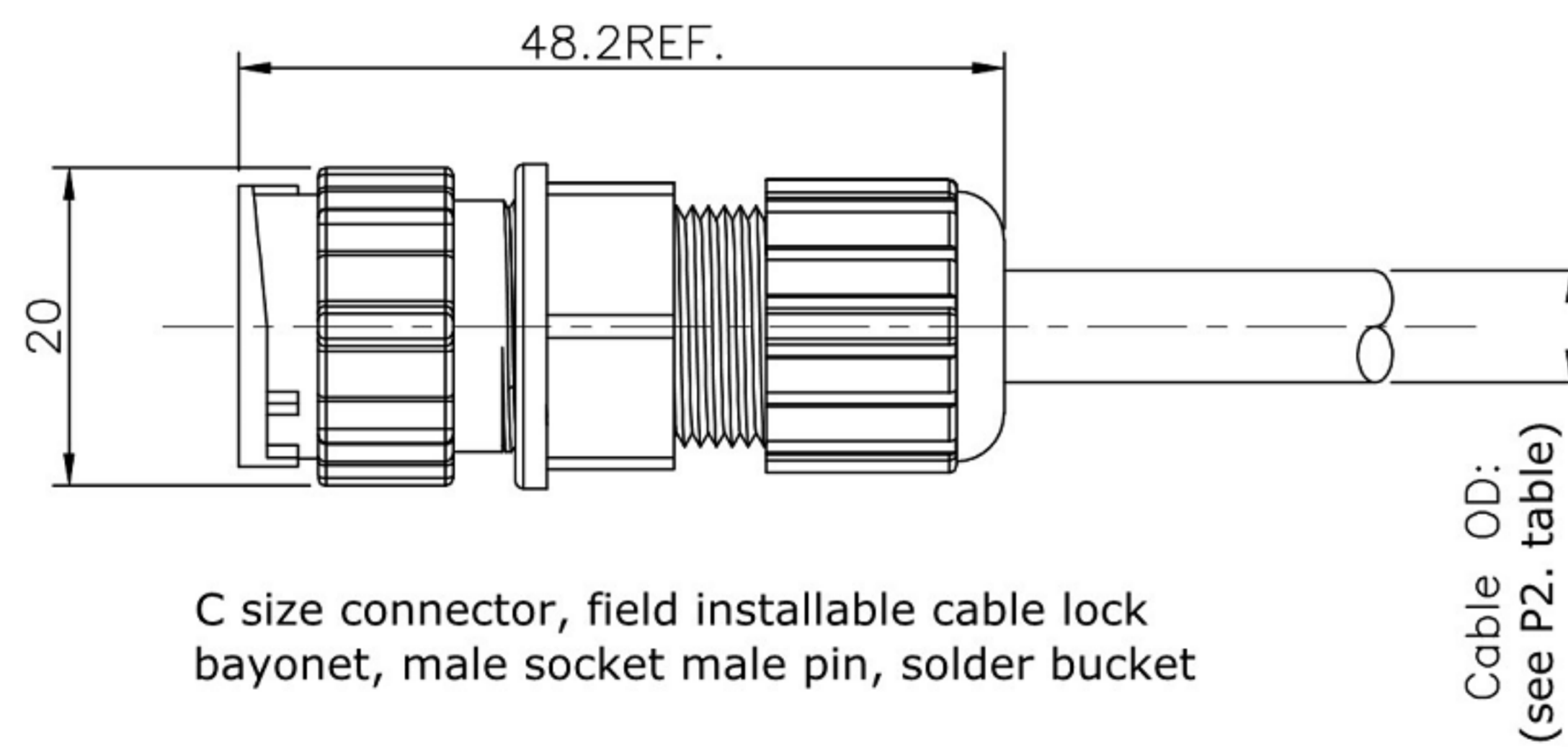
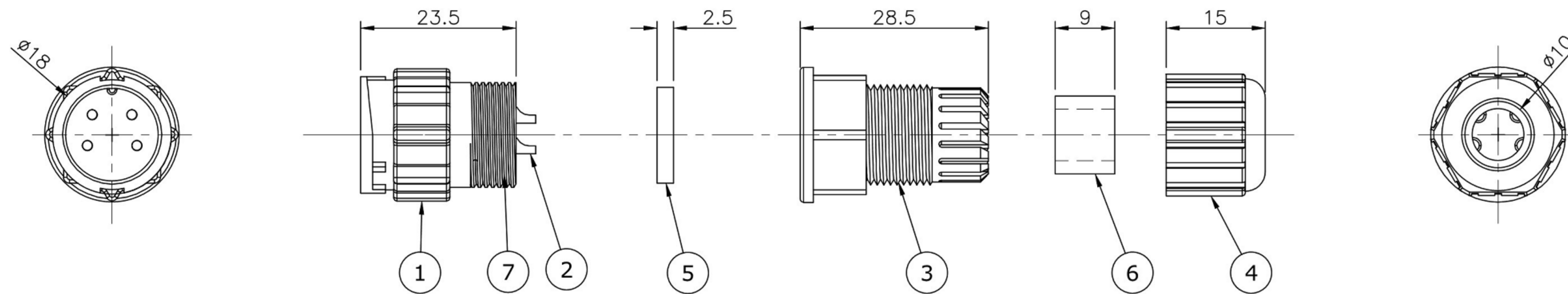

C size connector, field installable cable lock bayonet, male socket male pin, solder bucket

7	GLUE	EPOXY
6	CABLE SEAL	Silicone, Gray
5	GASKET	Silicone, Gray
4	SEALING NUT	PA66, Black
3	CLAMP RING	PA66, UL94V-0, Black
2	CONTACT	Brass, 1u" Min. Gold Plating over Nickel
1	HOUSING	PA66, UL94V-0, Black
NO.	PART NAME	DESCRIPTION

NO.	PARTS	MATERIALS	Q'TY	FINISH	TOLERANCE UNLESS SPECIFIED	DATE	DESCRIPTIONS OF REVISION	APPD.
8					WITHIN 1.5mm : ±0.1mm	2012-9-25	初版	ZENQ. CHEN
7					OVER 1.5mm : ±0.2mm	ISSUE	DATE	APPD.
4	CONTACT	SUS	1	Ag CLAD	TITLE : 圆形连接器		UNIT : mm	DRWG NO.: XB-227C-AMM0
3	CASE	PPA/BRASS SRTIP	1	BLACK/Ag PLATED	MODEL: Circular Connector		SCALE: 5:1	DWN. JUN. YANG 2012-9-25
2	COVER	STEEL STRIP	1	Ni PLATED	 东莞市溪榜电子有限公司 DONG GUAN XI BANG ELECTRONI CS CO., LTD.		CHK'D	DONG. PANG 2012-9-25
1	KNOB	PPA	1	BLACK			APPD.	ZENQ. CHEN 2012-9-25

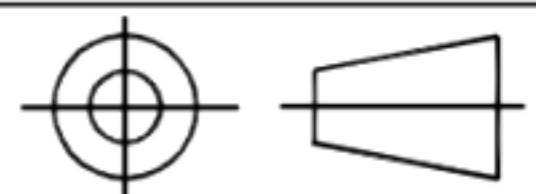

CAD FILE:

REV.	DESCRIPTION	DRAWN	DATE
	SEE SHEET ONE		

ROHS

TABLE: Pin Count/ Pin Assignment/ Current Rating/ Part Number

Part Number	227C-03M02	227C-04M02
Pin Assignment		
Pin Count	3Pin	4Pin
Current Rating	20A	10A
Cable OD	ø8.6mm~ø9.6mm	ø6.5mm~ø7.6mm

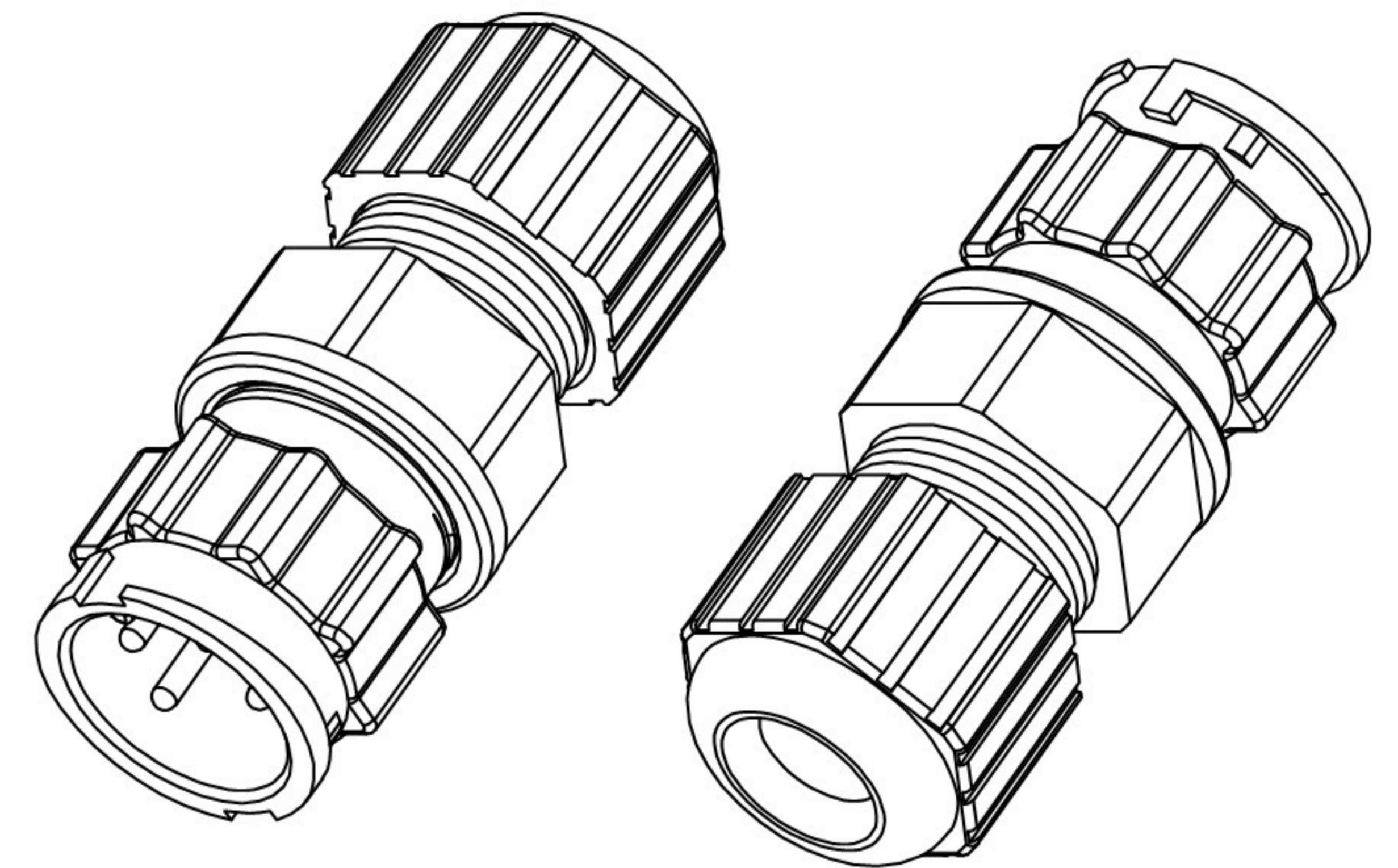

Drawing Number: 227C-AMM0
 Description: C size connector, field installable cable lock bayonet, male socket male pin, solder bucket

8					TOLERANCE				
7					UNLESS SPECIFIED				
6					WITHIN 1.5mm : ±0.1mm	A	2012-9-25	初版	ZENQ. CHEN
5					OVER 1.5mm : ±0.2mm	ISSUE	DATE	DESCRIPTIONS OF REVISION	APPD.
4	CONTACT	SUS	1	Ag CLAD	TITLE : 圆形连接器			UNIT : mm	DRWG NO.: XB-227C-AMM0
3	CASE	PPA/BRASS SRTIP	1	BLACK/Ag PLATED	MODEL: Circular Connector			SCALE: 5:1	DWN. JUN. YANG 2012-9-25
2	COVER	STEEL STRIP	1	Ni PLATED	东莞市溪榜电子有限公司 DONG GUAN XI BANG ELECTRONI CS CO., LTD.			CHK'D	DONG. PANG 2012-9-25
1	KNOB	PPA	1	BLACK				APPD.	ZENQ. CHEN 2012-9-25
NO.	PARTS	MATERIALS	Q'TY	FINISH					

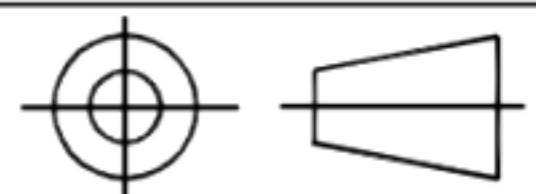

CAD FILE:

REV.	DESCRIPTION	DRAWN	DATE
	SEE SHEET ONE		

ROHS

1. Pre-assembled cable clamp

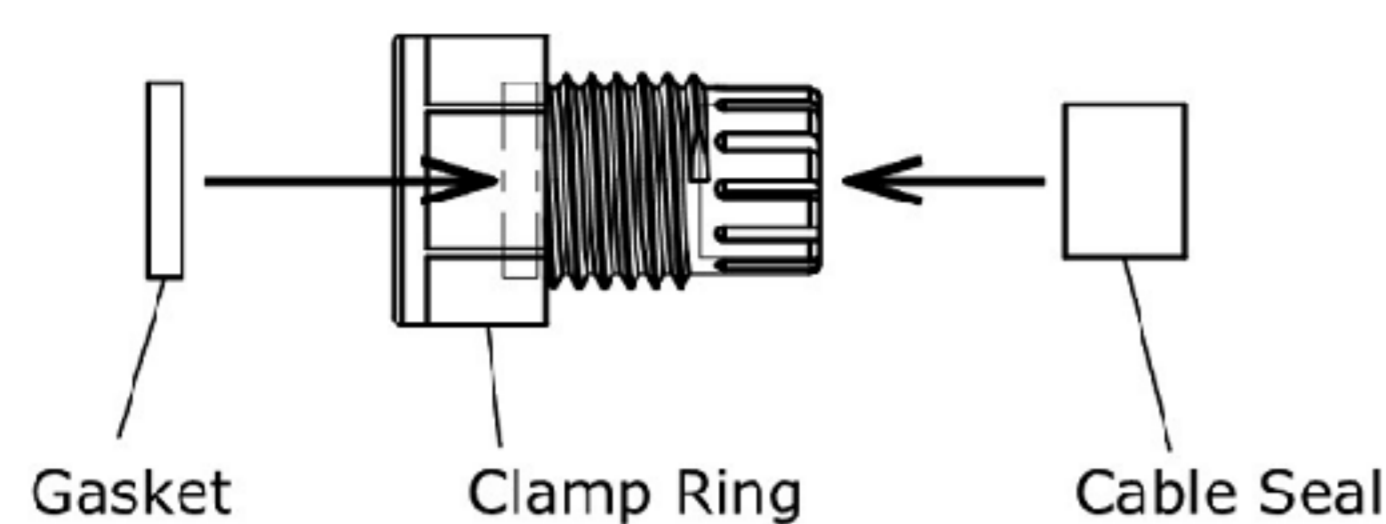

2. Wire processing

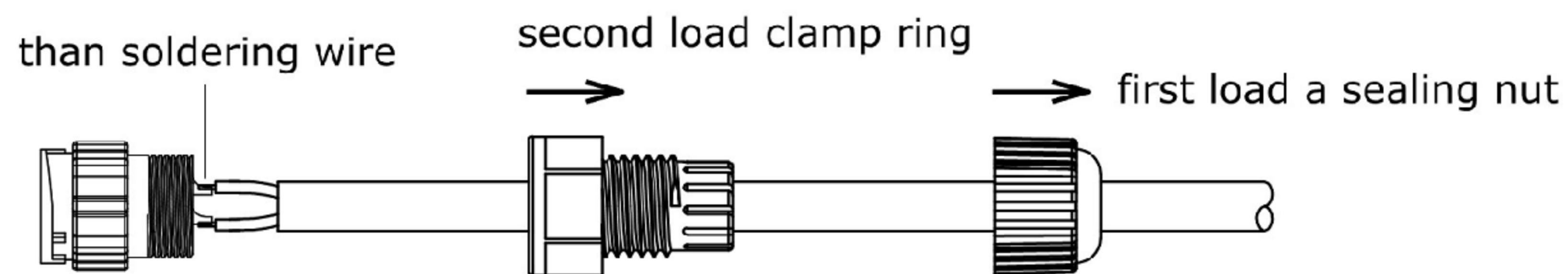

3. Assembly clamp ring

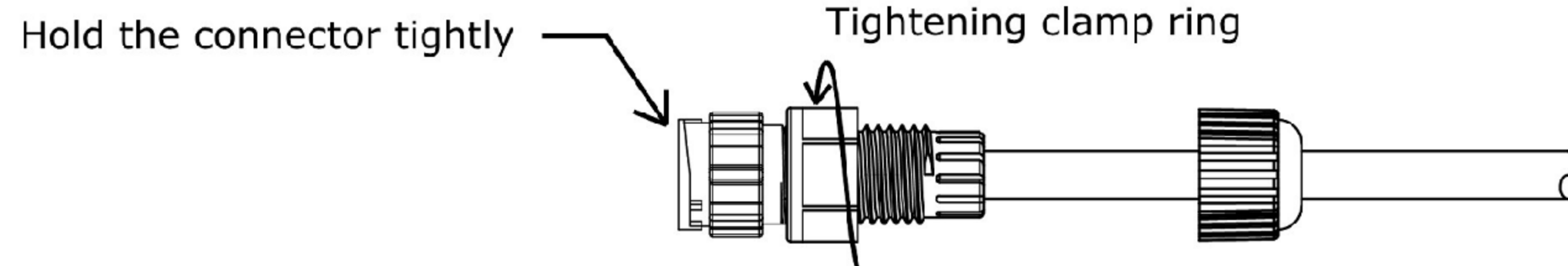

4. Assembly sealing nut

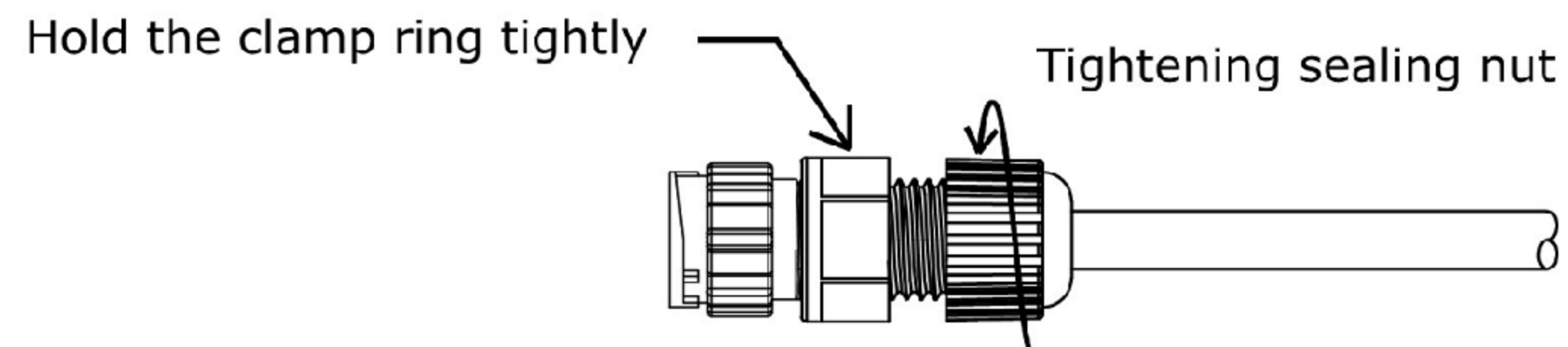

8					TOLERANCE				
7					UNLESS SPECIFIED				
6					WITHIN 1.5mm : ±0.1mm	A	2012-9-25	初版	ZENQ. CHEN
5					OVER 1.5mm : ±0.2mm	ISSUE	DATE	DESCRIPTIONS OF REVISION	APPD.
4	CONTACT	SUS	1	Ag CLAD	TITLE : 圆形连接器			UNIT : mm	DRWG NO.: XB-227C-AMM0
3	CASE	PPA/BRASS SRTIP	1	BLACK/Ag PLATED	MODEL: Circular Connector			SCALE: 5:1	DWN. JUN. YANG 2012-9-25
2	COVER	STEEL STRIP	1	Ni PLATED	东莞市溪榜电子有限公司 DONG GUAN XI BANG ELECTRONICS CO., LTD.			CHK'D	DONG. PANG 2012-9-25
1	KNOB	PPA	1	BLACK				APPD.	ZENQ. CHEN 2012-9-25
NO.	PARTS	MATERIALS	Q'TY	FINISH					

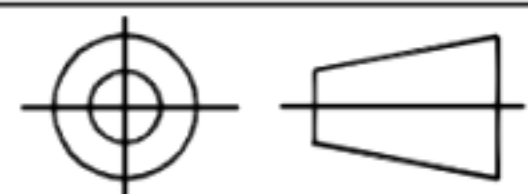

CAD FILE:

REV.	DESCRIPTION	DRAWN	DATE
1	INITIAL RELEASE	TIM	2020/06/10

ROHS

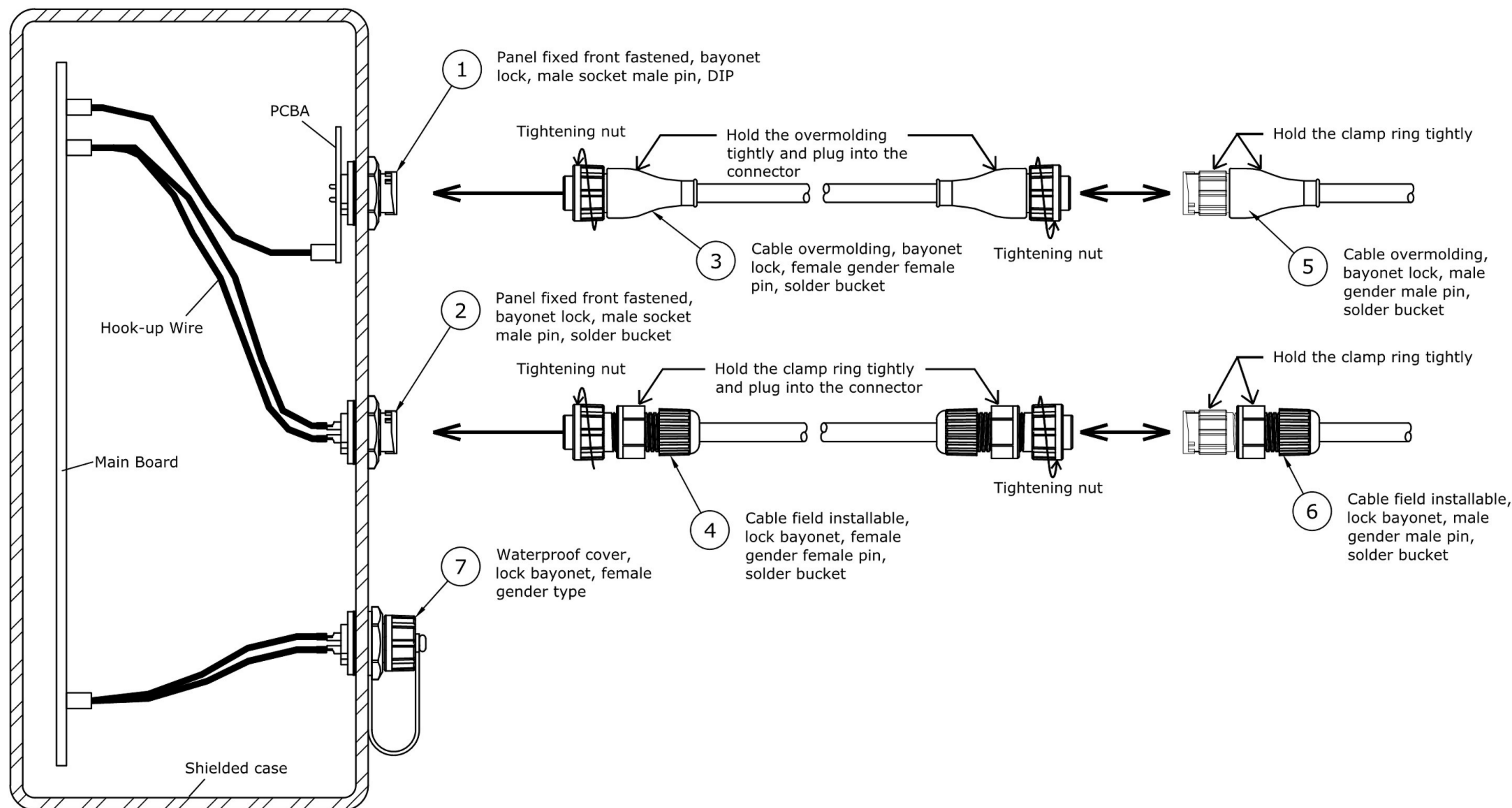

NO.	PARTS	MATERIALS	Q'TY	FINISH	TOLERANCE UNLESS SPECIFIED				
8					TOLERANCE UNLESS SPECIFIED				
7					TOLERANCE UNLESS SPECIFIED				
6					WITHIN 1.5mm : ±0.1mm	A	2012-9-25	初版	ZENQ. CHEN
5					OVER 1.5mm : ±0.2mm	ISSUE	DATE	DESCRIPTIONS OF REVISION	APPD.
4	CONTACT	SUS	1	Ag CLAD	TITLE : 圆形连接器			UNIT : mm	DRWG NO.: XB-227C-AMM0
3	CASE	PPA/BRASS SRTIP	1	BLACK/Ag PLATED	MODEL: Circular Connector			SCALE: 5:1	DWN. JUN. YANG 2012-9-25
2	COVER	STEEL STRIP	1	Ni PLATED	东莞市溪榜电子有限公司 DONG GUAN XI BANG ELECTRONICS CO., LTD.			CHK'D	DONG. PANG 2012-9-25
1	KNOB	PPA	1	BLACK				APPD.	ZENQ. CHEN 2012-9-25