

CAD FILE:

REV.	DESCRIPTION	DRAWN	DATE
1	INITIAL RELEASE	TIM	2020/06/10

ROHS

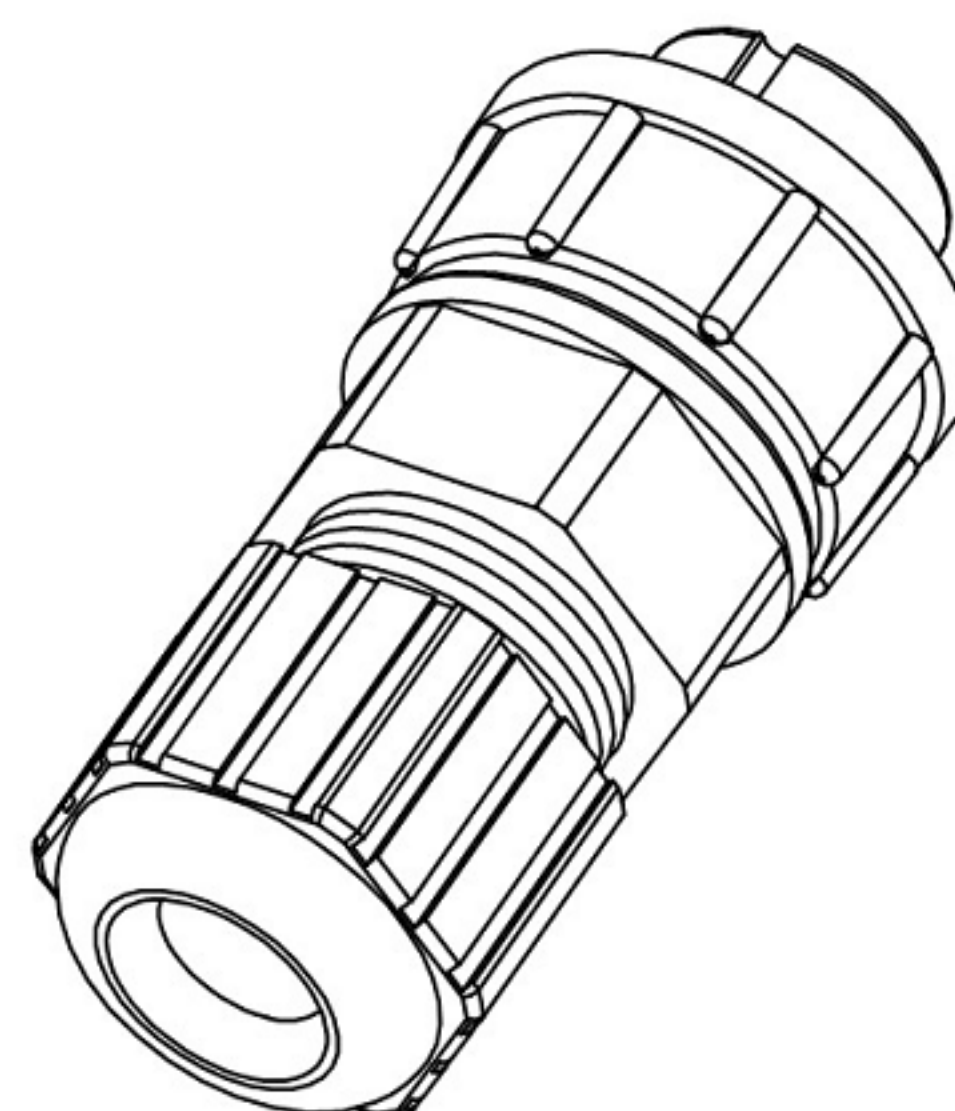
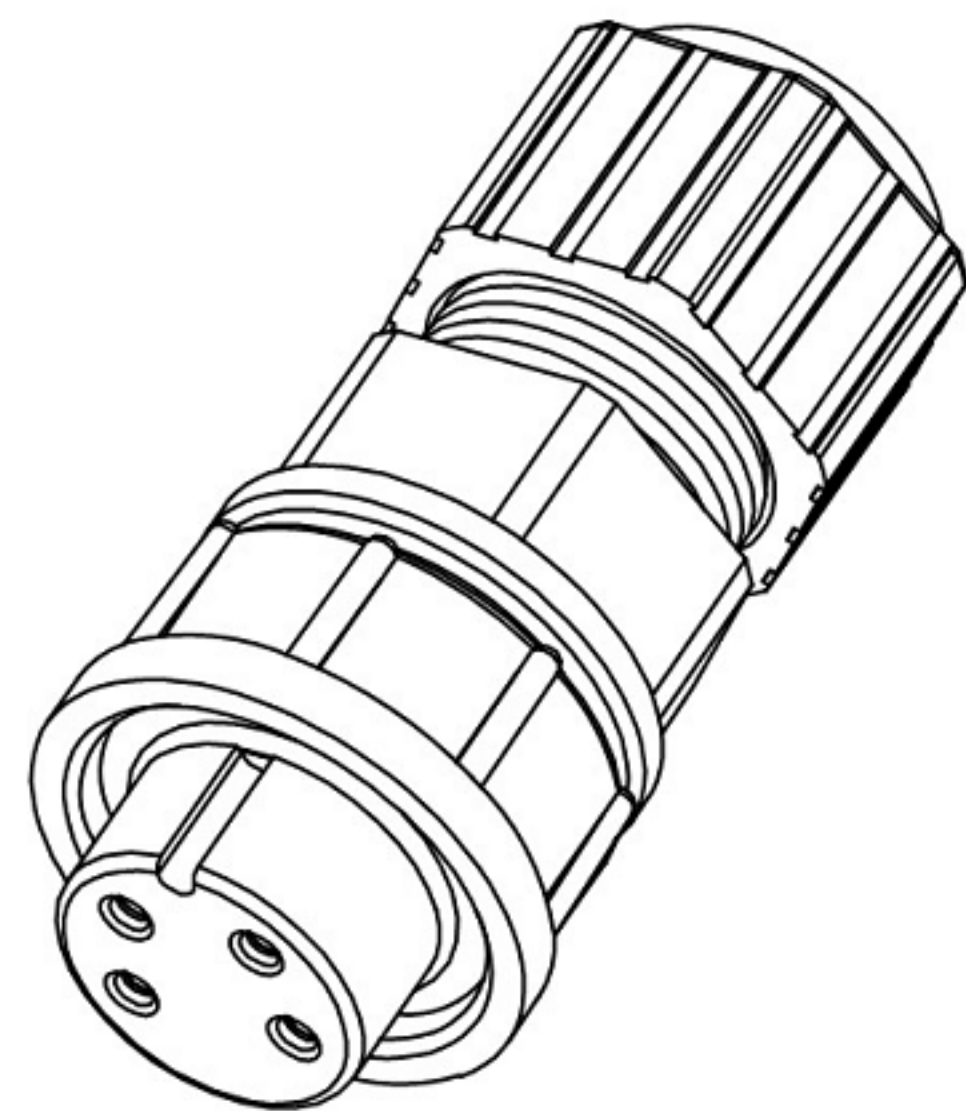

SPECIFICATION:

1. Current Rating: 2A/ 5A/ 10A /20A per pin (see P2. table)
2. Contact Resistance: 10mΩ
3. Insulation Resistance: 100MΩ
4. Dielectric Withstanding Voltage: 500VAC
5. Durability: 1000 Cycle
6. Operating temperature range: -40°C~+85°C
7. Storage temperature range: -40°C~+85°C
8. Waterproof: IP67

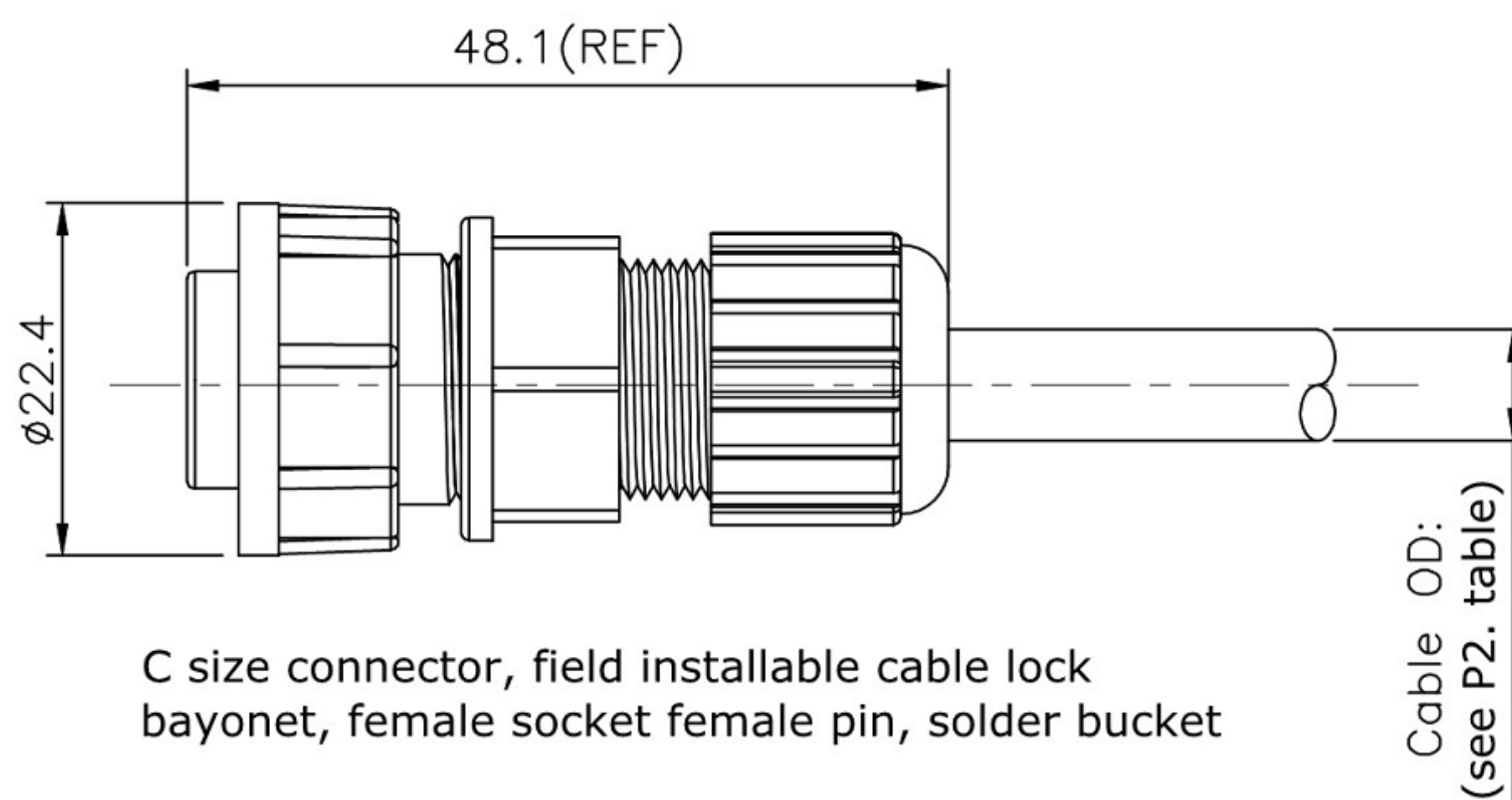
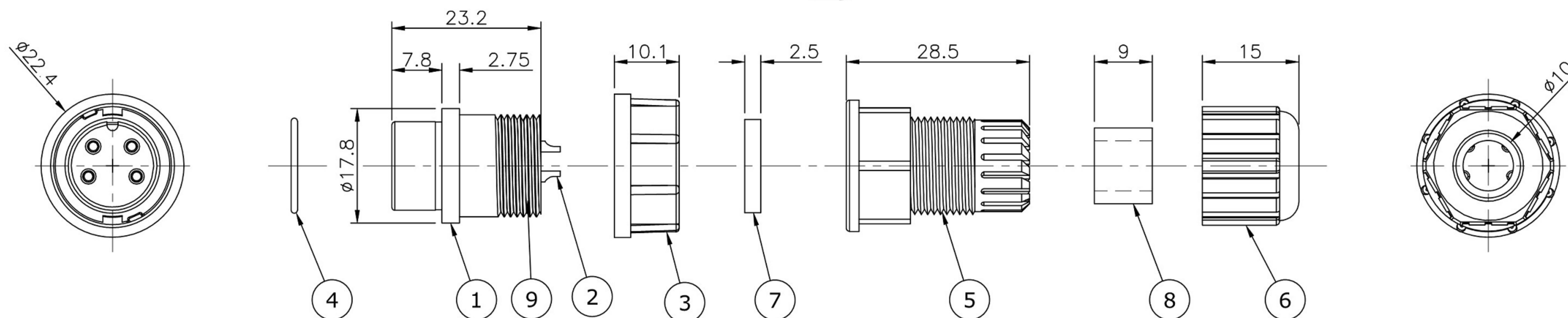

C size connector, field installable cable lock bayonet, female socket female pin, solder bucket

9	GLUE	EPOXY
8	CABLE SEAL	Silicone, Gray
7	GASKET	Silicone, Gray
6	SEALING NUT	PA66, Black
5	CLAMP RING	PA66, UL94V-0, Black
4	ORING	Silicone, Gray
3	LOCK NUT	PA66, UL94V-0, Black
2	CONTACT	Brass, 1u" Min. Gold Plating over Nickel
1	HOUSING	PA66, UL94V-0, Black
NO.	PART NAME	DESCRIPTION

NO.	PARTS	MATERIALS	Q'TY	FINISH	TOLERANCE UNLESS SPECIFIED					
8					TOLERANCE UNLESS SPECIFIED					
7					TOLERANCE UNLESS SPECIFIED					
6					WITHIN 1.5mm	±0.1mm	A	2012-9-25	初版	ZENQ. CHEN
5					OVER 1.5mm	±0.2mm	ISSUE	DATE	DESCRIPTIONS OF REVISION	APPD.
4	CONTACT	SUS	1	Ag CLAD	TITLE : 圆形连接器			UNIT : mm	DRWG NO.: XB-227C-AFF0	
3	CASE	PPA/BRASS SRTIP	1	BLACK/Ag PLATED	MODEL: Circular Connector			SCALE: 5:1	DWN.	JUN. YANG 2012-9-25
2	COVER	STEEL STRIP	1	Ni PLATED	东莞市溪榜电子有限公司 DONG GUAN XI BANG ELECTRONICS CO., LTD.			CHK'D	DONG. PANG	2012-9-25
1	KNOB	PPA	1	BLACK				APPD.	ZENQ. CHEN	2012-9-25
NO.	PARTS	MATERIALS	Q'TY	FINISH						

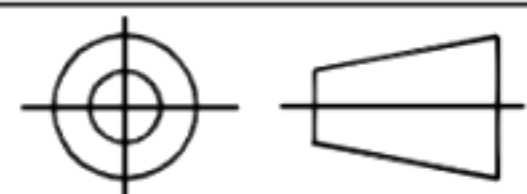

CAD FILE:

REV.	DESCRIPTION	DRAWN	DATE
	SEE SHEET ONE		

ROHS

TABLE: Pin Count/ Pin Assignment/ Current Rating/ Part Number

Part Number	227C-03F02	227C-04F01	227C-05F01	227C-14F01	227C-18F01	227C-20F01
Pin Assignment						
Pin Count	3Pin	4Pin	5Pin	14Pin	18Pin	20Pin
Current Rating	20A	10A	10A	5A	2A	2A
Cable OD	ø8.6mm~ø9.6mm	ø6.5mm~ø7.6mm	ø6.5mm~ø7.6mm	ø6.5mm~ø7.6mm	ø8.6mm~ø9.6mm	ø8.6mm~ø9.6mm

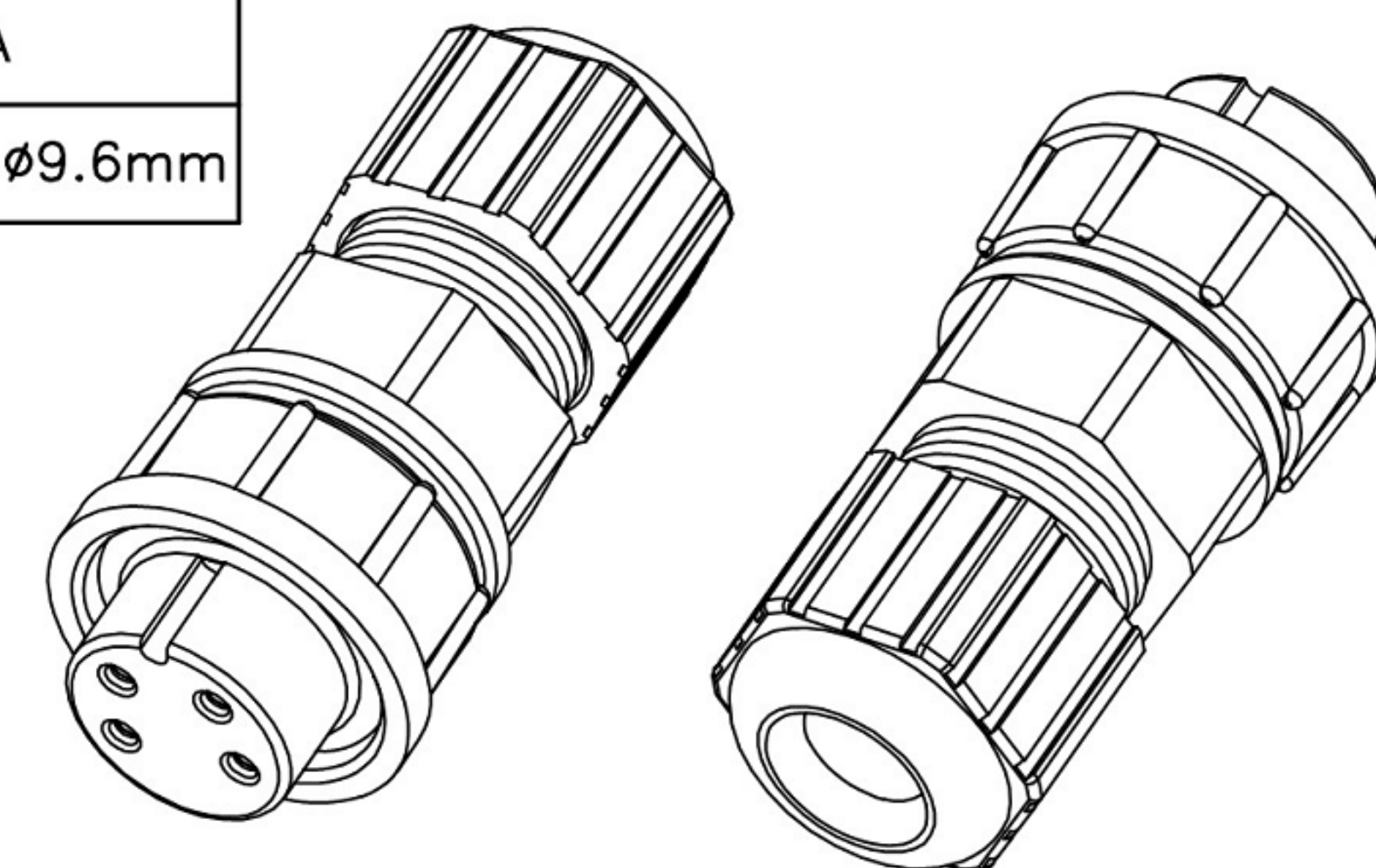

Drawing Number: 227C-AFF0
 Description: C size connector, field installable cable lock bayonet, female socket female pin, solder bucket

8					TOLERANCE						
7					UNLESS SPECIFIED						
6					WITHIN 1.5mm : ±0.1mm	A	2012-9-25	初版		ZENQ. CHEN	
5					OVER 1.5mm : ±0.2mm	ISSUE	DATE	DESCRIPTIONS OF REVISION		APPD.	
4	CONTACT	SUS	1	Ag CLAD	TITLE : 圆形连接器			UNIT : mm	DRWG NO.: XB-227C-AFF0		
3	CASE	PPA/BRASS SRTIP	1	BLACK/Ag PLATED	MODEL: Circular Connector			SCALE: 5:1	DWN.	JUN. YANG	2012-9-25
2	COVER	STEEL STRIP	1	Ni PLATED	东莞市溪榜电子有限公司 DONG GUAN XI BANG ELECTRONICS CO., LTD.			CHK'D	DONG. PANG	2012-9-25	
1	KNOB	PPA	1	BLACK				APPD.	ZENQ. CHEN	2012-9-25	
NO.	PARTS	MATERIALS	Q'TY	FINISH							

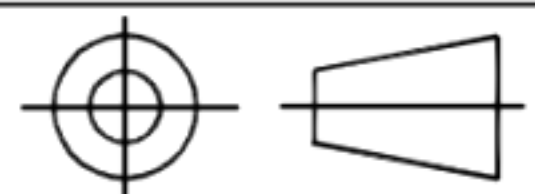

CAD FILE:

REV.	DESCRIPTION	DRAWN	DATE
	SEE SHEET ONE		

ROHS

1. Pre-assembled connector

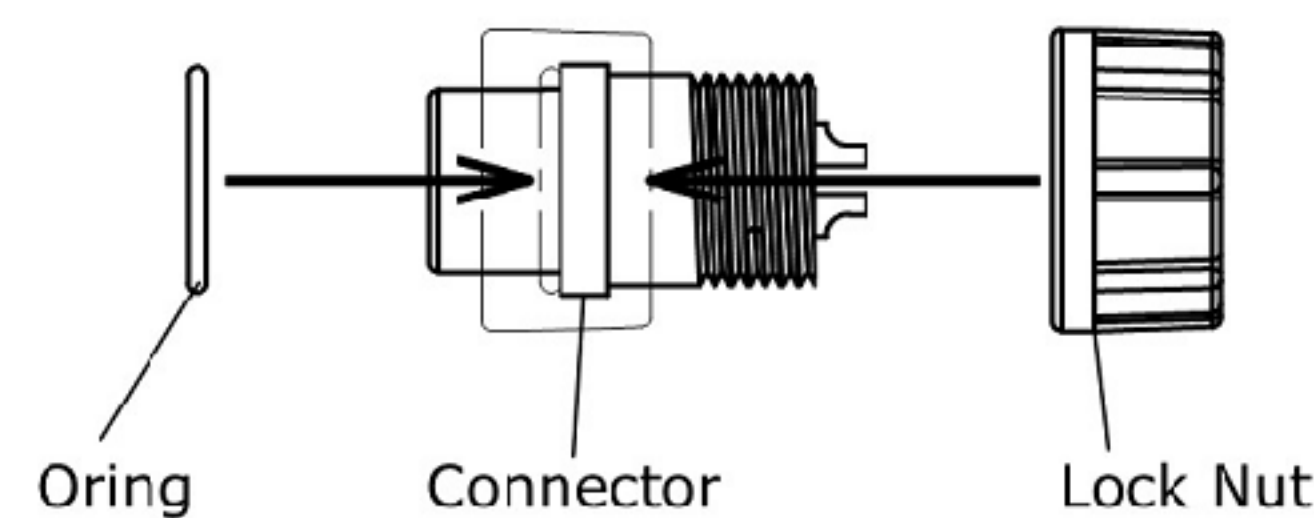

2. Pre-assembled cable clamp

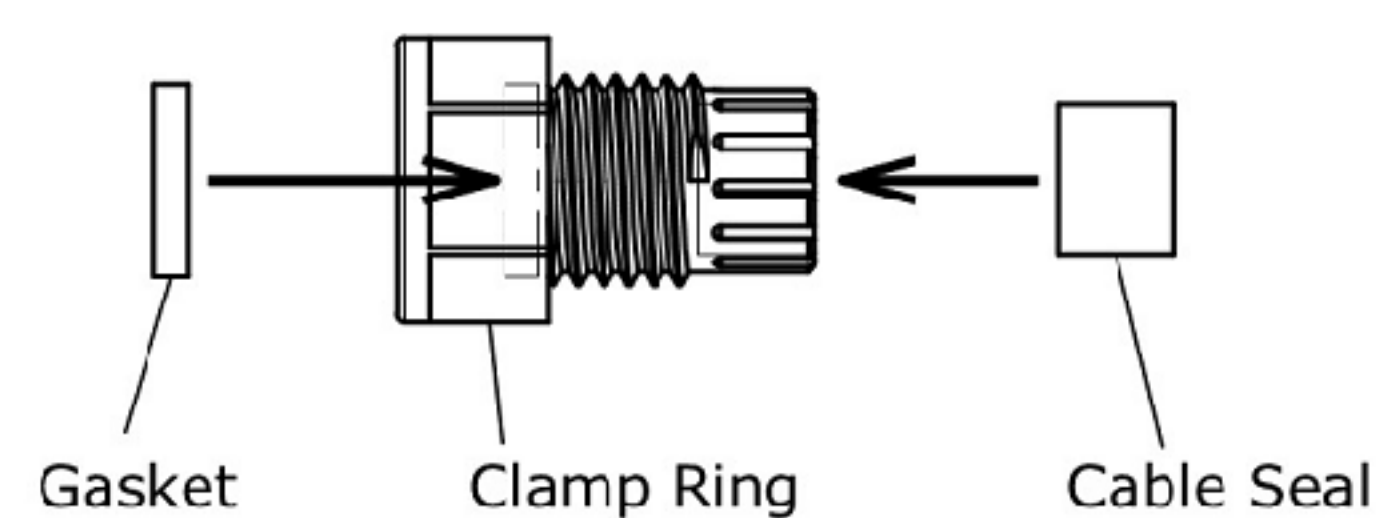

3. Wire processing

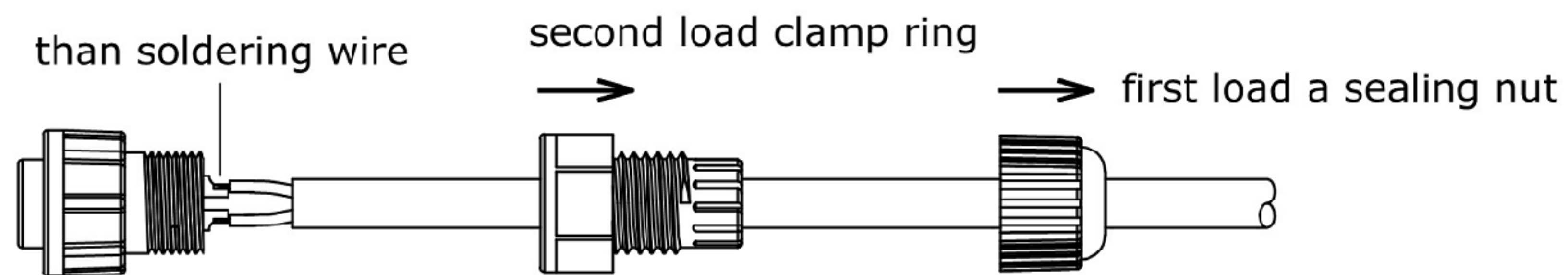

4. Assembly clamp ring

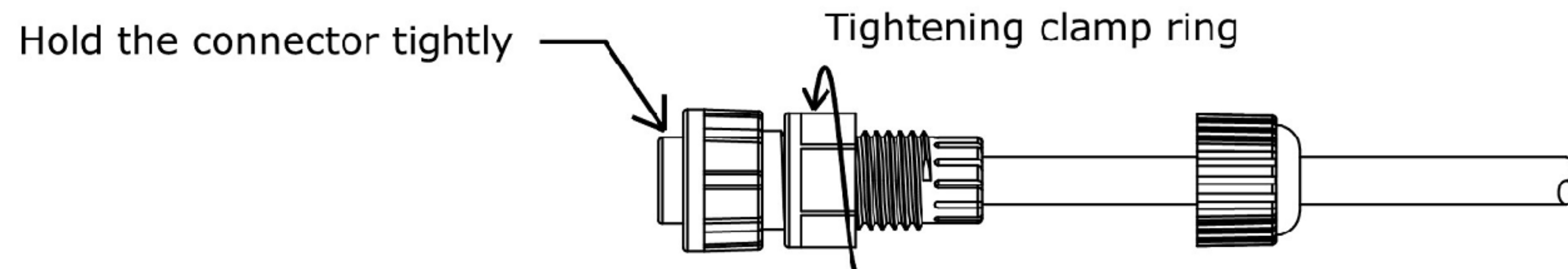

5. Assembly sealing nut

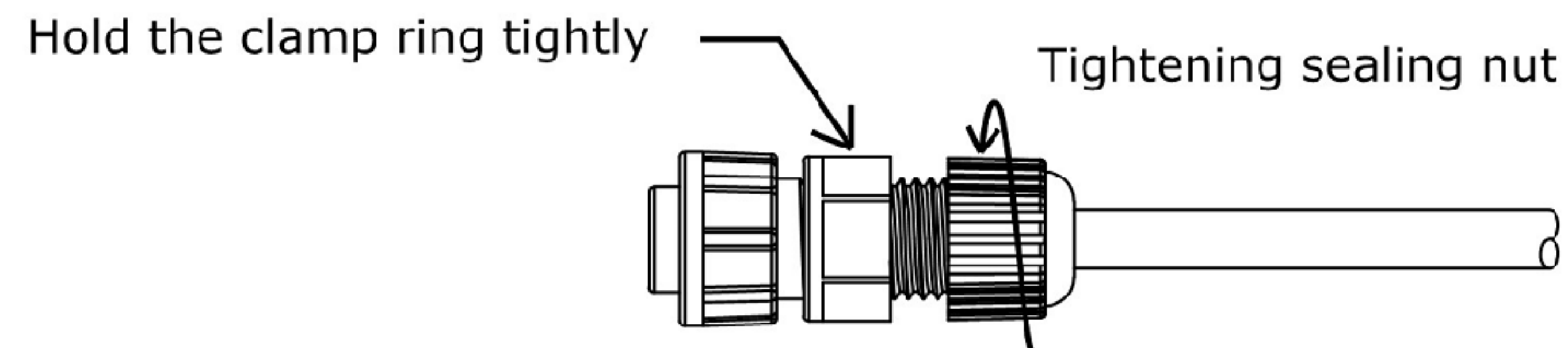

8											
7											
6											
5											
4	CONTACT	SUS	1	Ag CLAD							
3	CASE	PPA/BRASS SRTIP	1	BLACK/Ag PLATED							
2	COVER	STEEL STRIP	1	Ni PLATED							
1	KNOB	PPA	1	BLACK							
NO.	PARTS	MATERIALS	Q'TY	FINISH							
					TOLERANCE UNLESS SPECIFIED						
					WITHIN 1.5mm : ±0.1mm	A	2012-9-25	初版		ZENQ. CHEN	
					OVER 1.5mm : ±0.2mm	ISSUE	DATE	DESCRIPTIONS OF REVISION		APPD.	
					TITLE : 圆形连接器			UNIT : mm	DRWG NO.: XB-227C-AFF0		
					MODEL: Circular Connector			SCALE: 5:1	DWN.	JUN. YANG	2012-9-25
					东莞市溪榜电子有限公司 DONG GUAN XI BANG ELECTRONICS CO., LTD.			CHK'D	DONG. PANG	2012-9-25	
								APPD.	ZENQ. CHEN	2012-9-25	

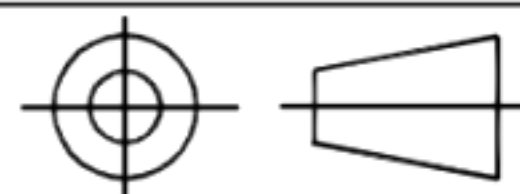

CAD FILE:

REV.	DESCRIPTION	DRAWN	DATE
1	INITIAL RELEASE	TIM	2020/06/10

ROHS

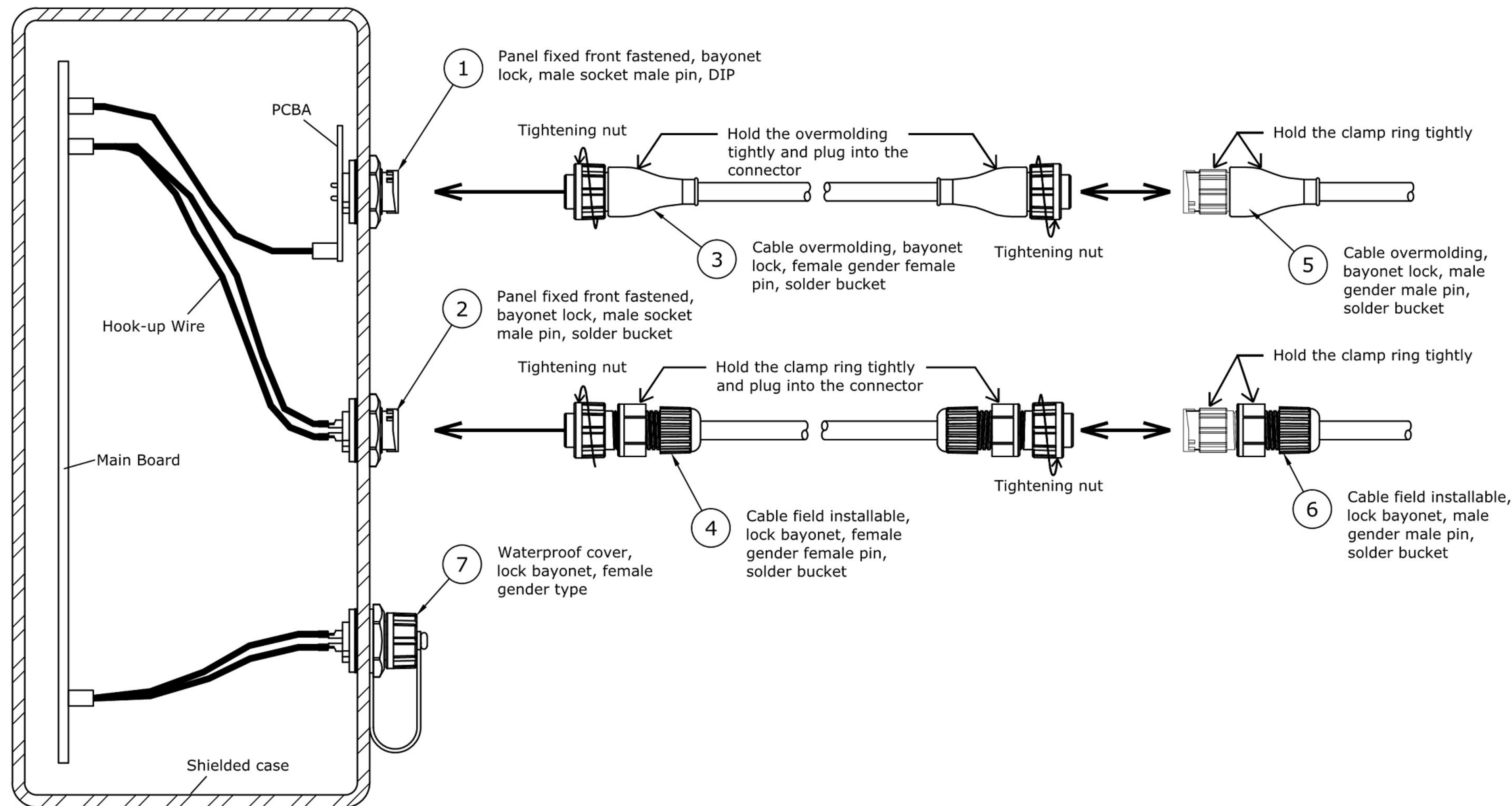

NO.	PARTS	MATERIALS	Q'TY	FINISH							
8					TOLERANCE UNLESS SPECIFIED						
7											
6					WITHIN 1.5mm : ±0.1mm	A	2012-9-25	初版	ZENQ. CHEN		
5					OVER 1.5mm : ±0.2mm	ISSUE	DATE	DESCRIPTIONS OF REVISION	APPD.		
4	CONTACT	SUS	1	Ag CLAD	TITLE : 圆形连接器			UNIT : mm	DRWG NO.: XB-227C-AFF0		
3	CASE	PPA/BRASS SRTIP	1	BLACK/Ag PLATED	MODEL: Circular Connector			SCALE: 5:1	DWN.	JUN. YANG	2012-9-25
2	COVER	STEEL STRIP	1	Ni PLATED	东莞市溪榜电子有限公司 DONG GUAN XI BANG ELECTRONICS CO., LTD.			CHK'D	DONG. PANG	2012-9-25	
1	KNOB	PPA	1	BLACK				APPD.	ZENQ. CHEN	2012-9-25	