

CAD FILE:

ROHS

REV.	DESCRIPTION	DRAWN	DATE
1	INITIAL RELEASE	FROS	2020/06/10

SPECIFICATION:

1. Current Rating: 2A/ 5A per pin (see P2. table)
2. Contact Resistance: 10mΩ
3. Insulation Resistance: 100MΩ
4. Dielectric Withstanding Voltage: 500VAC
5. Durability: 1000 Cycle
6. Operating temperature range: -40°C~+85°C
7. Storage temperature range: -40°C~+85°C
8. Water Proof: IP67

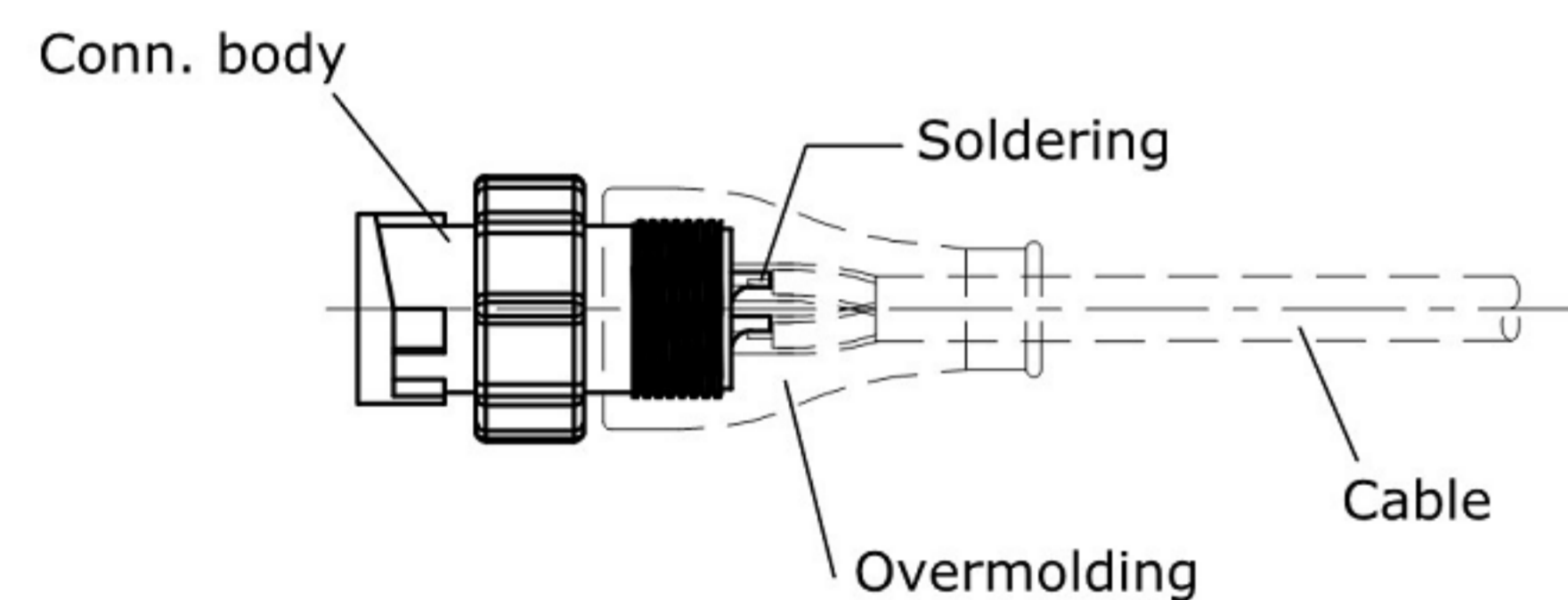
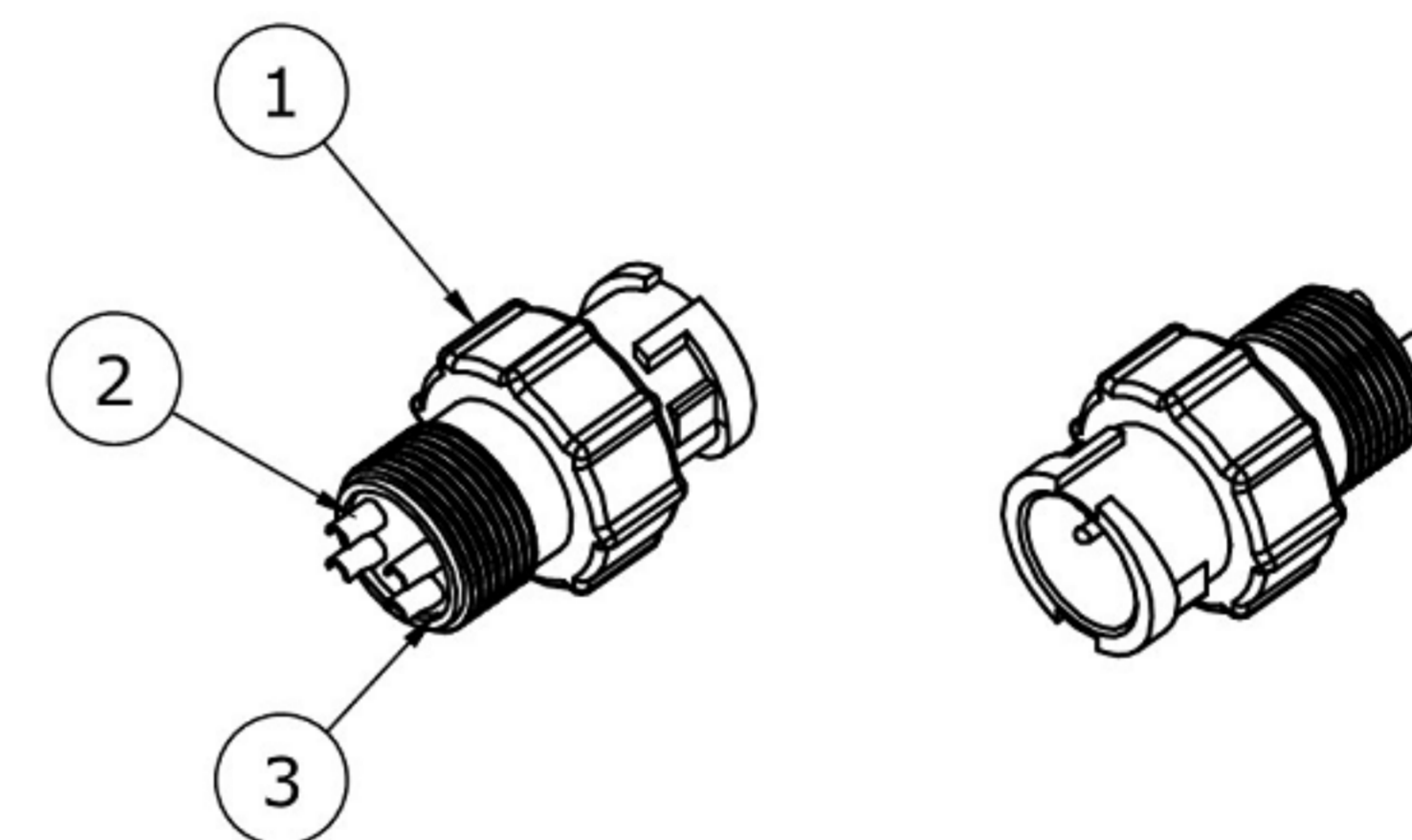
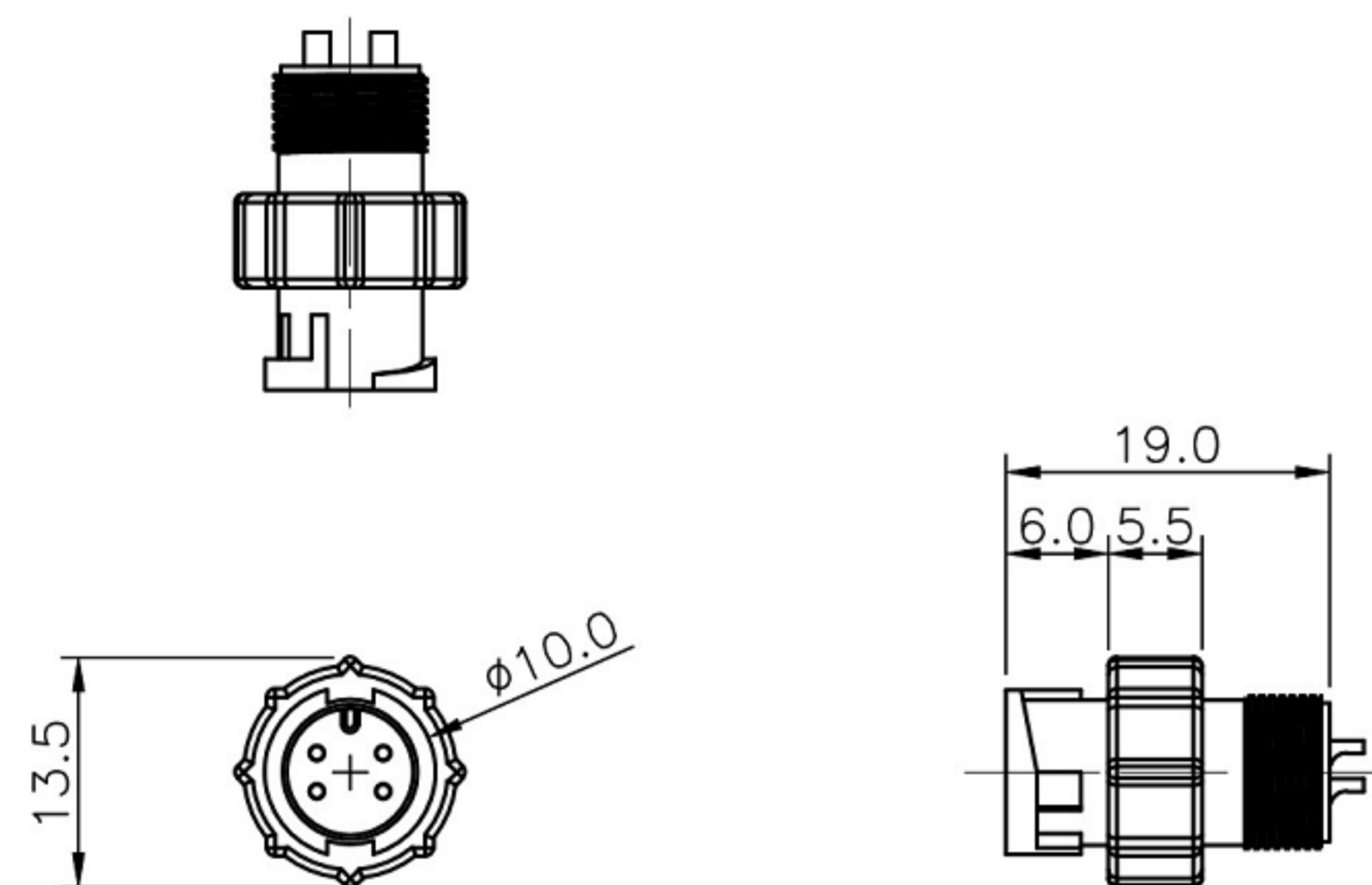

Cable overmolding, bayonet lock, male gender male pin, solder bucket

NO.	PARTS	MATERIALS	Q'TY	FINISH	TOLERANCE UNLESS SPECIFIED	ISSUE	DATE	DESCRIPTIONS OF REVISION	APPD.
8									
7									
6					WITHIN 1.5mm : ±0.1mm	A	2012-9-25	初版	ZENQ. CHEN
5					OVER 1.5mm : ±0.2mm	ISSUE	DATE	DESCRIPTIONS OF REVISION	APPD.
4	CONTACT	SUS	1	Ag CLAD	TITLE : 圆形连接器			UNIT : mm	DRWG NO.: XB-227A-MMM0
3	CASE	PPA/BRASS SRTIP	1	BLACK/Ag PLATED	MODEL: Circular Connector			SCALE: 5:1	DWN. JUN. YANG 2012-9-25
2	COVER	STEEL STRIP	1	Ni PLATED	东莞市溪榜电子有限公司 DONG GUAN XI BANG ELECTRONI CS CO., LTD.			CHK'D	DONG. PANG 2012-9-25
1	KNOB	PPA	1	BLACK				APPD.	ZENQ. CHEN 2012-9-25

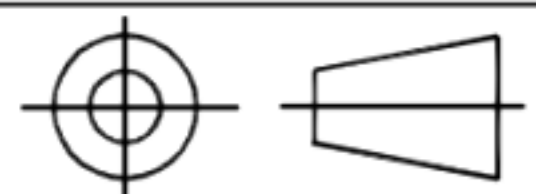

CAD FILE:

ROHS

REV.	DESCRIPTION	DRAWN	DATE
	SEE SHEET ONE		

TABLE: Pin Count/ Pin Assignment/ Current Rating/ Part Number

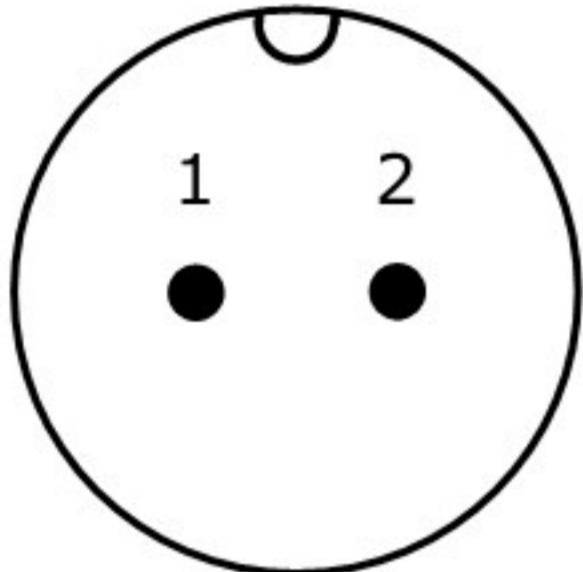
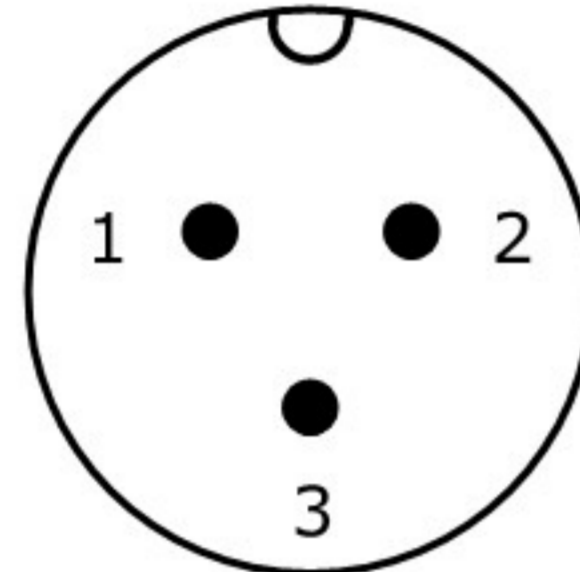
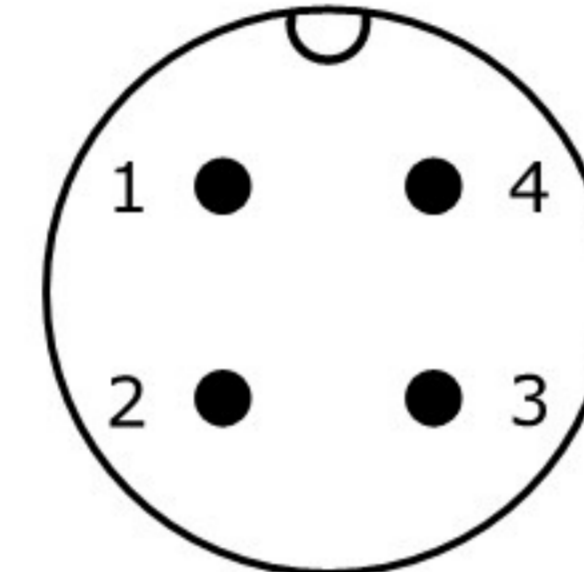
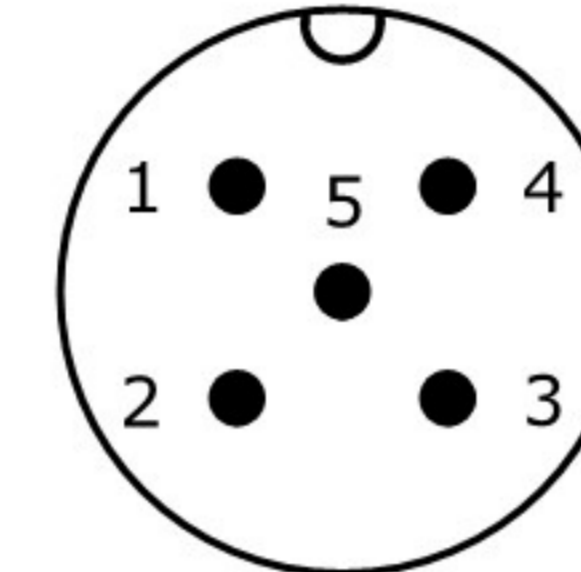
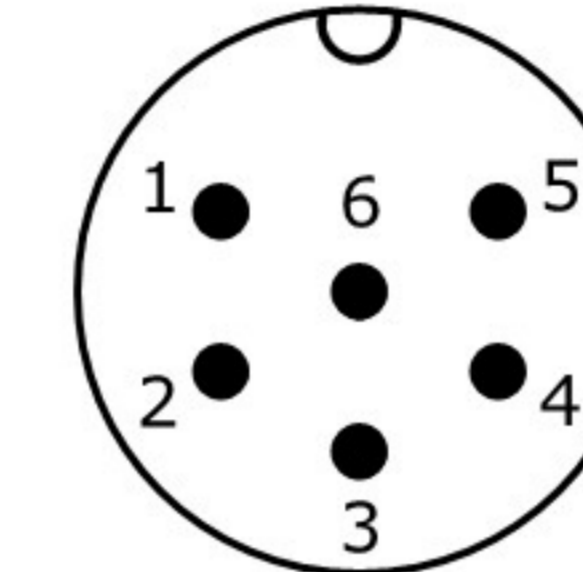
Part Number	227A-02M04	227A-03M04	227A-04M04	227A-05M04	227A-06M04
Pin Assignment					
Pin Count	2Pin	3Pin	4Pin	5Pin	6Pin
Current Rating	5A	5A	2A	2A	2A

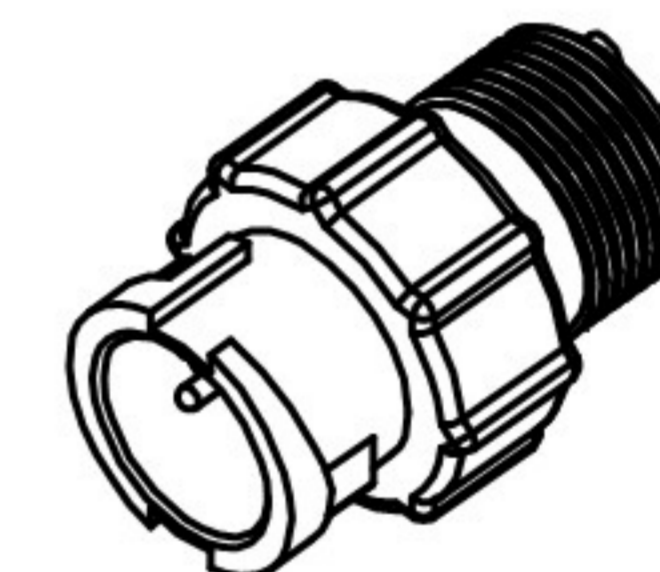

Drawing Number: 227A-MMM0

Description: A size connector, overmolding cable lock bayonet, male socket male pin, solder bucket

8					TOLERANCE						
7					UNLESS SPECIFIED						
6					WITHIN 1.5mm : ±0.1mm	A	2012-9-25	初版		ZENQ. CHEN	
5					OVER 1.5mm : ±0.2mm	ISSUE	DATE	DESCRIPTIONS OF REVISION		APPD.	
4	CONTACT	SUS	1	Ag CLAD	TITLE : 圆形连接器			UNIT : mm	DRWG NO.: XB-227A-MMM0		
3	CASE	PPA/BRASS SRTIP	1	BLACK/Ag PLATED	MODEL: Circular Connector			SCALE: 5:1	DWN.	JUN. YANG	2012-9-25
2	COVER	STEEL STRIP	1	Ni PLATED	 东莞市溪榜电子有限公司 DONG GUAN XI BANG ELECTRONI CS CO., LTD.			CHK'D	DONG. PANG	2012-9-25	
1	KNOB	PPA	1	BLACK				APPD.	ZENQ. CHEN	2012-9-25	
NO.	PARTS	MATERIALS	Q'TY	FINISH							

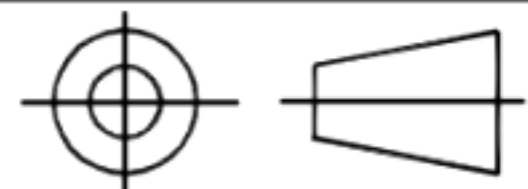

CAD FILE:

ROHS

REV.	DESCRIPTION	DRAWN	DATE
1	INITIAL RELEASE	FROS	2020/06/10

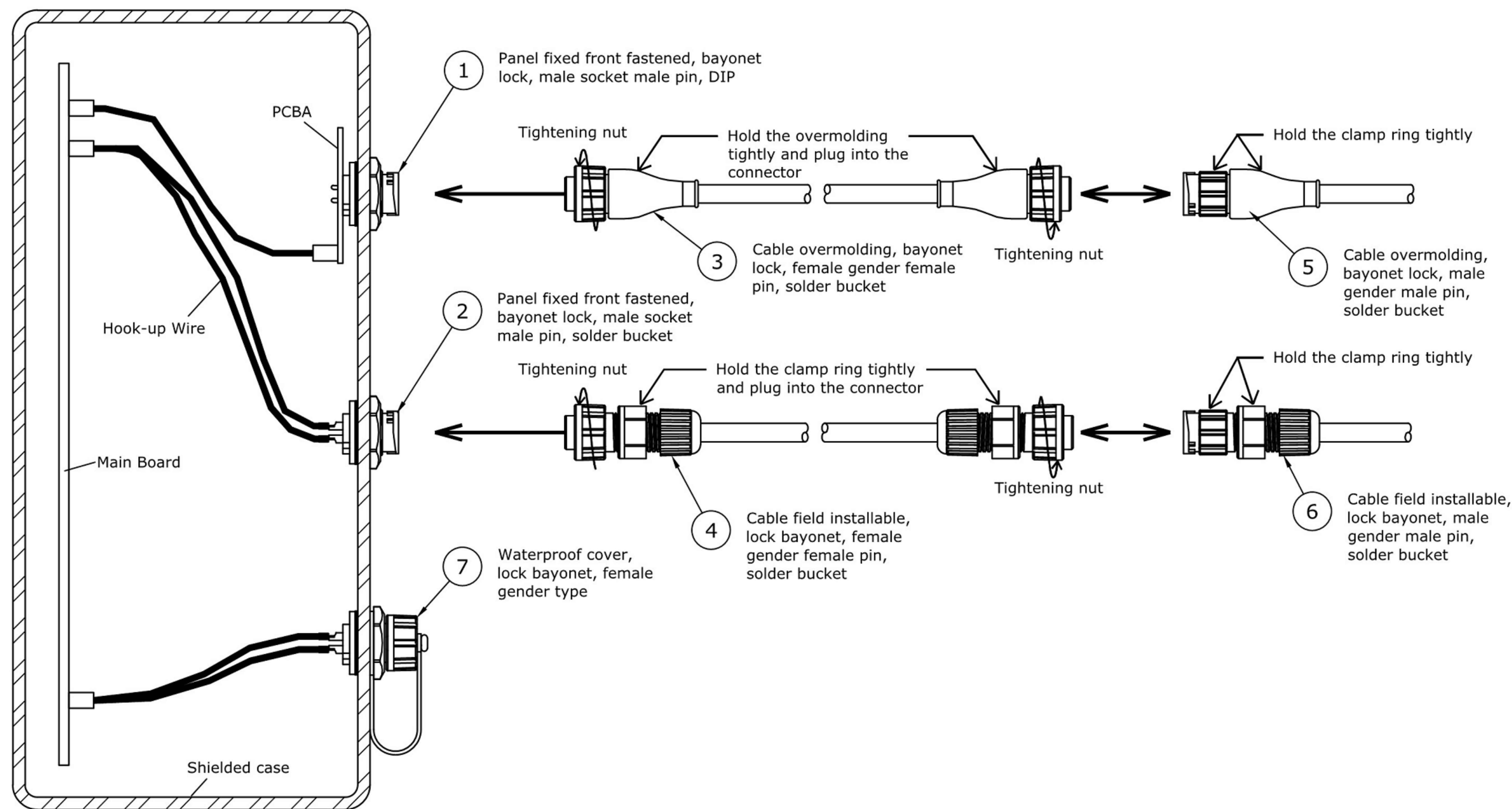

NO.	PARTS	MATERIALS	Q'TY	FINISH	TOLERANCE UNLESS SPECIFIED	ISSUE	DATE	DESCRIPTIONS OF REVISION	APPD.
8									
7									
6					WITHIN 1.5mm : ±0.1mm	A	2012-9-25	初版	ZENQ. CHEN
5					OVER 1.5mm : ±0.2mm	ISSUE	DATE	DESCRIPTIONS OF REVISION	APPD.
4	CONTACT	SUS	1	Ag CLAD	TITLE : 圆形连接器			UNIT : mm	DRWG NO.: XB-227A-MMM0
3	CASE	PPA/BRASS SRTIP	1	BLACK/Ag PLATED	MODEL: Circular Connector			SCALE: 5:1	DWN. JUN. YANG 2012-9-25
2	COVER	STEEL STRIP	1	Ni PLATED	东莞市溪榜电子有限公司 DONG GUAN XI BANG ELECTRONICS CO., LTD.			CHK'D	DONG. PANG 2012-9-25
1	KNOB	PPA	1	BLACK				APPD.	ZENQ. CHEN 2012-9-25