

尺寸
8.3
8.7
9
9.5
10
10.5
11.5
12.5
13.5

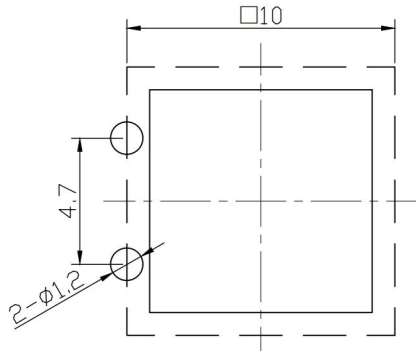

PCB板位置图

SCHEMATIC

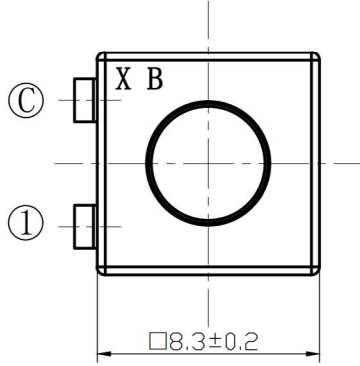
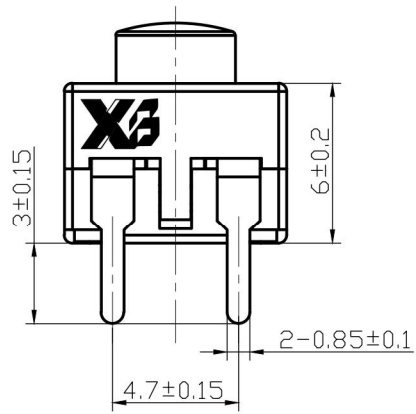
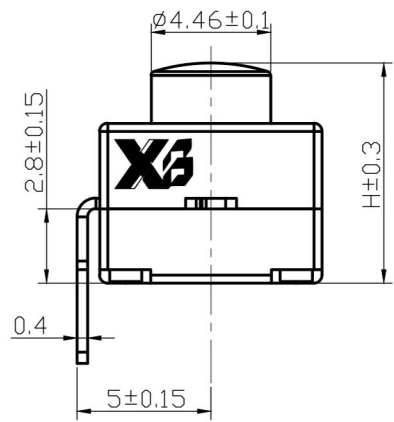
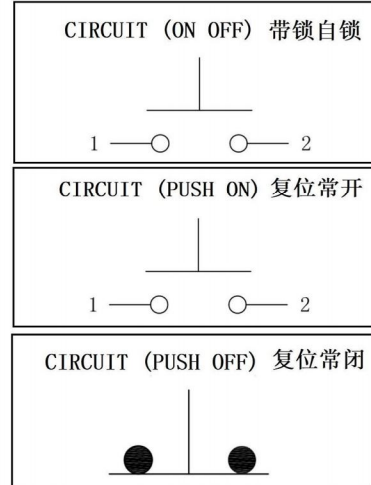

电气原理图

MATERIAL:
 Actuator: SUS ;
 Top Base: SUS;
 Buttom Base: PA66+GF ;
 Terminal: Brass, Silver plated ;
 Nut: Brass, Ni plated .

- 技术要求:**
1. 电气性能
 额定电流/电压: 1A/250VAC;
 接触电阻: $\leq 100m\Omega$;
 绝缘电阻: $\geq 100M\Omega$;
 介电强度: $\geq 500VAC/1min$;
 2. 环境温度: $-25^{\circ}C \sim 75^{\circ}C$;
 3. 相对湿度: $\leq 95\%$ ($40^{\circ}C$) ;
 4. 操作力: $800 \pm 200g$;
 5. 未注公差均按GB / T1804-m级。

The material contained in this drawing is the property of XiBang. Any use other than that specifically authorized by XiBang is prohibited. The above drawing IS subjected to change for improvement without prior notice.



东莞市溪榜电子有限公司
 DONG GUAN XI BANG ELECTRONICS CO., LTD

TITLE : PUHS BUTTON SWITCH
 MODEL : XB-YT-8301N-F

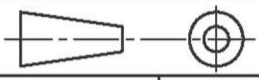

TOLERANCE
 $\leq 1.5mm \pm 0.1$
 $> 1.5mm \pm 0.2$
 $> 10mm \pm 0.3$

ANGLE
 $\pm 2^{\circ}$

UNIT : MM	DWN.	ZENQ. CHEN	DATE	
SCALE : 3 : 1	CHK'D	PENG. GAO	DATE	
VBRSION	01	APPD.	FEI. LONG. HE	DATE

7	SPRING	STEEL WIRE	1	NATURE
6	STEEL BALL	STEEL	1	NATURE
5	BOARD	PHENOLIC RESIN	1	NATURE
4	CONTACT CLIP	PBS STRIP	2	Ag PLATED
3	FRAME	IRON STRIP	1	Ni PLATED
2	TERMINAL	BRASS STRIP	8	Ag PLATED
1	KNOB	POM	1	BLACK
NO.	PART NAME	MATERIAL	QTY.	FINISHING