

ROHS

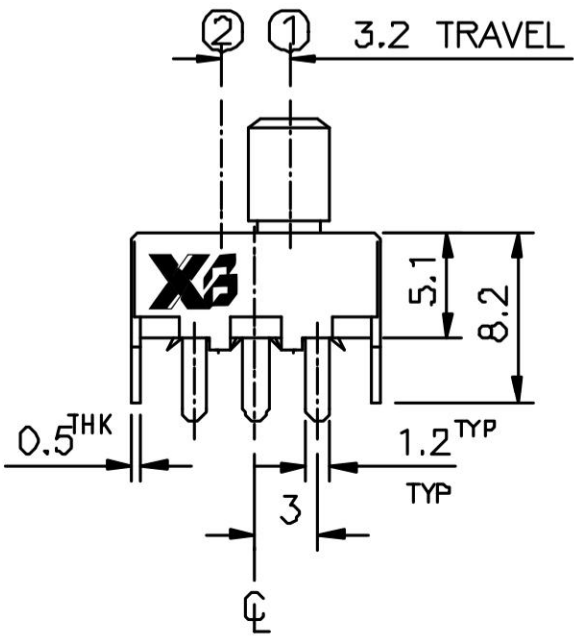

X =

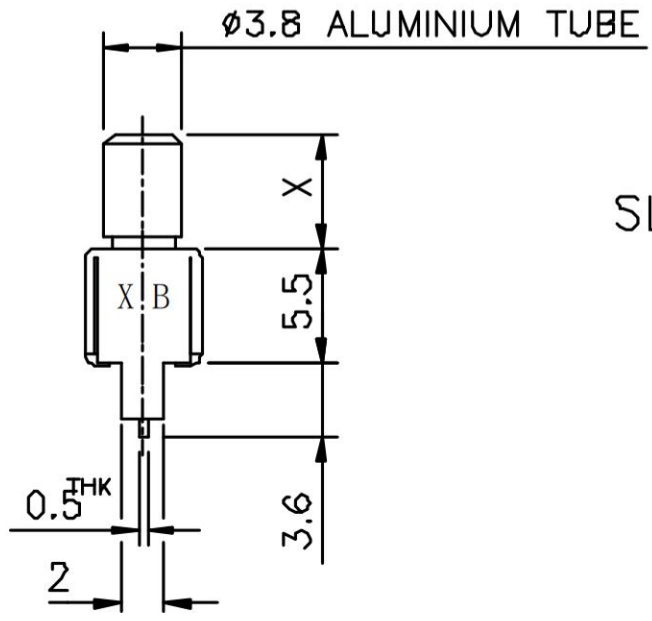

SLIDE SWITCH (SPDT)

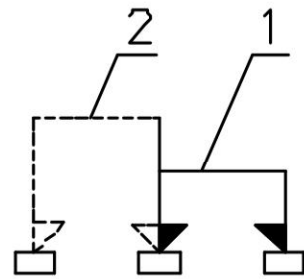

SCHEMATIC

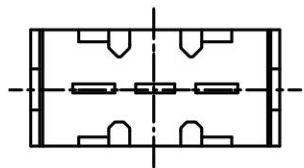
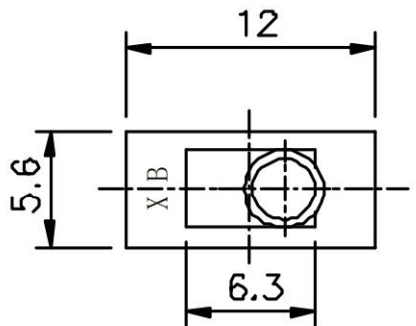

SPECIFICATION

RATING:	DC 50V 0.5A
CONTACT RESISTANCE:	NOT MORE THAN 30mΩ(initial)
INSULATION RESISANCE:	500MΩ AT 500V DC
WITHSTAND VOLTAGE:	AC 500V FOR 1 MIN
OPERATION FORCE:	200±100g
SWITCHING LIFE:	10000 Cycles(15-18c/m unloading)

The material contained in this drawing is the property of XiBang. Any use other than that specifically authorized by XiBang is prohibited. The above drawing IS subjected to change for improvement without prior notice.



东莞市溪榜电子有限公司
DONG GUAN XI BANG ELECTRONICS CO., LTD

TITLE : XB SLIDE SWITCH
MODEL : XB-SS-12F22X



TOLERANCE
<=1.5mm±0.1
> 1.5mm±0.2
>=10mm±0.3

ANGLE
±2°

UNIT :	MM	DWN.	ZENQ. CHEN	DATE	
SCALE :	3 : 1	CHK'D	PENG. GAO	DATE	
VBRSION	01	APPD.	FEI. LONG. HE	DATE	

7	SPRING	STEEL WIRE	1	NATURE
6	STEEL BALL	STEEL	1	NATURE
5	BOARD	PHENOLIC RESIN	1	NATURE
4	CONTACT CLIP	PBS STRIP	2	Ag PLATED
3	FRAME	IRON STRIP	1	Ni PLATED
2	TERMINAL	BRASS STRIP	8	Ag PLATED
1	KNOB	POM	1	BLACK
NO.	PART NAME	MATERIAL	QTY	FINISHING