

ROHS

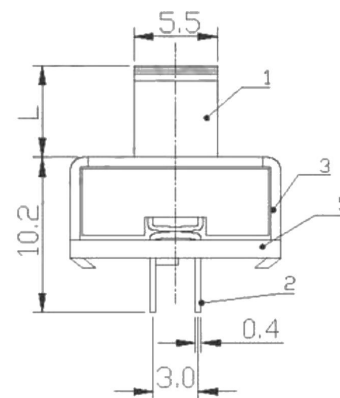

L: 2-15

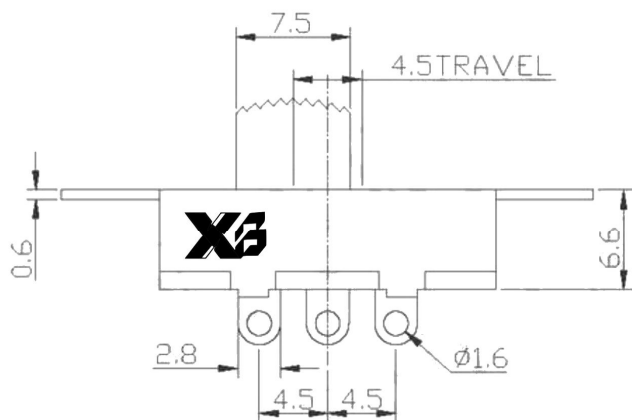
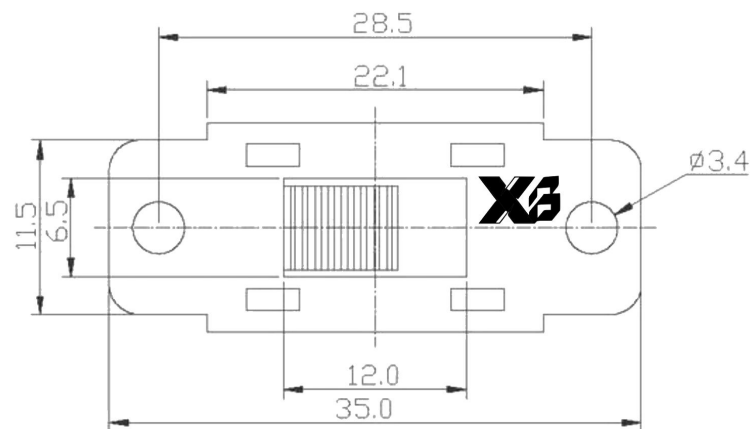
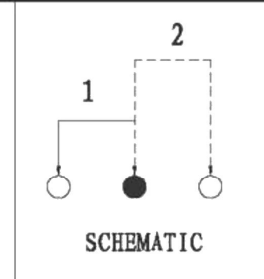

Switch Connector

东莞市溪榜电子有限公司
DONG GUAN XI BANG ELECTRONICS CO.,LTD

TITLE : VERTICAL SLIDE SWITCH

MODEL : SS12I05 (W009)



TOLERANCE
$\le 5.0\text{mm} \pm 0.1$
> 5.0mm ± 0.2

ANGLE TOL
 $\pm 2^\circ$

UNIT : MM	DWN.	DATE
SCALE : 2 : 1	CHK'D	DATE
VERSION	01	APPD.
		DATE

NO.	PART NAME	MATERIAL	QTY	FINISHING
6	SPRING	STEEL WIRE	1	NATURE
5	BOARD	PHENOLIC RESIN	1	BLACK
4	CONTACT CLIP	COPPER	1	Ag PLATED
3	FRAME	IRON STRIP	1	ZN PLATED
2	EARTH TERMINAL	BRASS STRIP	3	Ag PLATED
1	KNOB	POM	1	BLACK