

# ROHS

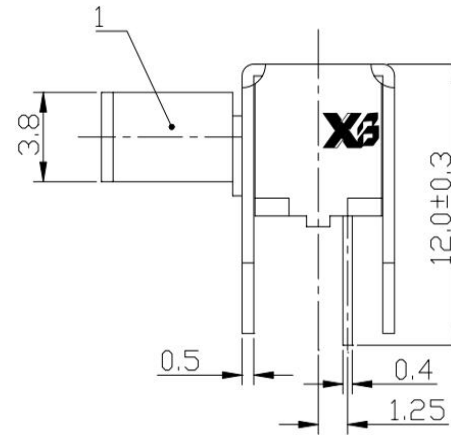

L=2~15

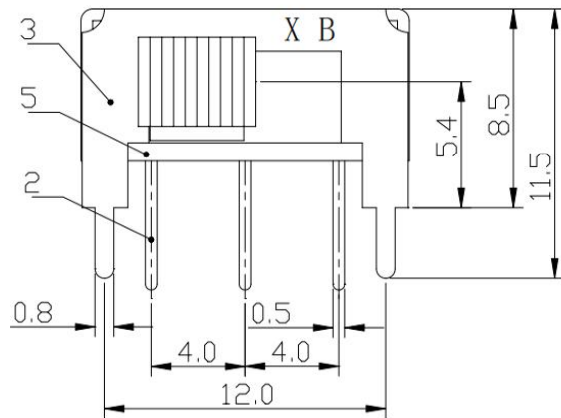
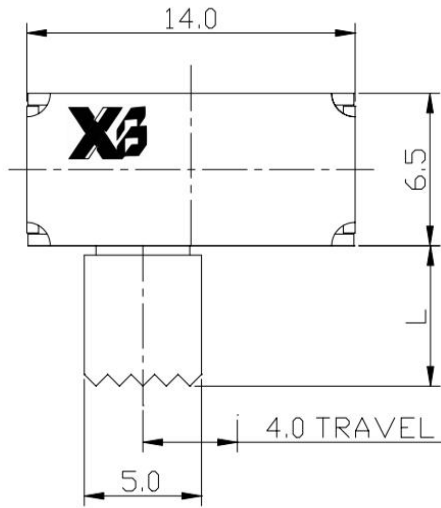
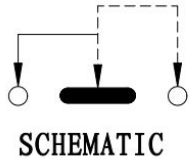

东莞市溪榜电子有限公司  
DONG GUAN XI BANG ELECTRONICS CO.,LTD

TITLE : HORIZONTAL SLIDE SWITCH  
MODEL : SK12H09-GFC (G)

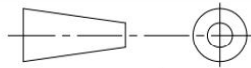

UNIT : MM	DWN.	DATE	2008-08-27	TOLERANCE <=5mm ±0.1 > 5mm ±0.2 >=10mm ±0.3	ANGLE ±2°
SCALE : 3 : 1	CHK'D	DATE	2008-08-27		
VERSION 01	APPD.	DATE	2008-08-27		

7	SPRING	STEEL STRIP	1	NATURE
6	STEEL BALL	STEEL	1	NATURE
5	BOARD	PHENOLIC RESIN	1	NATURE
4	CONTACT CLIP	PBS STRIP	1	NATURE
3	FRAME	IRON STRIP	1	Ni PLATED
2	TERMINAL	BRASS STRIP	3	Ag PLATED
1	KNOB	POM	1	BLACK
NO.	PART NAME	MATERIAL	QTY	FINISHING