

REV.	DESCRIPTION	DATE
A	RELEASE	Feb.28, 2019
B	ADD PACKING	Apr.20, 2019
C	MODIFY DIM	May.13, 2019
D	MODIFY DIM	Jun.06, 2019

MATERIALS:

- HOUSING: LCP (UL94V-0),BLACK.
- TERMINAL: COPPER ALLOY, T=0.20mm.
PLATING: GOLD PLATED.
- SHELL: STAINLESS STEEL, T=0.30mm;
PLATING: NICKEL PLATED OVERALL.

SPECIFICATION

- CURRENT RATING : 0.5A. MAX.
- DIELECTRIC WITHSTANDING VOLTAGE :
500V AC R.M.S. FOR ONE MINUTE.
- INSULATION RESISTANCE : 100MΩ MIN.AT 500V DC.
- CONTACT RESISTANCE : 30mΩ MAX.
- OPERATING TEMPERATURE : -25°C TO +85°C.
- DURABILITY : 10000 CYCLES.
- MATING FORCE : 4.5kgf MAX.
- UNMATING FORCE : 1.0kgf MIN.

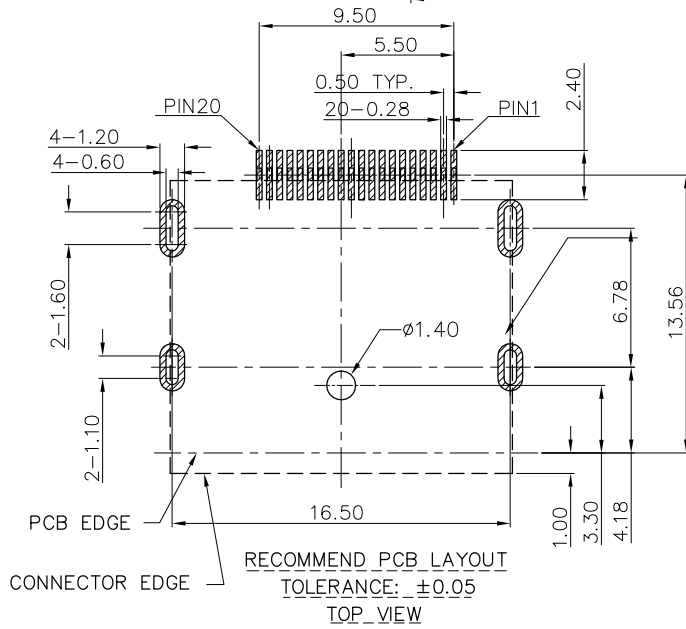
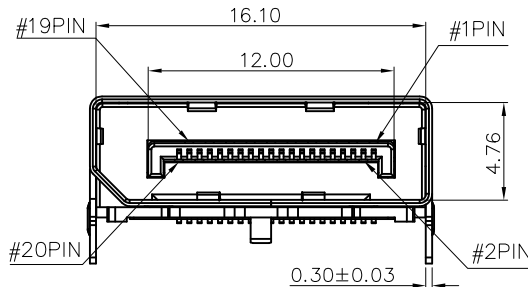
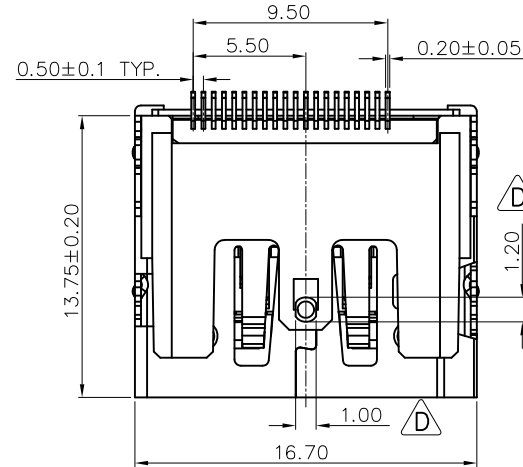
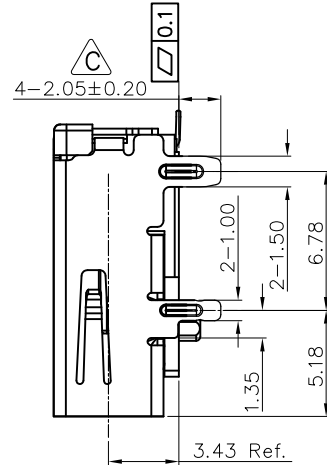
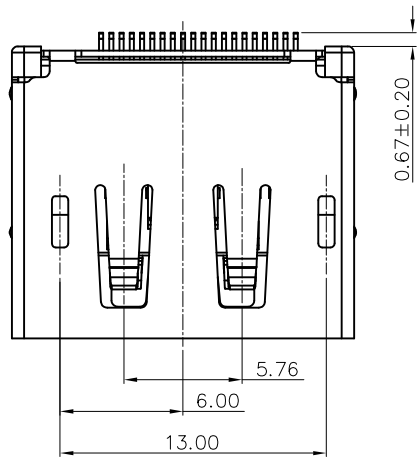
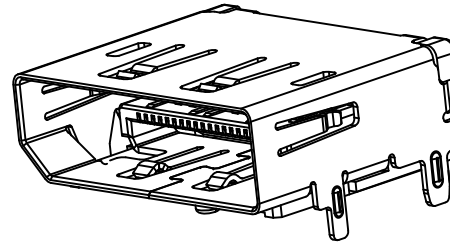
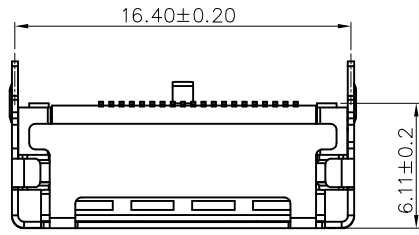

TOLERANCE .0=±0.25 .00=±0.15 .000=±0.05 ANG.=±3°		DRAWER Chen		NAME DISPLAY PORT R/A SMT TYPE. FEMALE	
		CHECK Stony			
		APP'D Stony		DRAW NO.	
		PRODUCT SPEC. —			
UNITS : mm		SCALE NONE	SIZE A4	SHEET 1 OF 2	
		REVISION D			

REV.	DESCRIPTION	DATE
A	RELEASE	Feb.28, 2019
B	ADD PACKING	Apr.20, 2019
C	MODIFY DIM	May.13, 2019
D	MODIFY DIM	Jun.06, 2019

B

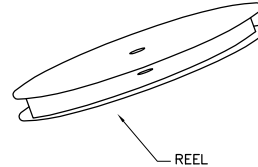
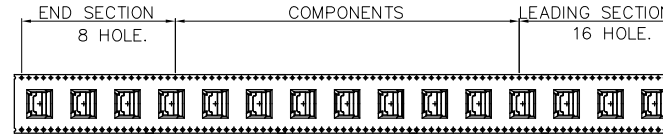
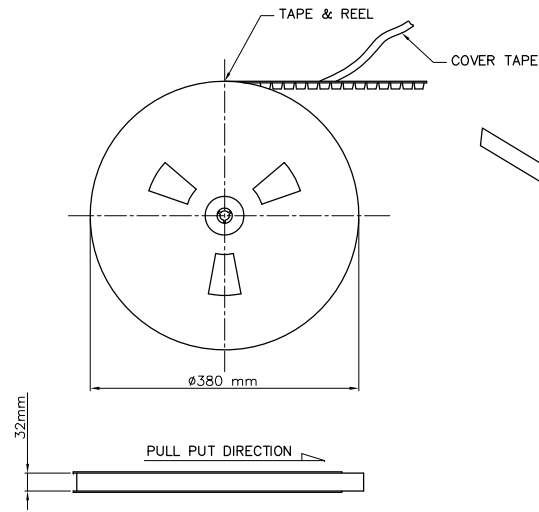

TAPE & PACKAGE :

MATERIAL :

1. CARRIER TAPE : PS
2. COVER TAPE: PE
3. REEL : PS

QUANTITY:

1. 350 PCS/REEL
2. 10 REEL/CARTON: 3500PCS

DIMENSION :

- REEL SIZE :
 DIA=380.0mm, W=32.0mm
 CARTON :
 L=400mm, W=400mm, H=400mm

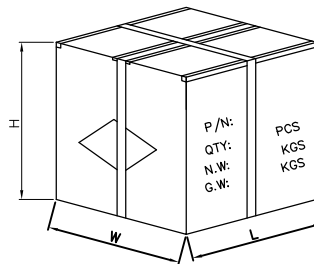
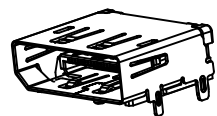
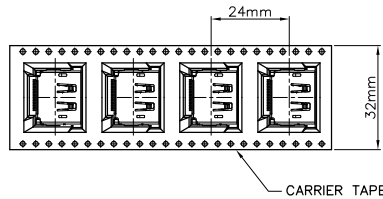
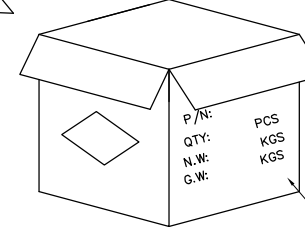
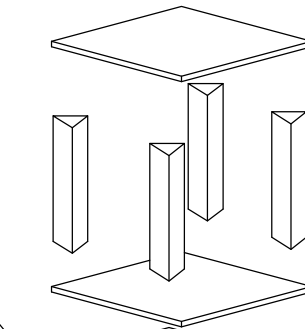
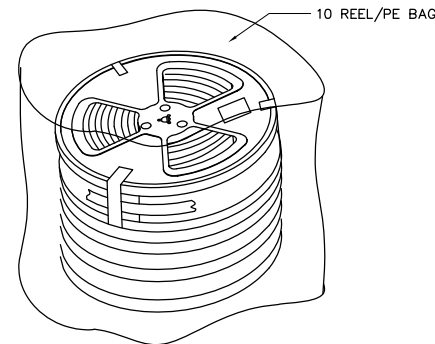
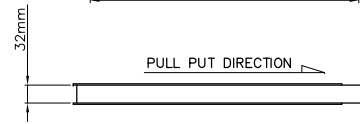

<p>TOLERANCE</p> <p>.0=±0.25</p> <p>.00=±0.15</p> <p>.000=±0.05</p> <p>ANG.=±3°</p>	<p>DRAWER</p> <p><i>Shen</i></p>	<p>NAME</p> <p>DISPLAY PORT R/A SMT TYPE. FEMALE</p>
	<p>CHECK</p> <p><i>Sheny</i></p>	
<p></p> <p>UNITS : mm</p>	<p>PRODUCT SPEC.</p> <p>—</p>	<p>DRAW NO.</p>
<p>SCALE NONE</p>	<p>SIZE A4</p>	<p>SHEET 2 OF 2</p>
	<p>REV. D</p>	

REV.	DESCRIPTION	DATE
A	RELEASE	Feb.28, 2019
B	ADD PACKING	Apr.20, 2019
C	MODIFY DIM	May.13, 2019
D	MODIFY DIM	Jun.06, 2019

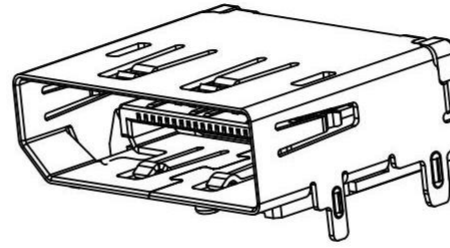
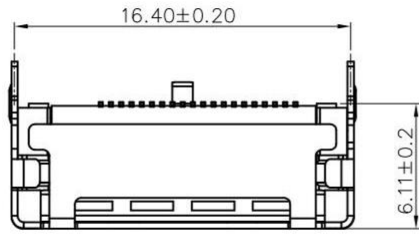

MATERIALS:

- HOUSING: LCP (UL94V-0),BLACK.
- TERMINAL: COPPER ALLOY, T=0.20mm.
PLATING: GOLD PLATED.
- SHELL: STAINLESS STEEL, T=0.30mm;
PLATING: NICKEL PLATED OVERALL.

SPECIFICATION

- CURRENT RATING : 0.5A. MAX.
- DIELECTRIC WITHSTANDING VOLTAGE :
500V AC R.M.S. FOR ONE MINUTE.
- INSULATION RESISTANCE : 100MΩ MIN.AT 500V DC.
- CONTACT RESISTANCE : 30mΩ MAX.
- OPERATING TEMPERATURE : -25°C TO +85°C.
- DURABILITY : 10000 CYCLES.
- MATING FORCE : 4.5kgf MAX.
- UNMATING FORCE : 1.0kgf MIN.

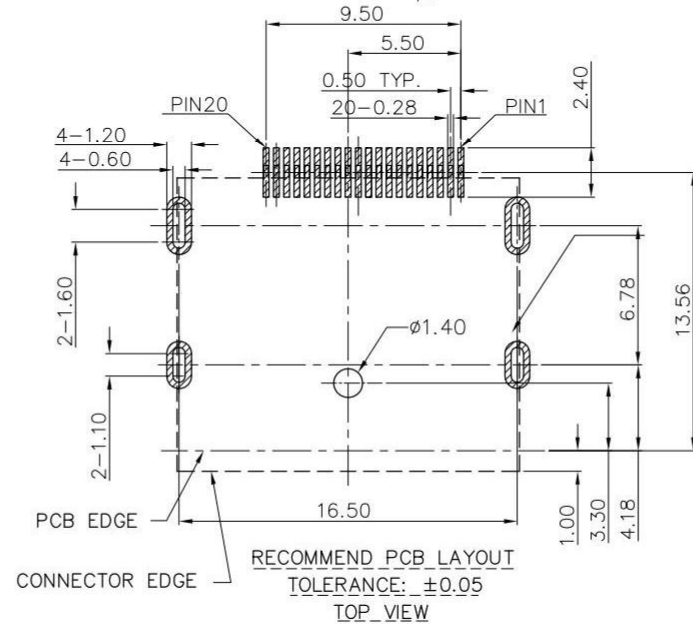
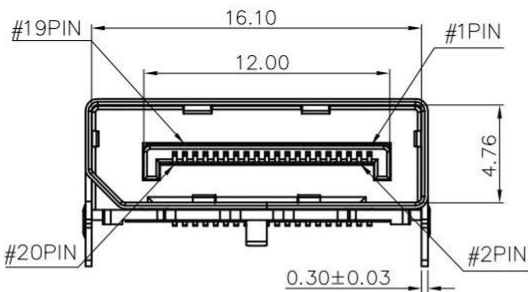
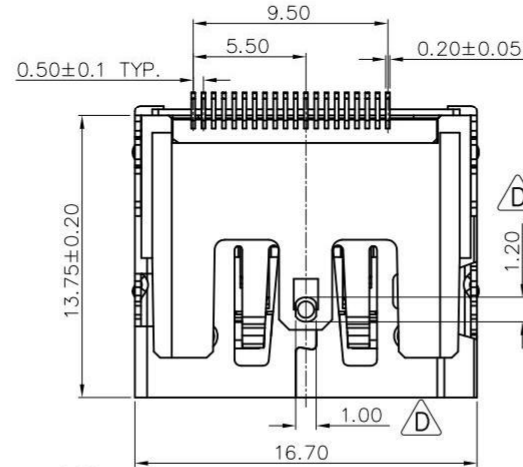
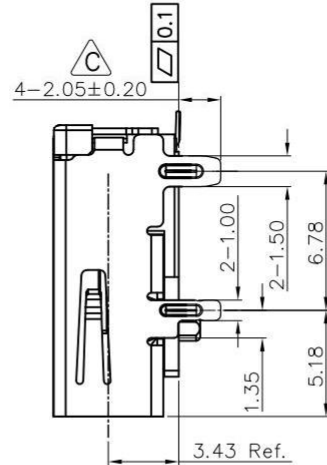
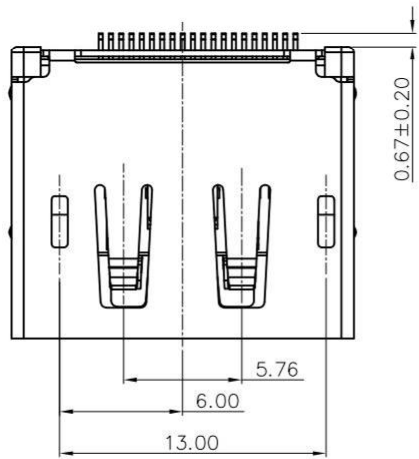

TOLERANCE

.0=±0.25
.00=±0.15
.000=±0.05
ANG.=±3°

XB 东莞市溪榜电子有限公司
DONG GUAN XI BANG ELECTRONICS CO., LTD.

APP'D <i>Shony</i>	NAME DISPLAY PORT R/A SMT TYPE. FEMALE
PRODUCT SPEC. —	DRAW NO.

UNITS : mm

SCALE NONE	SIZE A4	SHEET 1 OF 2	REV. D
---------------	------------	-----------------	-----------

REV.	DESCRIPTION	DATE
A	RELEASE	Feb.28, 2019
B	ADD PACKING	Apr.20, 2019
C	MODIFY DIM	May.13, 2019
D	MODIFY DIM	Jun.06, 2019

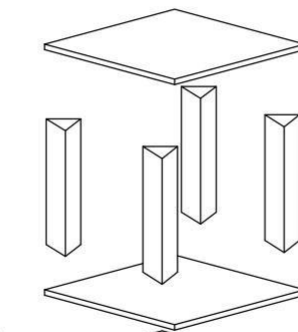
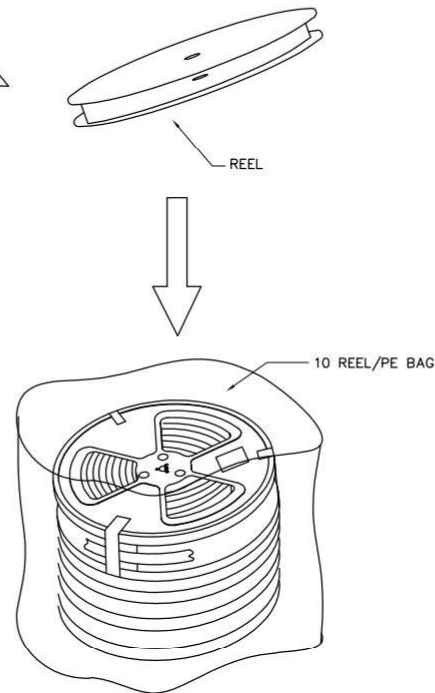
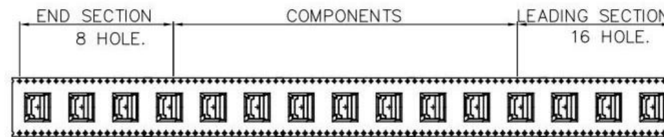
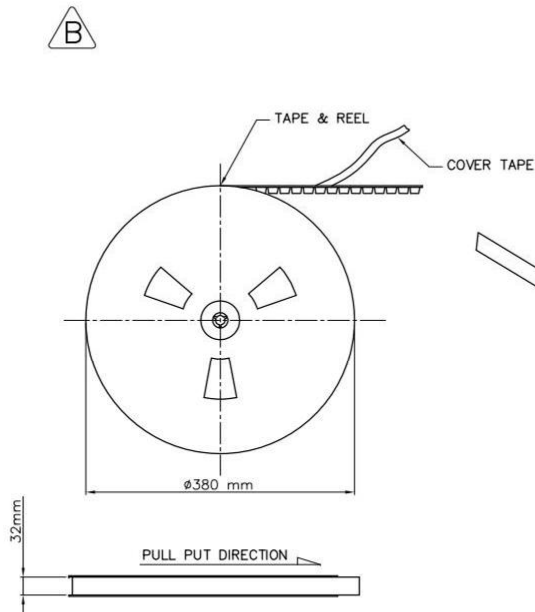

TAPE & PACKAGE :

MATERIAL :

1. CARRIER TAPE : PS
2. COVER TAPE: PE
3. REEL : PS

QUANTITY:

1. 350 PCS/REEL
2. 10 REEL/CARTON: 3500PCS

DIMENSION :

REEL SIZE :

DIA=380.0mm, W=32.0mm

CARTON :

L=400mm, W=400mm, H=400mm

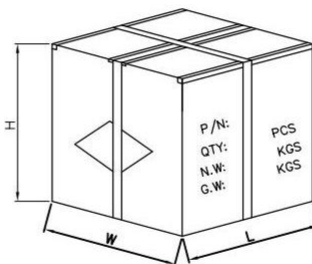
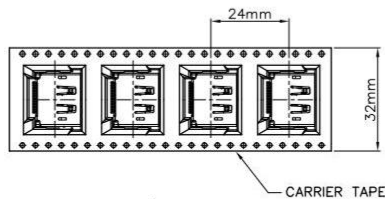

TOLERANCE	
.0=±0.25	
.00=±0.15	
.000=±0.05	
ANG.=±3'	

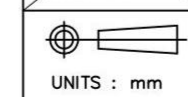

SCALE	SIZE
NONE	A4

XB 东莞市溪榜电子有限公司
DONG GUAN XI BANG ELECTRONICS CO., LTD.

APP'D <i>Slony</i>	NAME DISPLAY PORT R/A SMT TYPE. FEMALE
PRODUCT SPEC. —	DRAW NO.

SHEET	REV.
2 OF 2	D