

SUA-110V2x-x-S236

SHELL :	Color :
Blank : Copper Alloy	Black : B
I : SPCC	White : W

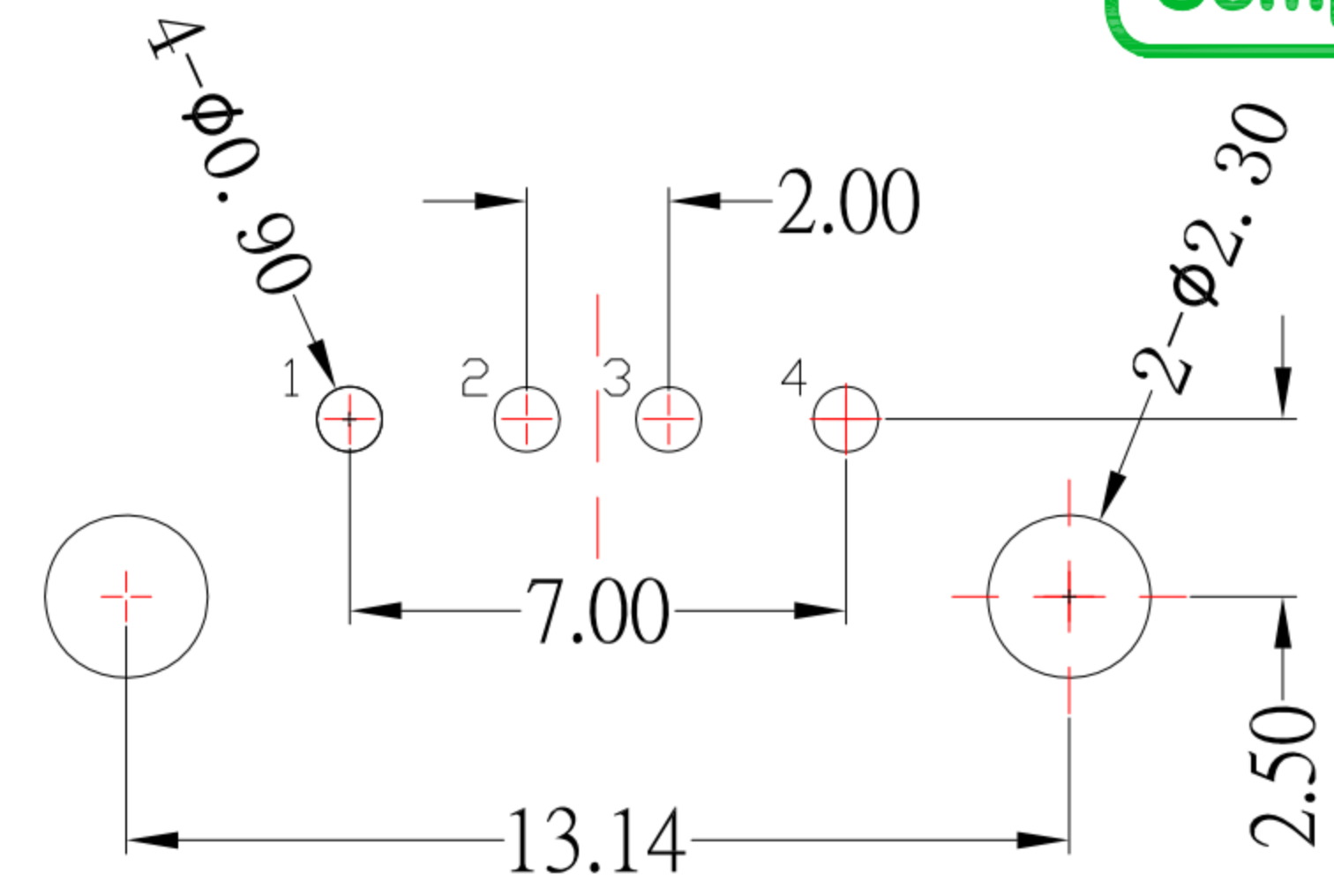

P.C.B LAYOUT MOUNTING PATTERN

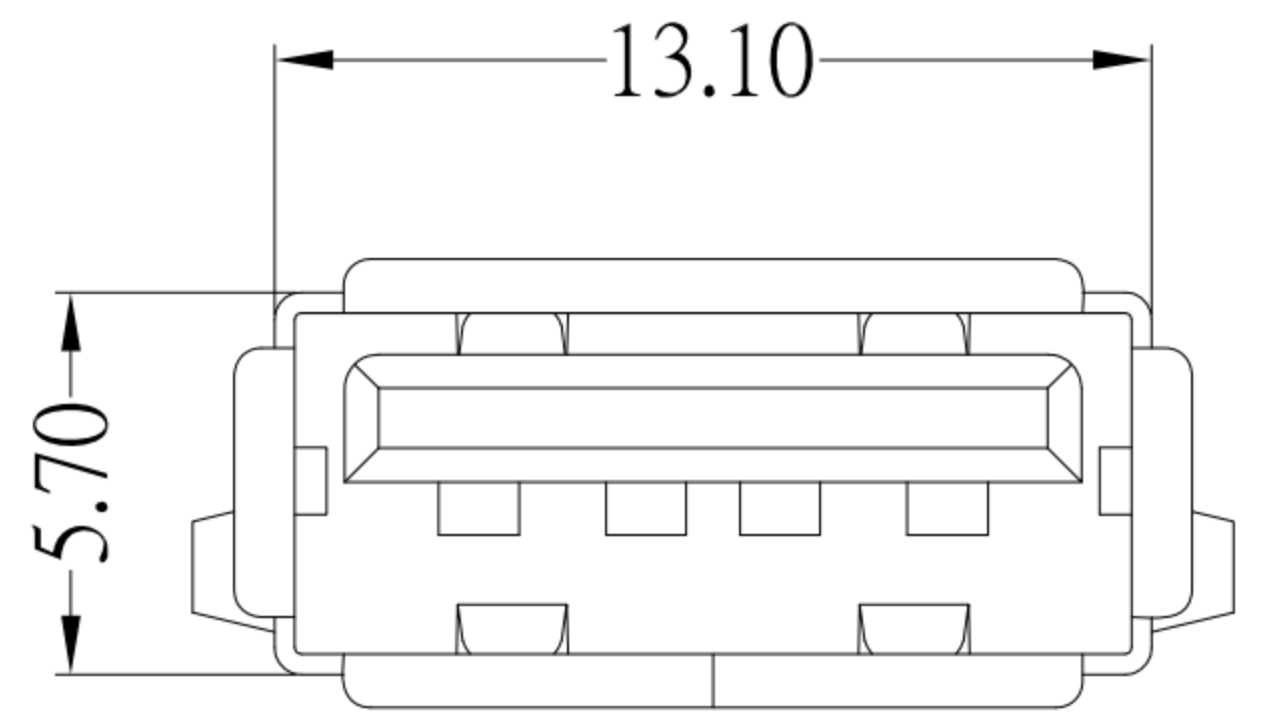
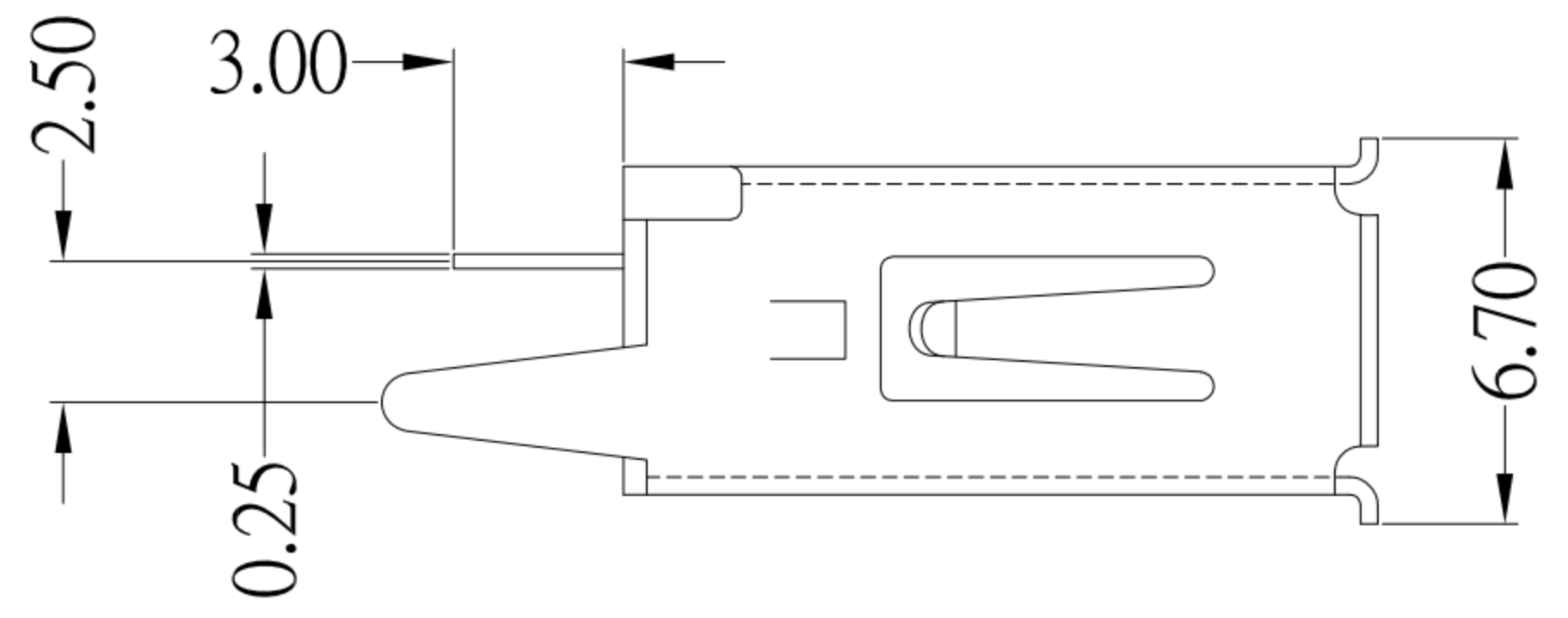

SPECIFICATIONS

Electrical:

- 1.Current Rating: 1.5A
- 2.Voltage Rating: 30 VDC
- 3.Contact Resistance: 30 mΩ Max
- 4.Dielectric Withstanding Voltage: 500 V AC For 1 min
- 5.Insulation Resistance: 1,000 MΩ Min

Mechanical:

- 1.Connector Mate and Unmate Force
 - 1.1 Mate force: 3.57 kgf (Max)
 - 1.2 Unmate force: 1.02 kgf (Min)

Material:

- 1.Housing: PBT
- 2.Contact: Copper Alloy
- 3.Shell: Copper Alloy / Spcc

Finish:

- 1.Contact: Plated Gold in Mating Area ;
Tin Plated on Solder Balls
Nickel under plated overall
- 2.Shell: Nickel under Plated surface layer

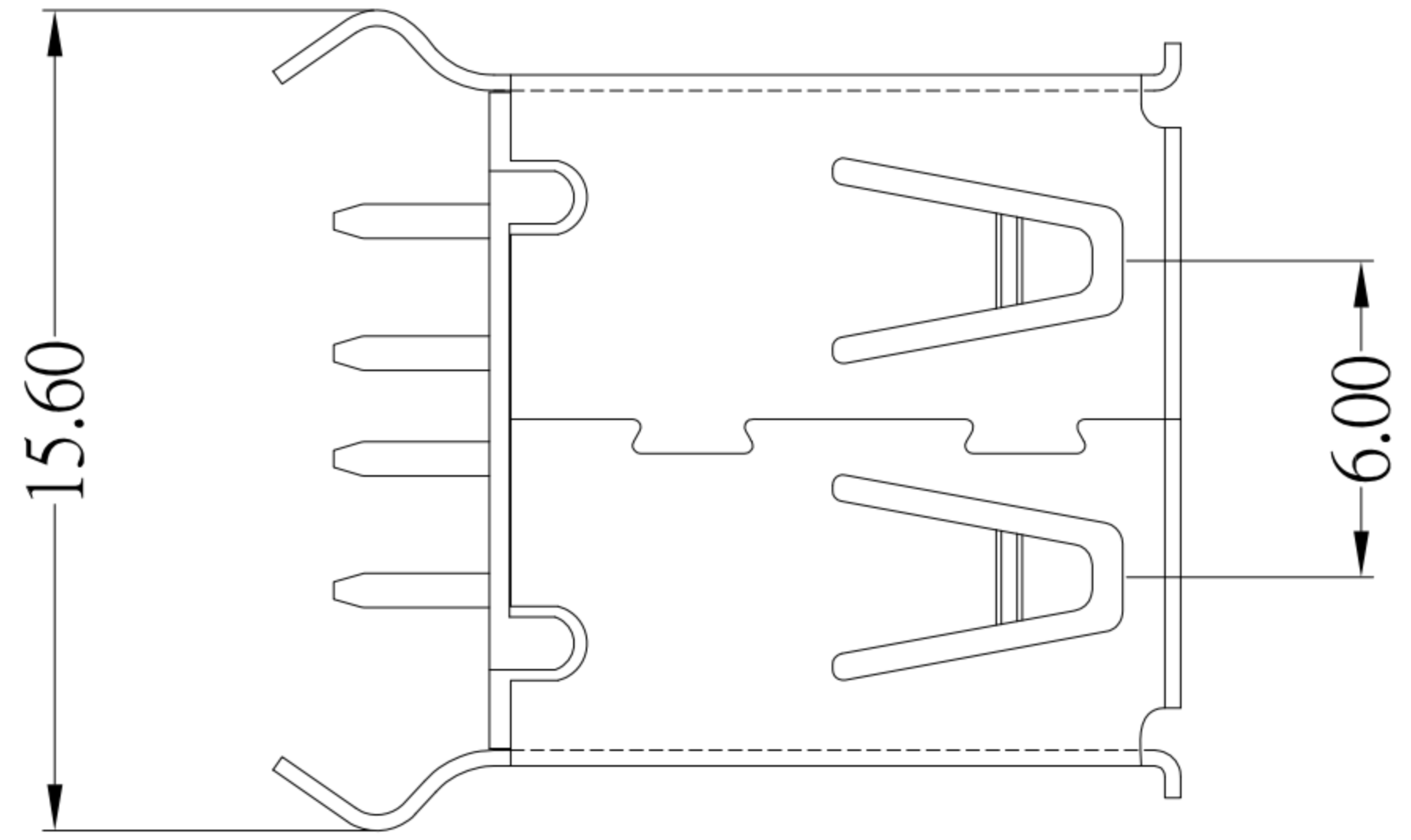

TOLERANCE UNLESS OTHERWISE STATED :	Up to 5 ±0.2	3RD. ANGEL'S	UNITS	MM
	Above 5 ~ 15 ±0.3			
	Above 15 ~ 30 ±0.4			
	Above 30 ~ 50 ±0.5			
	Angle ±0.3°			

DRAWN BY:	DATE	MAT'L	TITLE	CONNECTOR
Jack Lu	09/09/20			
CHECKED BY:	DATE	FINISH	MODLE	USB AF 直立式 L13.1 卷邊, 彎腳
Jacky Chen	09/09/20			
APPROVED BY:	DATE	SCALE	DWG NO.	SUA-110V2x-x-S236
Tony Kao	09/09/20	1 : 1		
		SHEET NO.	PART NO.	SUA-110V2x-x-S236
		1 of 1		

ITEM NO.	DESCRIPTION	DRAWN	DATE