

SUA-110H21Ax-x-S236

SHELL :	COLOR :
Blank : BRASS	Black: B
I : SPCC	White : W

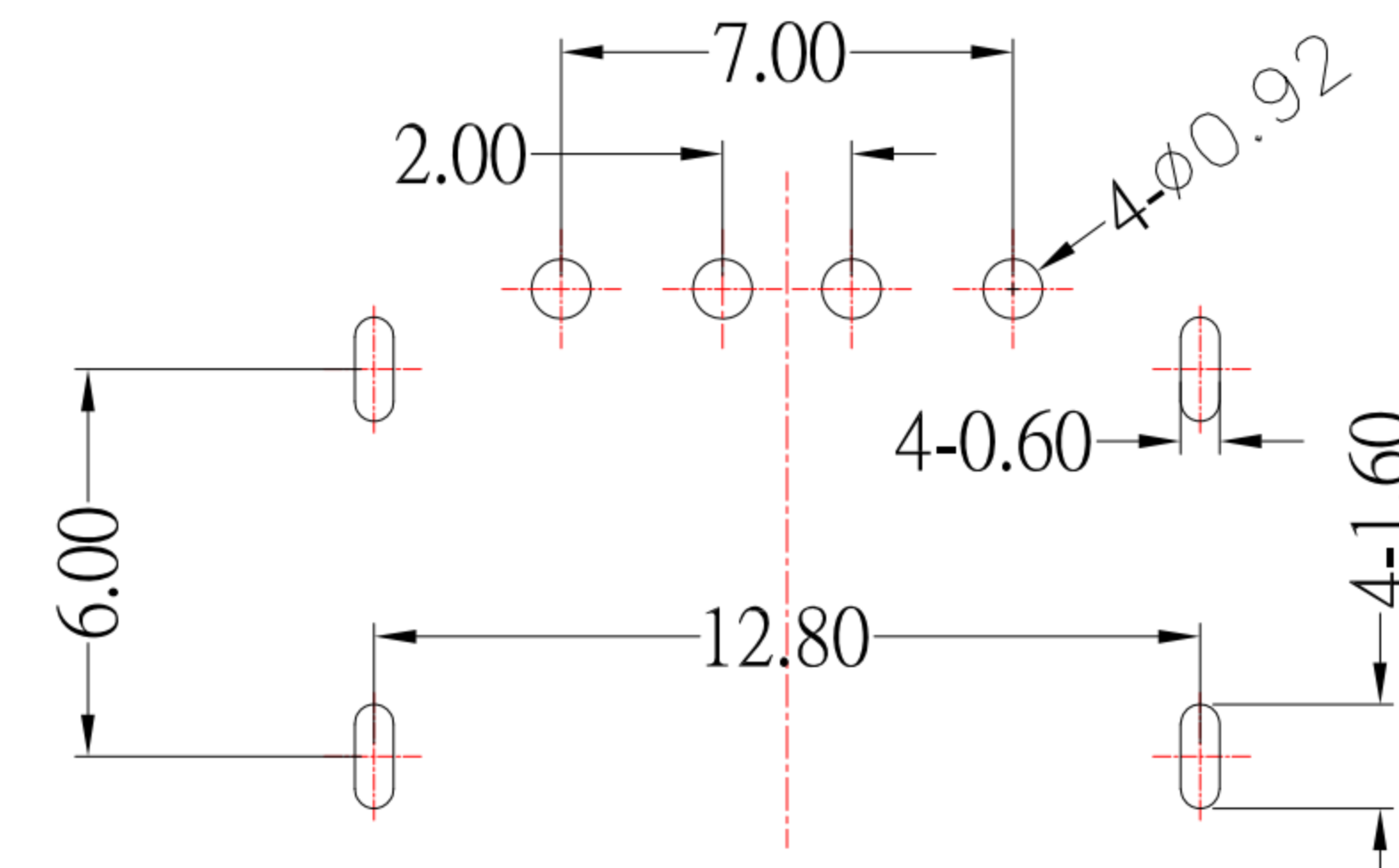

P.C.B LAYOUT MOUNTING PATTERN

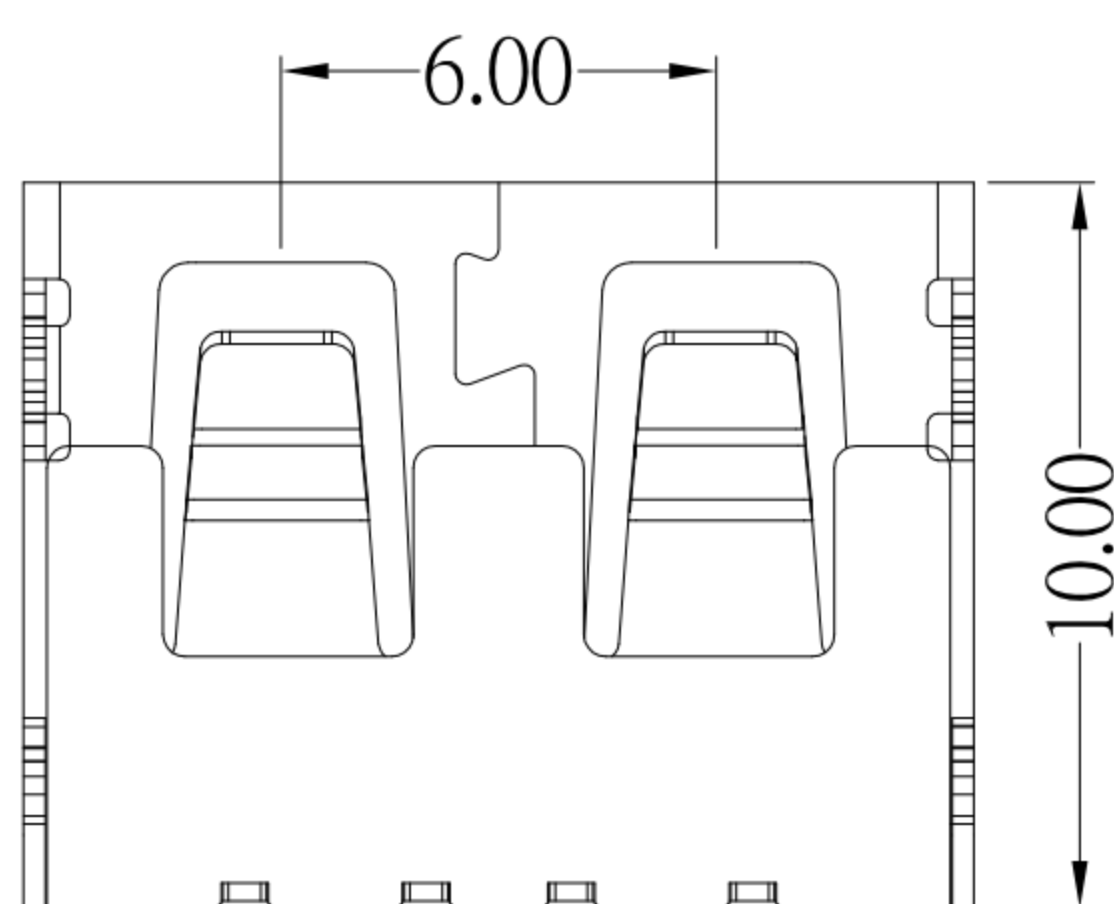
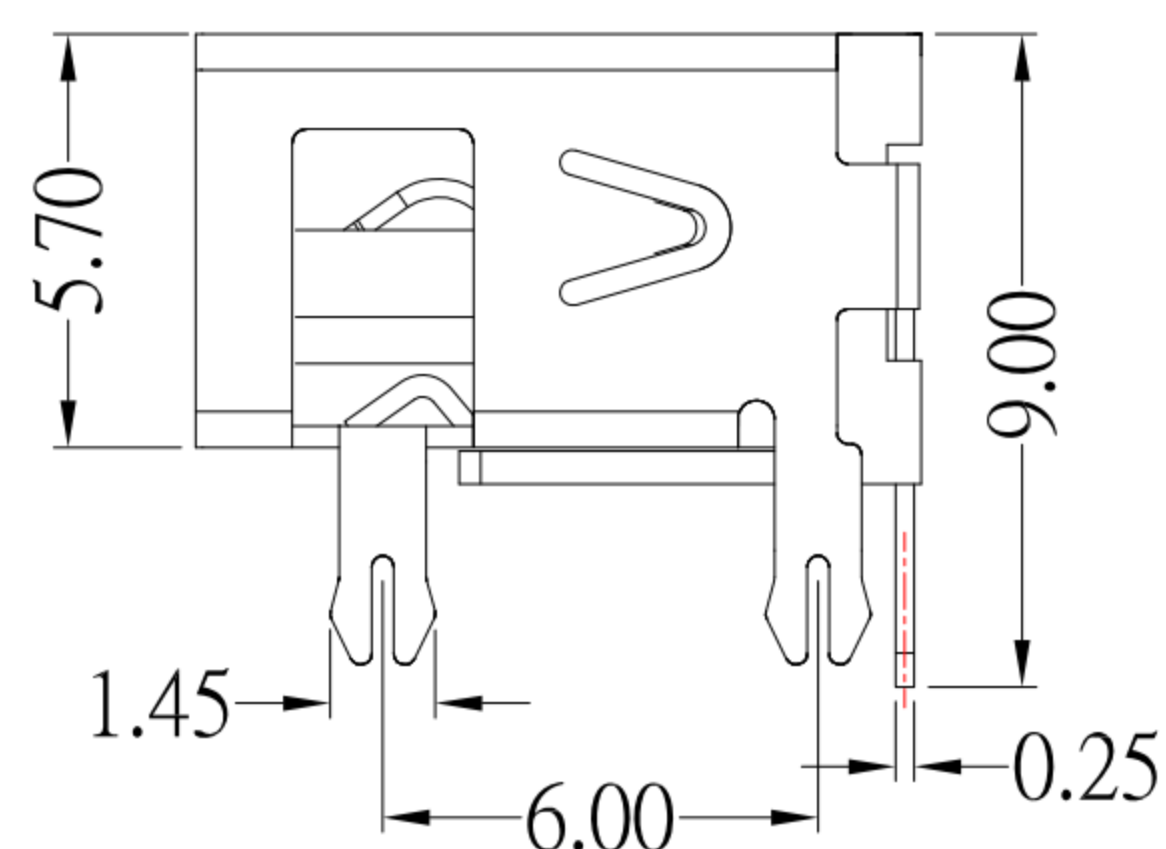
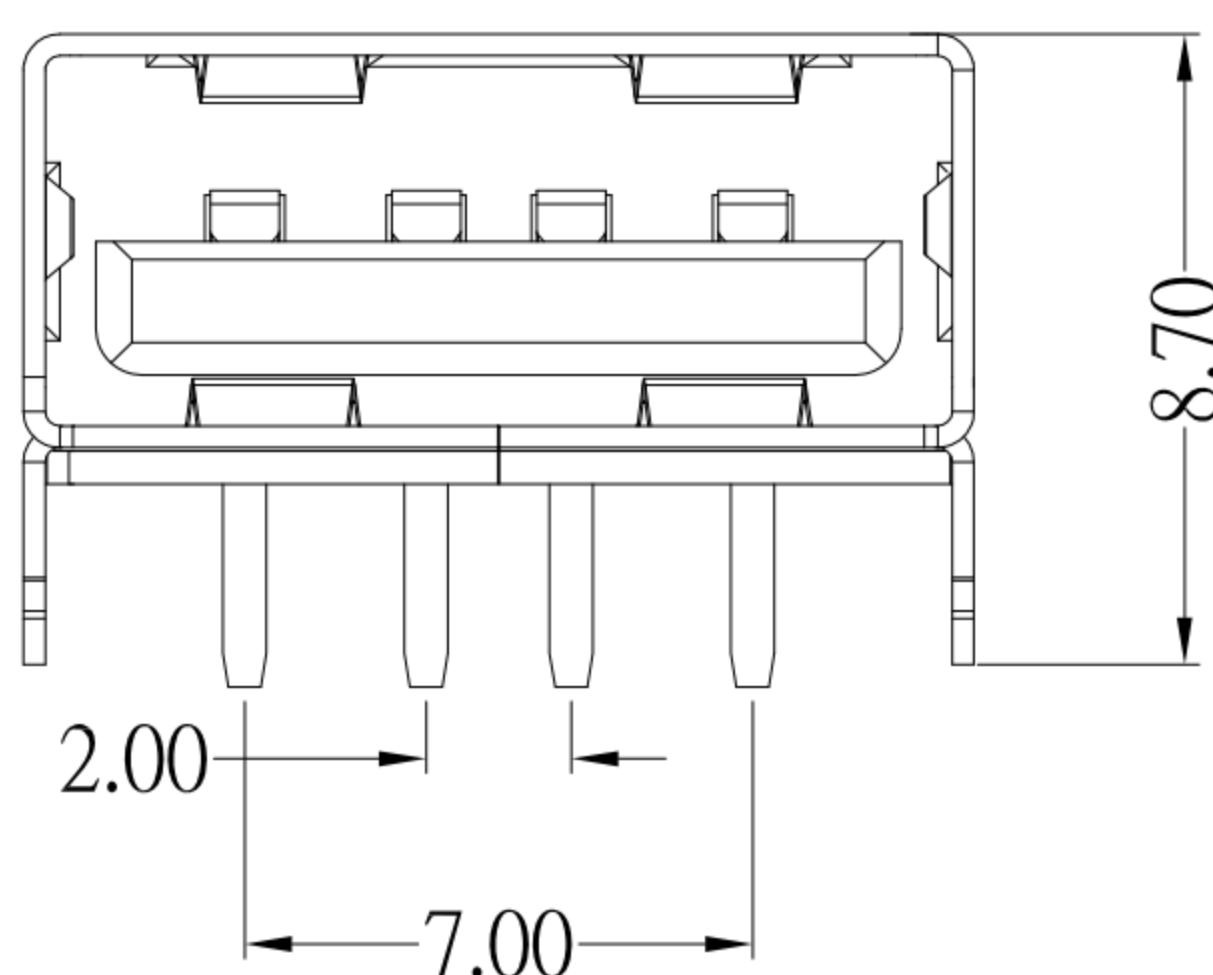

SPECIFICATIONS

Electrical:

- Contact Resistance: 30 mΩ Max
- Dielectric Withstanding Voltage: 500 V AC / 1 minute
- Insulation Resistance: 1,000 MΩ Min

Mechanical:

- Connector Mate and Unmate Force
  - Mate force: 35 N (Max)
  - Unmate force: 10N (Min)

Material:

- Housing: PBT
- Contact: Copper Alloy
- Shell: Brass / Spcc

Finish:

- Contact: Plated Gold in Mating Area ;  
Tin Plated on Solder Balls ;  
Nickel under plated overall
- Shell: Nickel under Plated surface layer



TOLERANCE UNLESS OTHERWISE STATED :	Up to 5 ±0.2	3RD. ANGEL'S	UNITS	MM
	Above 5 ~ 15 ±0.3			
	Above 15 ~ 30 ±0.4			
	Above 30 ~ 50 ±0.5			
	Angle ±0.3°			

DRAWN BY:	DATE	MAT'L	TITLE	CONNECTOR
Jack Lu	06/24/20			
CHECKED BY:	DATE	FINISH	MODLE	USB AF 短體 10.0 無捲邊 4腳 反向
Jacky Chen	06/24/20			
APPROVED BY:	DATE	SCALE	DWG NO.	SUA-110H21Ax-x-S236
Tony Kao	06/24/20	1 : 1		
		SHEET NO.	PART NO.	SUA-110H21Ax-x-S236
		1 of 1		

ITEM NO.	DESCRIPTION	DRAWN	DATE