

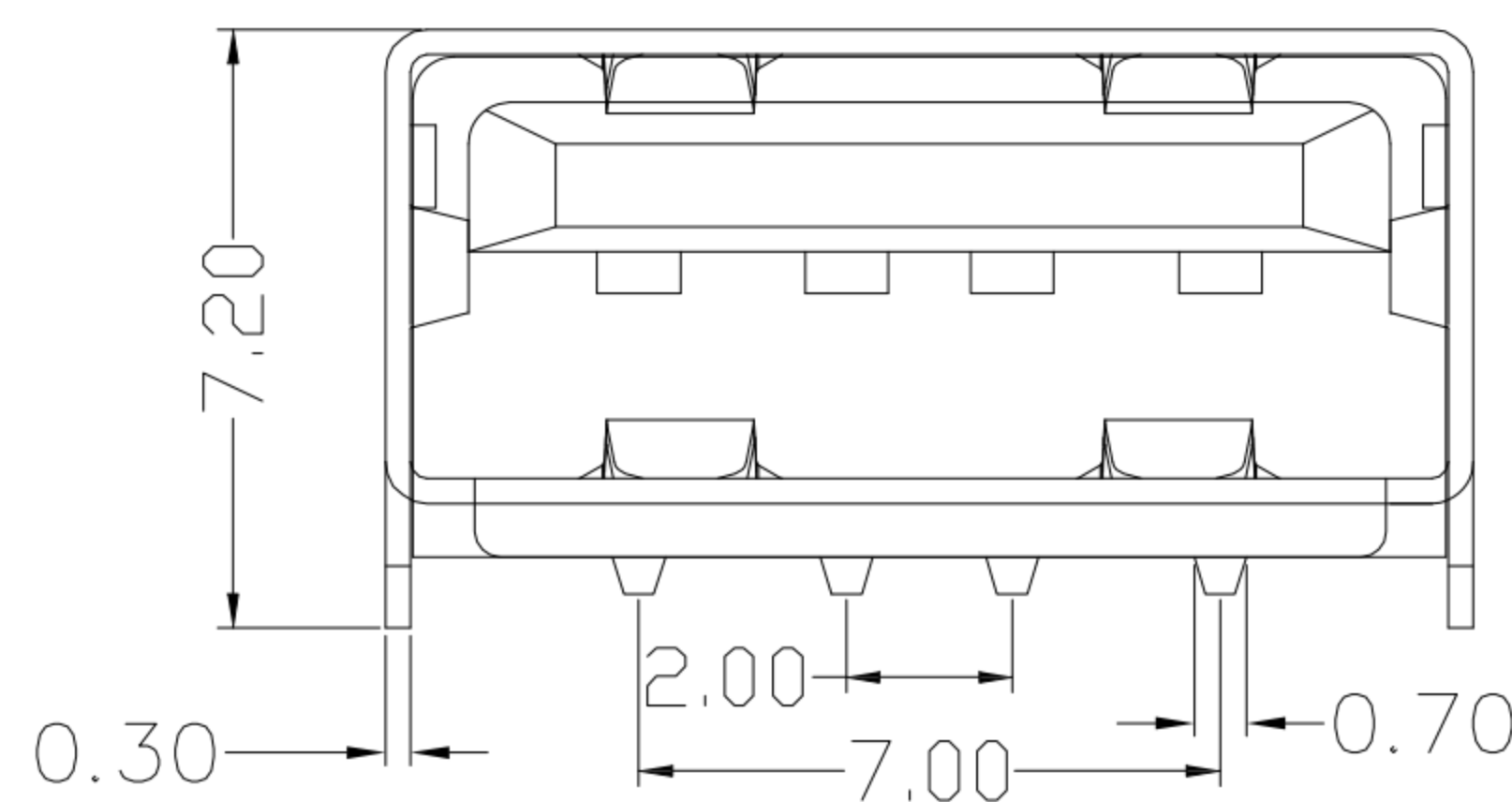

SUA-110E9x-x-S235

Shell Material : _____
 Blank : Phosphor Bronze
 I : SPCC

Color :
 White : W
 Black : B

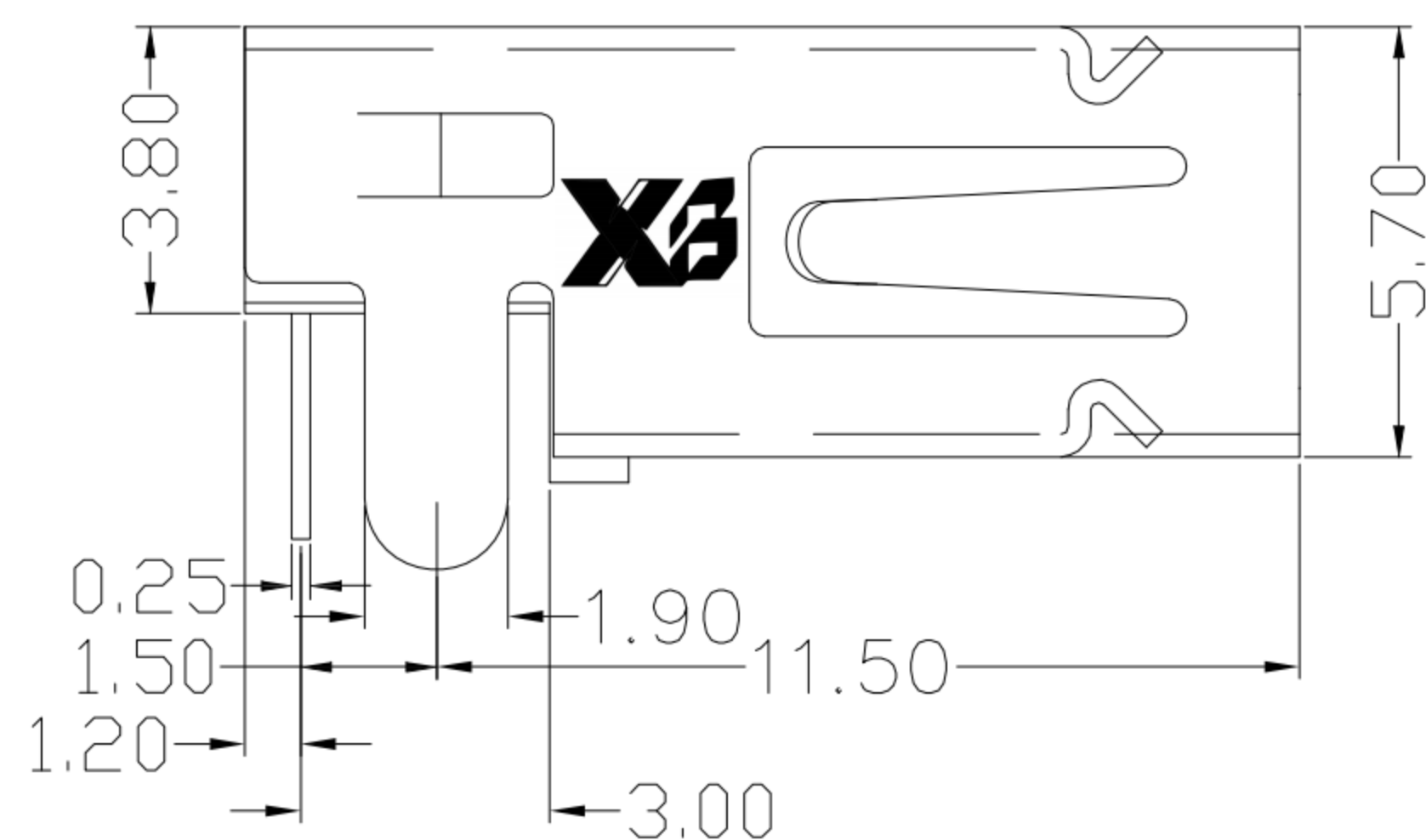

SPECIFICATIONS

Electrical:

1. Voltage Current Rating: 1.5 AMP, 30VAC
2. Contact Resistance: 30 mΩ Max
3. Insulation Resistance: 1,000 MΩ Min
4. Dielectric Withstanding Voltage: 500 V AC
5. Operating Temperature: -35°C ~ 85°C
6. Mating Force: 3.57 Kg Max
7. Umating Force: 1.02 Kg Min

Material:

1. Housing: PBT , UL 94V-0
2. Contact: Phosphor Bronze
3. Shell: Phosphor Bronze / Spcc

Finish:

1. Contact: Plated Gold in Mating Area ;
Tin Plated on Solder Balls ;
Nickel under plated overall
2. Shell: Nickel under Plated surface layer

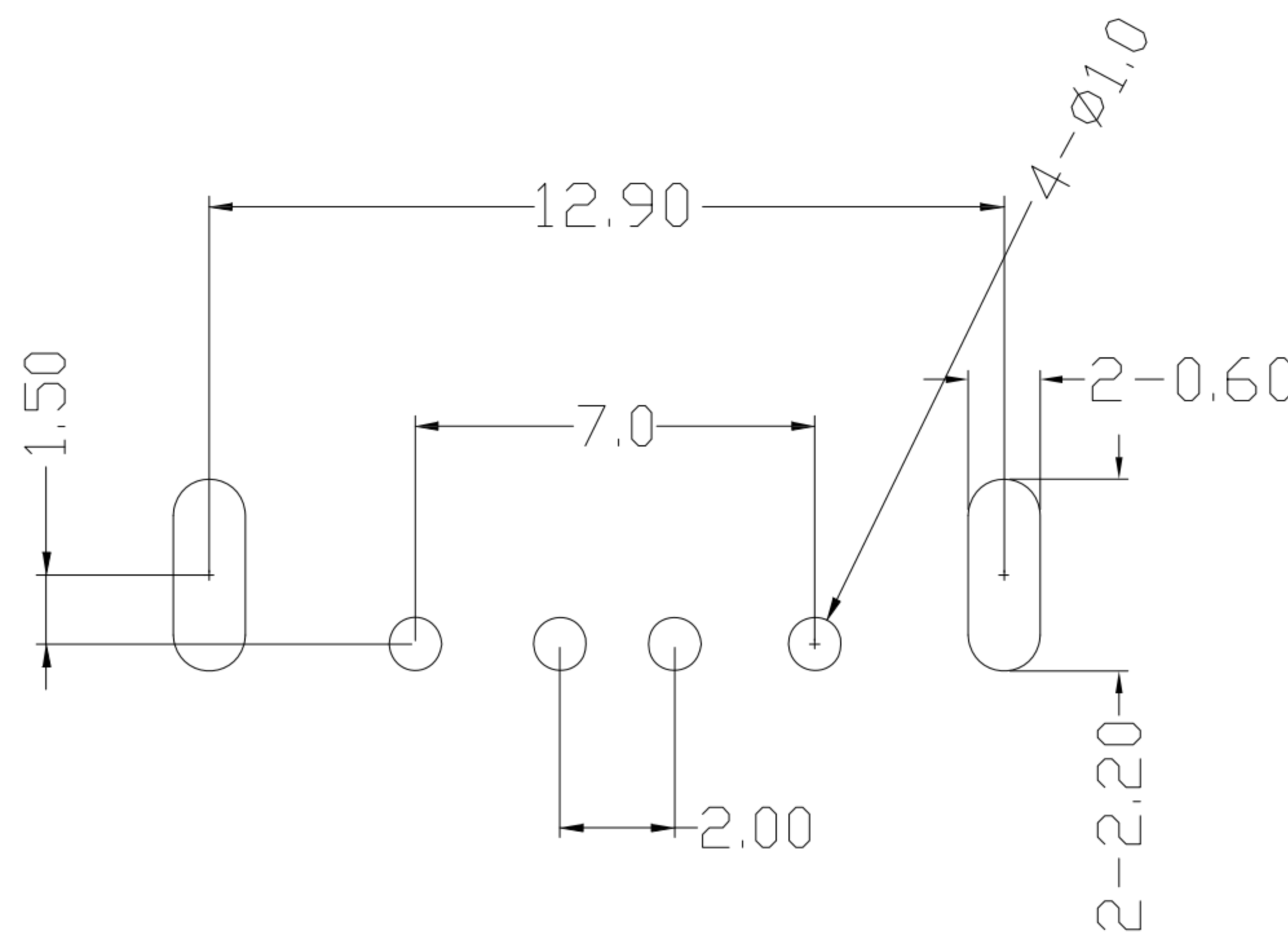
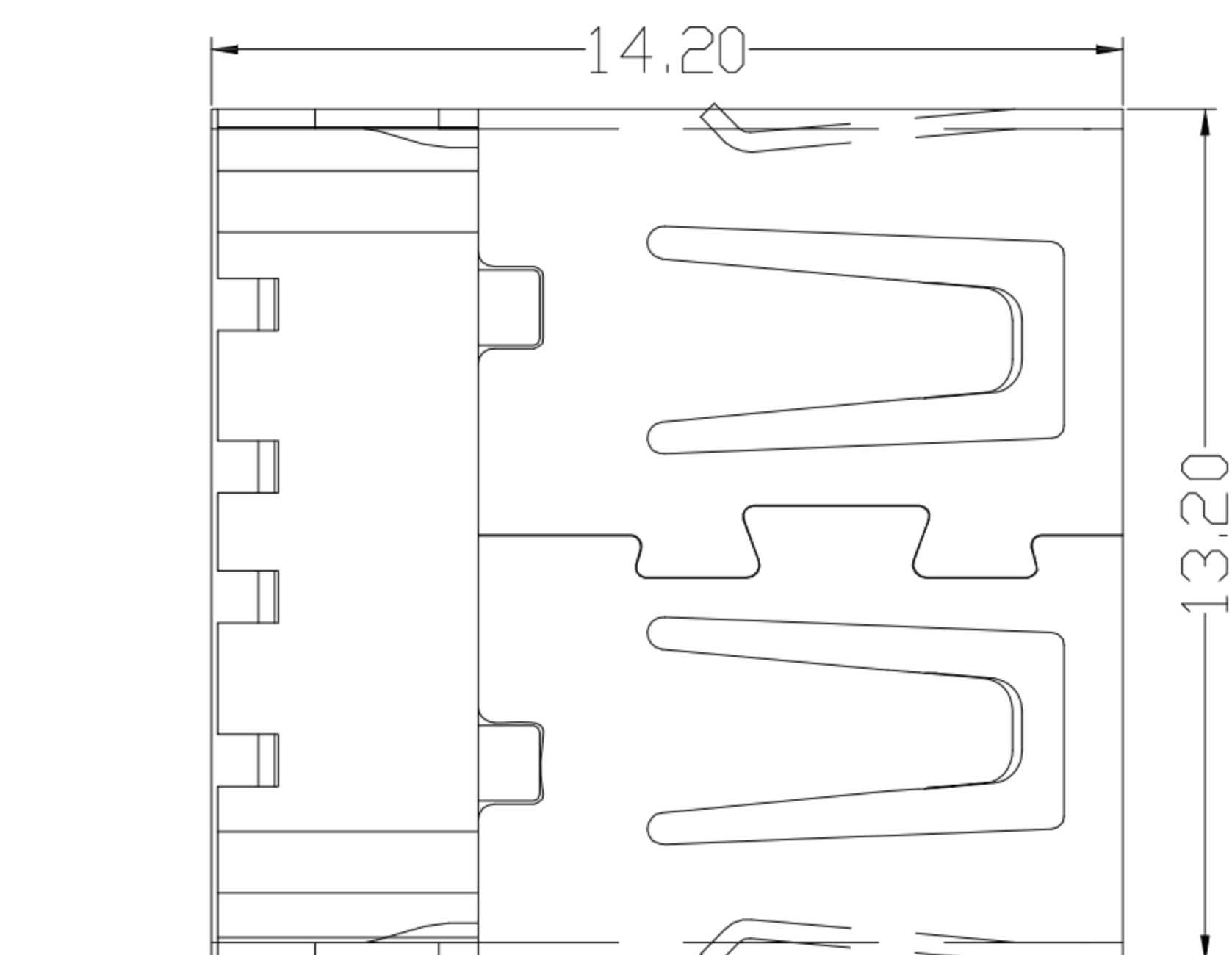

RECOMMEND P. C. B LAYOUT COMPONENT

6	更新尺寸	Jack	080715
5	更新pcb layout 外殼孔	Jack	072215
4	更新為A0版	Jack	031815
3	新增2.90和1.20兩個尺寸	Jack	121614
2	更新材質及SPEC	Jack	053014
1	更新尺寸	Jack	050514
ITEM NO.	DESCRIPTION	DRAWN	DATE

XB 东莞市溪榜电子有限公司
 Switch Connector DONG GUAN XI BANG ELECTRONICS CO., LTD

TOLERANCE UNLESS OTHERWISE STATED :
 Up to 5 ±0.2
 Above 5 ~ 15 ±0.3
 Above 15 ~ 30 ±0.4
 Above 30 ~ 50 ±0.5
 Angle ±0.3°

3RD. ANGEL'S

UNITS MM

DRAWN BY:	DATE	MAT'L	TITLE	CONNECTOR
Jack Lu	08/07/15			
CHECKED BY:	DATE	FINISH	MODLE	USB A/F 沉板H: 3.8mm 無捲邊
Jacky Chen	08/07/15			
APPROVED BY:	DATE	SCALE	DWG NO.	SUA-110E9x-x-S235
Tony Kao	08/07/15	1 : 1		
SHEET NO.	1 of 1	PART NO.	SUA-110E9x-x-S235	SIZE A4
				VER A2