

### SUA-110E21x-x-S316

SHELL :	COLOR :
Blank : Brass	Black: B
I : SPCC	White : W

### SPECIFICATIONS

#### Electrical:

- Contact Resistance: 30 mΩ Max
- Dielectric Withstanding Voltage: 500 V AC
- Insulation Resistance: 1,000 MΩ Min

#### Mechanical:

- Connector Mate and Unmate Force
  - Mate force: 3.57Kgf(Max)
  - Unmate force: 1.02Kgf (Min)

#### Material:

- Housing: PBT
- Contact: Phosphor Bronze
- Shell: Brass

#### Finish:

- Contact: Plated Gold in Mating Area ;  
Tin Plated on Solder Balls  
Nickel under plated overall
- Shell: Nickel under Plated surface layer

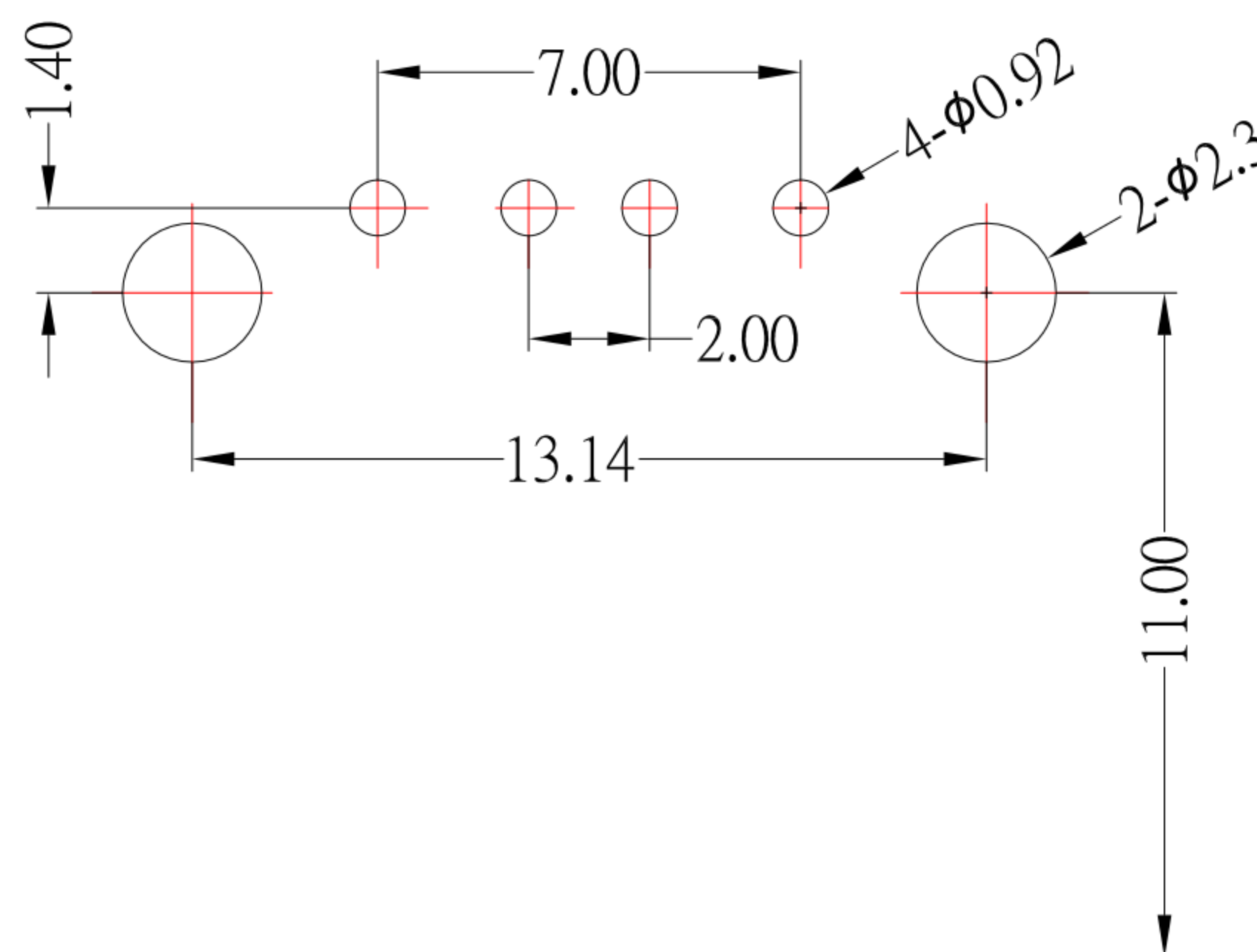
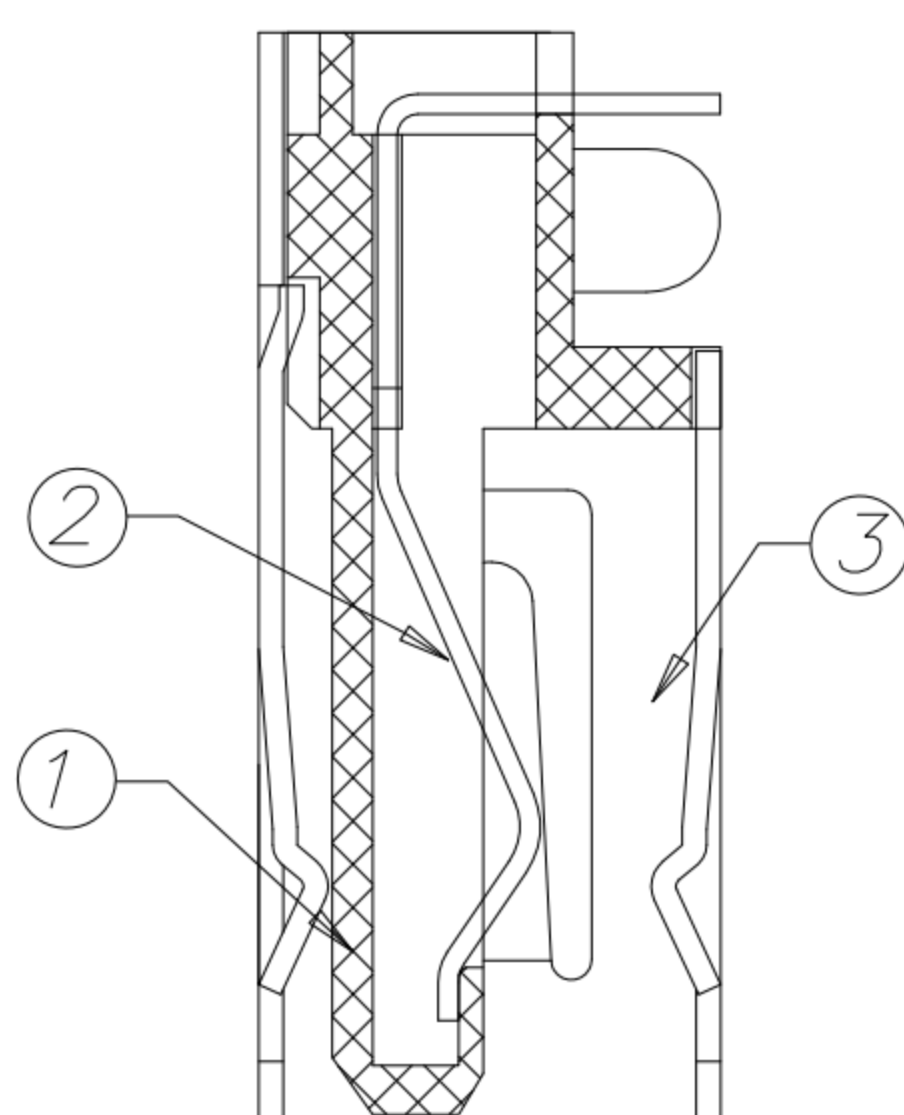
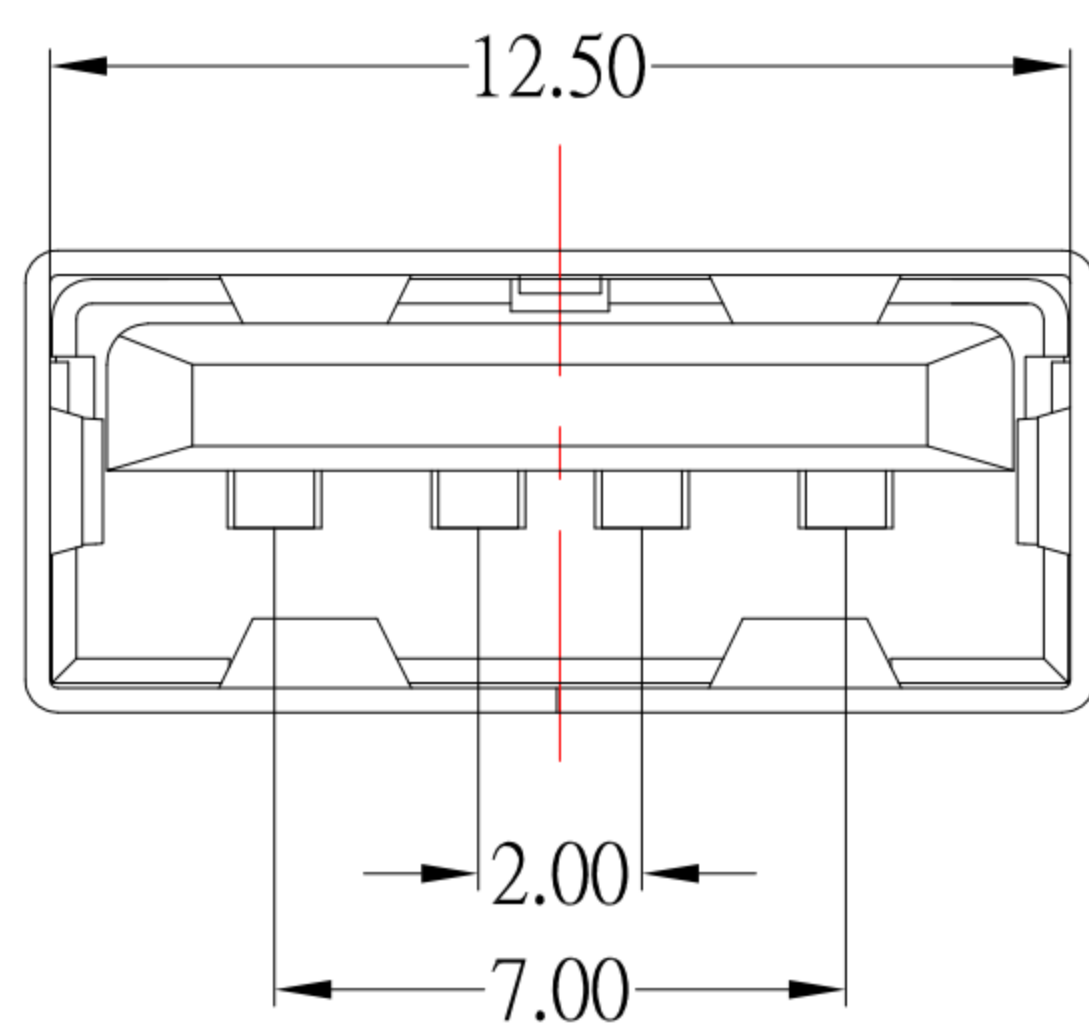

P.C.B LAYOUT MOUNTING PATTERN

**XGB** 东莞市溪榜电子有限公司  
Switch Connector DONG GUAN XI BANG ELECTRONICS CO., LTD

TOLERANCE UNLESS OTHERWISE STATED :  
Up to 5 ±0.2  
Above 5 ~ 15 ±0.3  
Above 15 ~ 30 ±0.4  
Above 30 ~ 50 ±0.5  
Angle ±0.3°

3RD. ANGEL'S

UNITS MM

DRAWN BY:	DATE	MAT'L	TITLE	CONNECTOR
Jack Lu	08/28/20		MODLE	USB AF 沉板 板上高 H3.8MM DIP 脚
CHECKED BY:	DATE	FINISH	DWG NO.	SUA-110E21x-x-S316
Jacky Chen	08/28/20		PART NO.	SUA-110E21x-x-S316
APPROVED BY:	DATE	SCALE	1 : 1	
Tony Kao	08/28/20	SHEET NO.	1 of 1	

1	更新圖面	Jack	082820
ITEM NO.	DESCRIPTION	DRAWN	DATE