

Specifications:

规格:
Voltage rating: 100V AC/DC
 额定电压: 100V AC/DC
Current rating: 1.5A AC/DC
 额定电流: 1.5A AC/DC
Withstanding voltage: 500V AC/minute
 耐受电压: 500V AC/分钟
Temperature range: -40°C~+105°C
 温度范围: -40°C~+105°C
Insulation resistance: ≥500MΩ
 绝缘电阻: ≥500MΩ
Contact resistance: ≤20mΩ
 接触电阻: ≤20mΩ

X1515 W V S- 2xXX - LP SW
 ① ② ③ ④ ⑤ ⑥ ⑦

- 1. Series No
- 2. Category: W-Wafer
- 3. Welding Board Angle: V-Straight 180°
- 4. Welding Way: S-SMT
- 5. Row No. Pin No: 2xXX-2x04~2x14P
- 6. Material: LP-LCP UL94V-0 (Natural)
- 7. Plating: SW- Matte Tin Plated

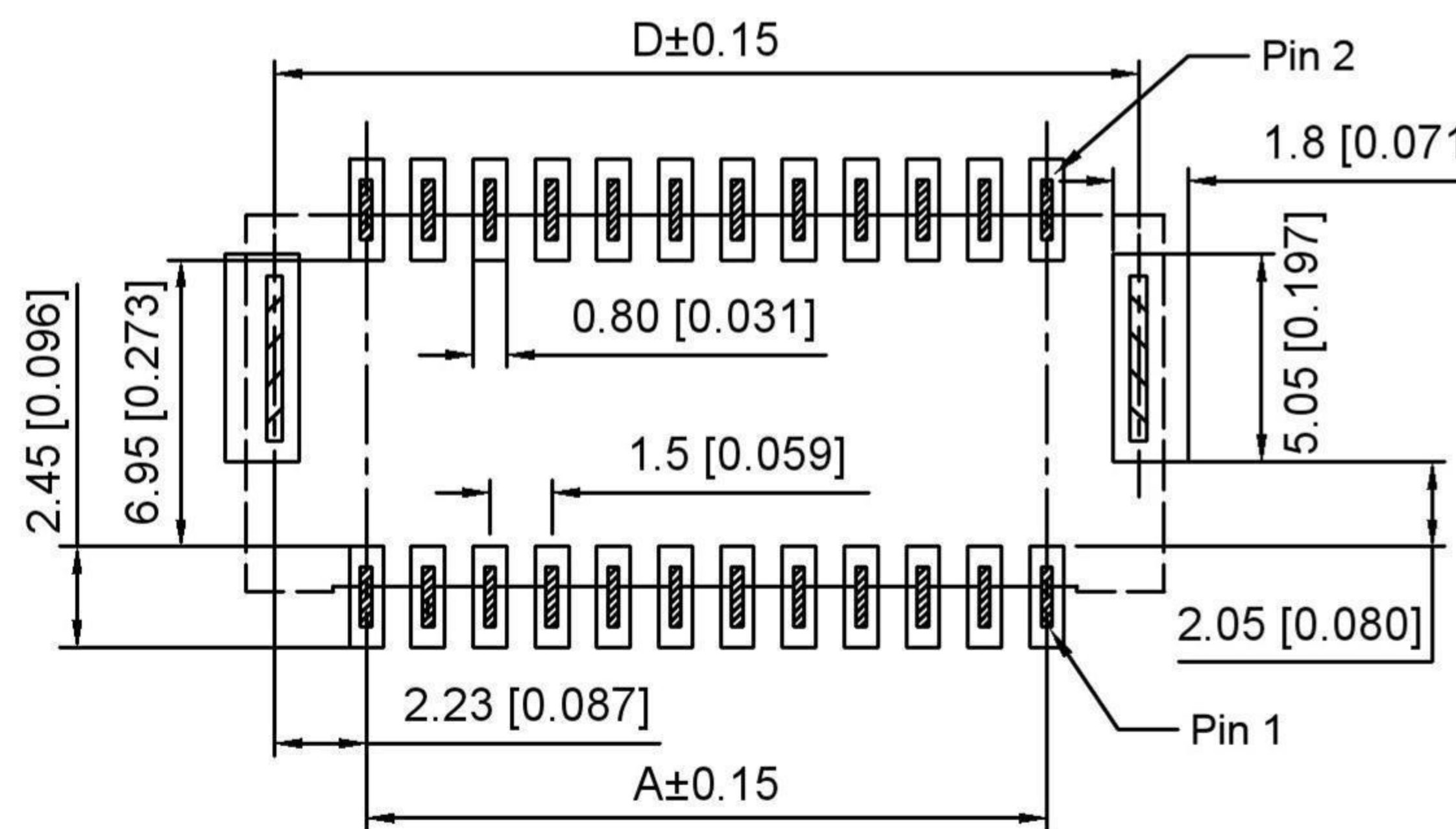

Recommended PCB Layout

Tolerance: ±0.05

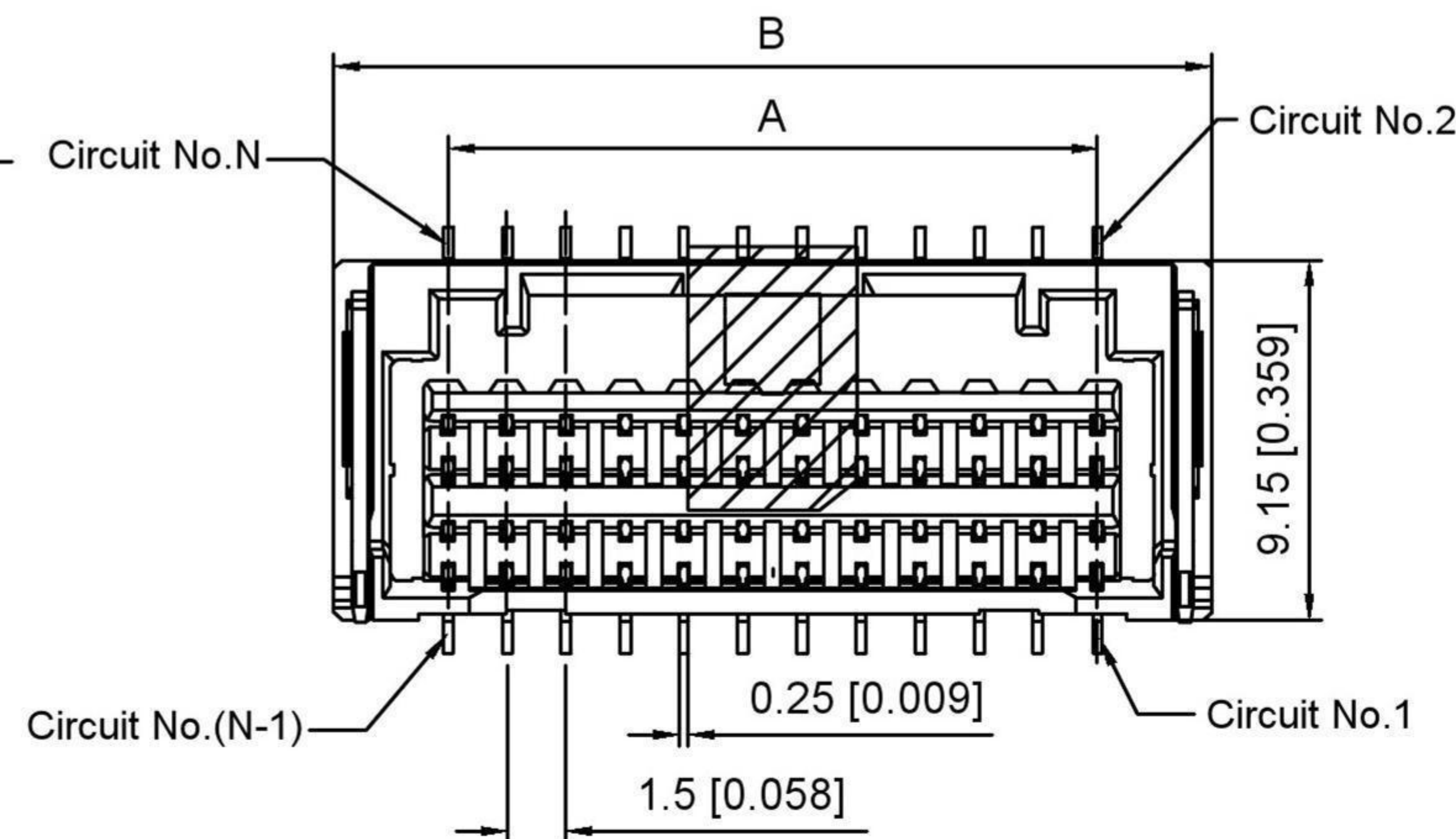

Poles	Dimensions(mm)			
	A	B	C	D
2x04	4.50	10.30	8.50	8.95
2x05	6.00	11.80	10.00	10.45
2x06	7.50	13.30	11.50	11.95
2x07	9.00	14.80	13.00	13.45
2x08	10.50	16.30	14.50	14.95
2x09	12.00	17.80	16.00	16.45
2x10	13.50	19.30	17.50	17.95
2x11	15.00	20.80	19.00	19.45
2x12	16.50	22.30	20.50	20.95
2x13	18.00	23.80	22.00	22.45
2x14	19.50	25.30	23.50	23.95

X1515WWS-2xXX-LPSW	LCP	Phosphor Bronze	X1515H-A	
PART NO	Material	Material(Pin)	Suitable	Housing

REVISIONS				ANGULAR	±5°
DATE	REVISED	APPROVED		L ≤ 4	±0.2
				4 < L ≤ 16	±0.3
				16 < L ≤ 63	±0.4
				L > 63	±0.5
				UNSPECIFIED TOLERANCES	
www.alpsr.com www.gdxjdz.com www.xbswitch.com					



DSND	SCALE: N/A	MODEL TYPE: BOARD TO BOARD CONNECTOR
DWN	VIEW:	
CHKD	UNIT: mm/in	PART NO.:
APPD	SIZE: A4	DWG NO.:
DONG GUAN XI BANG ELECTRONIC CO., LTD		WEIGHT
		SHEET
		1/1
		REVISION
		A0

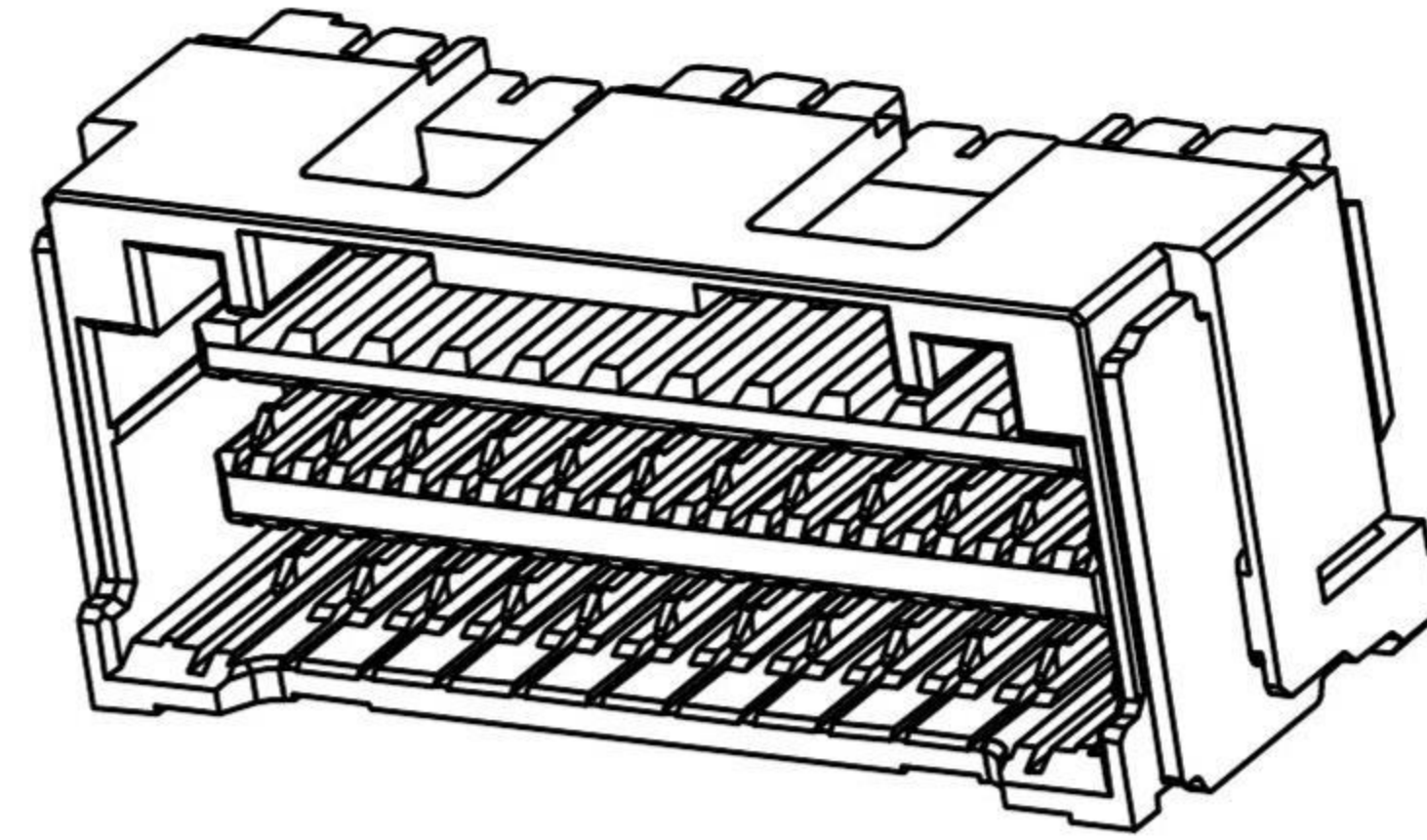
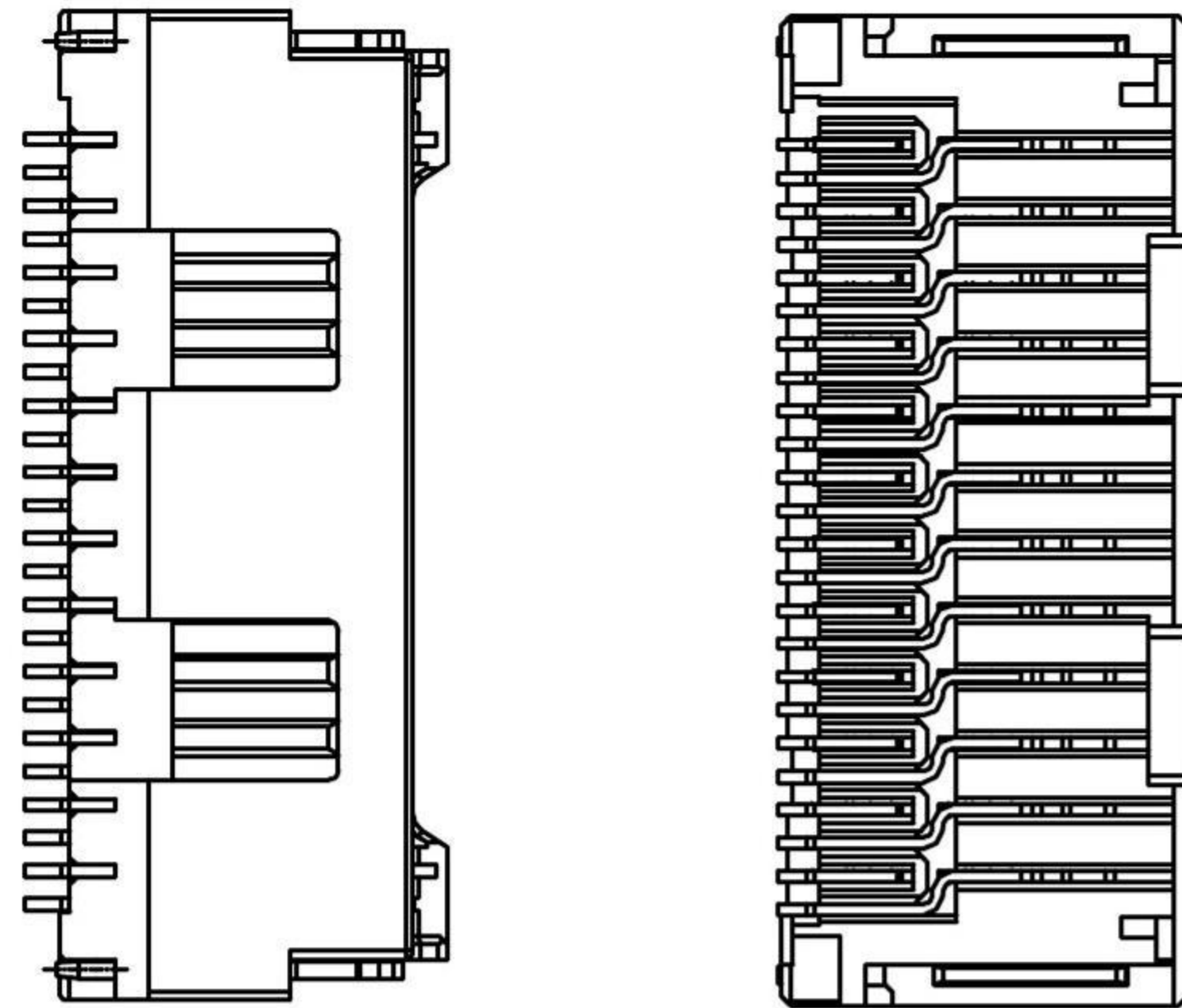

Specifications:

规格:

Voltage rating:100V AC/DC

额定电压: 100V AC/DC

Current rating:1.5A AC/DC

额定电流: 1.5A AC/DC

Withstanding voltage:500V AC/minute

耐受电压: 500V AC/分钟

Temperature range:-40°C-+105°C

温度范围: -40°C-+105°C

Insulation resistance:≥500MΩ

绝缘电阻: ≥500MΩ

Contact resistance:≤20mΩ

接触电阻: ≤20mΩ

2x04Pin / 2x05Pin With Mylar

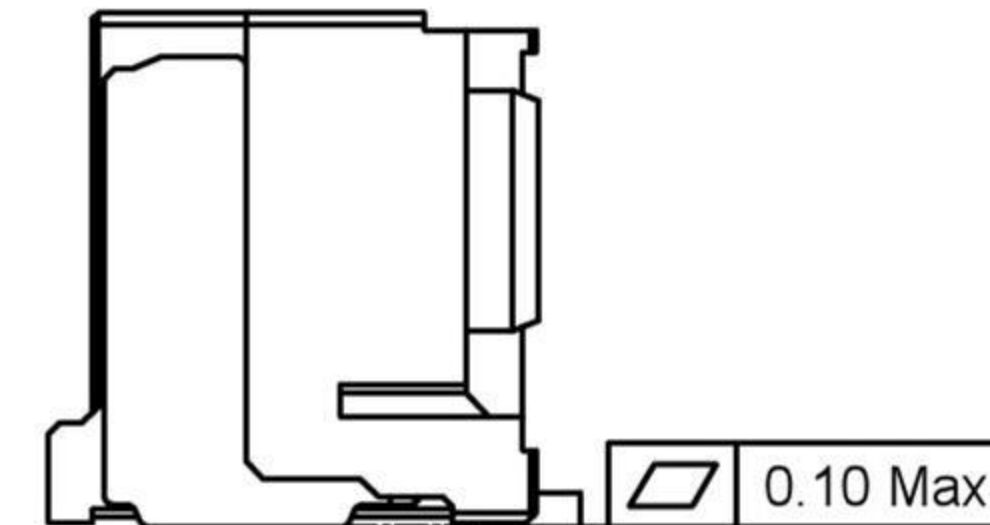
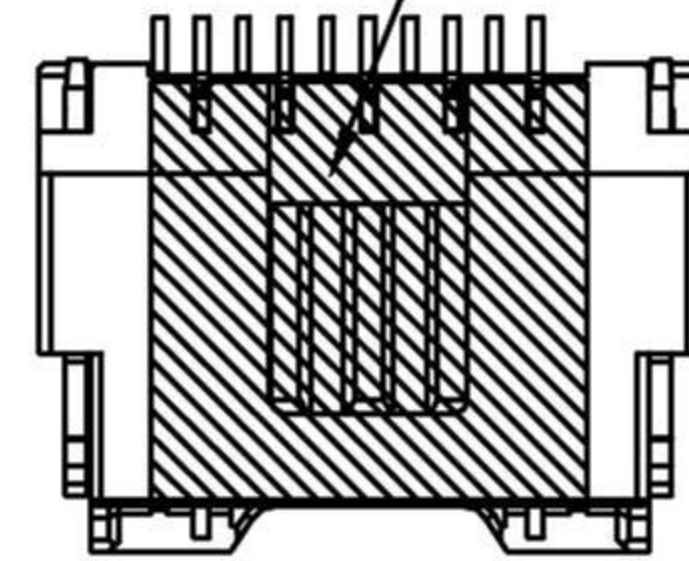

2x04Pin
2x05Pin

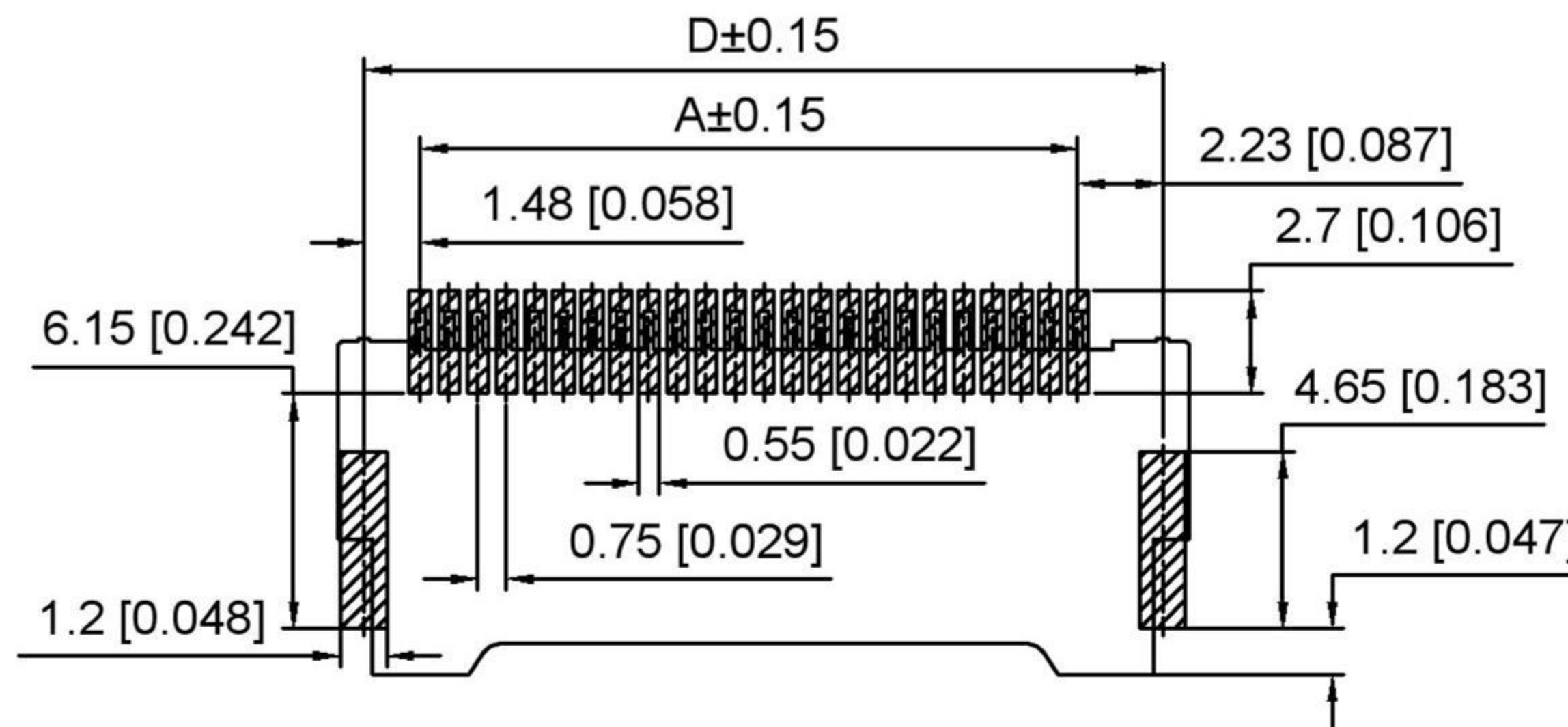
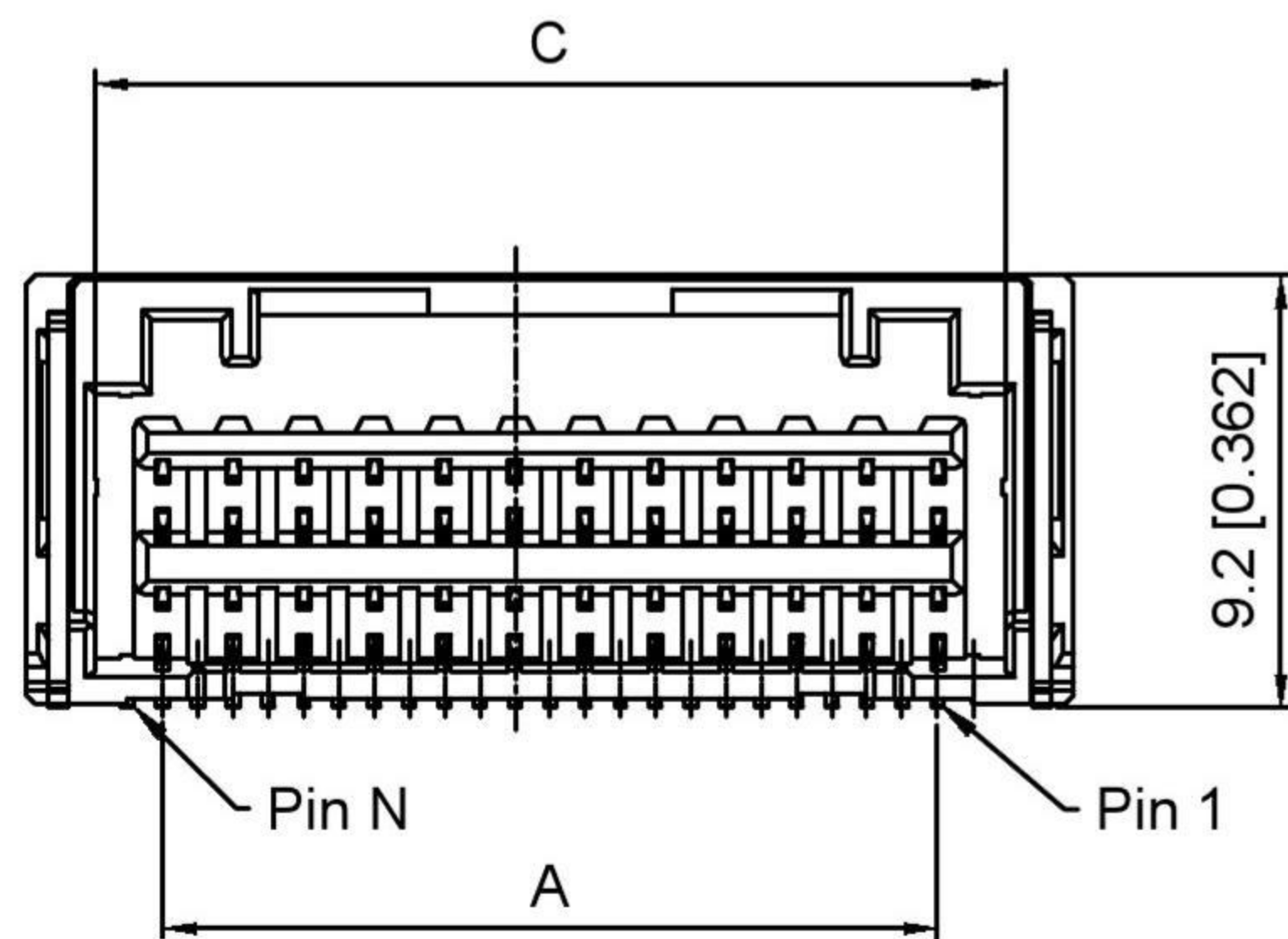
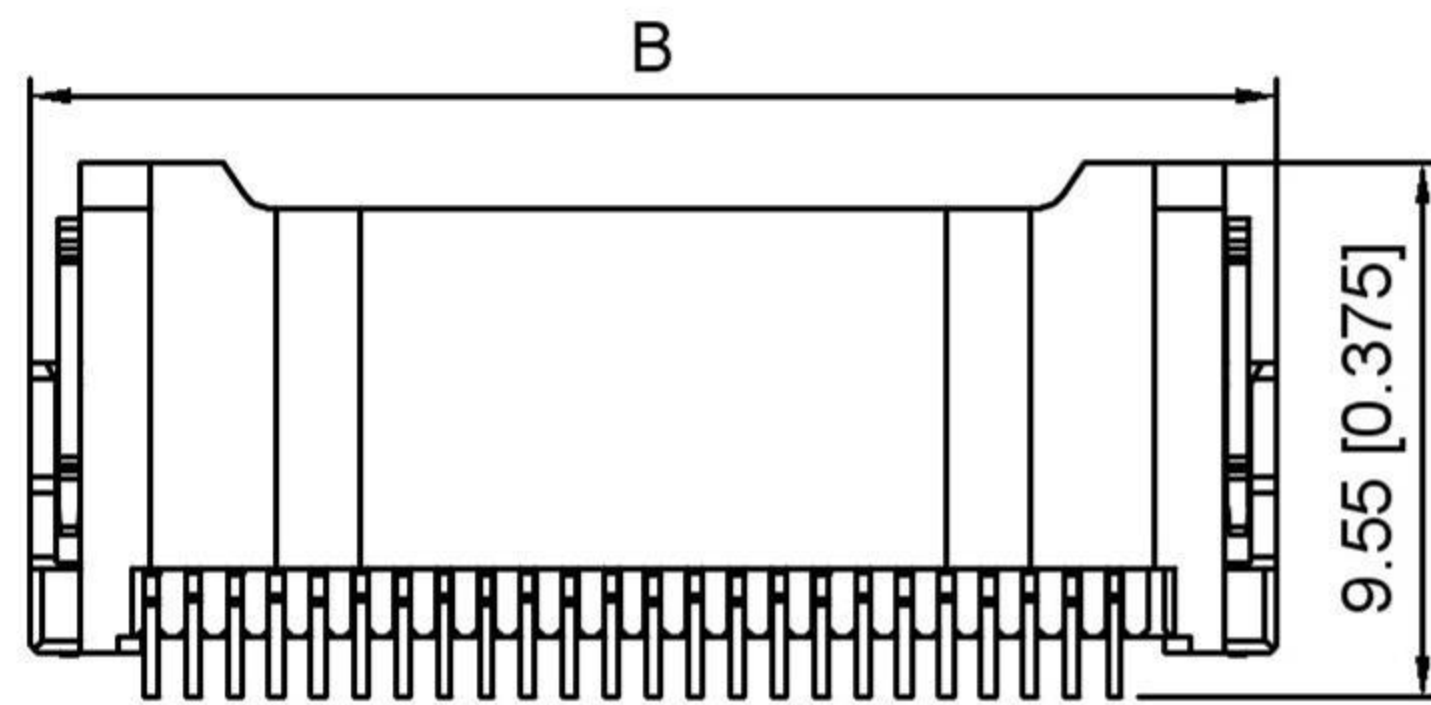

Recommended PCB Layout
Tolerance:±0.05

X1515 W R S- 2xXX - LP SW
① ② ③ ④ ⑤ ⑥ ⑦

1.Series No

2.Category:W-Wafer

3.Welding Board Angle:R-Stright 90°

4.Welding Way:S-SMT

5.Row No.Pin No:2xXX-2x04~2x14P

6.Material:LP-LCP 94V-0 (Natural)

7.Plating:SW- Matte Tin Plated

Poles	Dimensions(mm)			
	A	B	C	D
2x04	4.50	10.30	7.40	8.95
2x05	6.00	11.80	8.90	10.45
2x06	7.50	13.30	10.40	11.95
2x07	9.00	14.80	11.90	13.45
2x08	10.50	16.30	13.40	14.95
2x09	12.00	17.80	14.90	16.45
2x10	13.50	19.30	16.40	17.95
2x11	15.00	20.80	17.90	19.45
2x12	16.50	22.30	19.40	20.95
2x13	18.00	23.80	20.90	22.45
2x14	19.50	25.30	22.40	23.95

X1515WRS-2xXX-LPSW	LCP	Phosphor Bronze	X1515H-A	
PART NO	Material	Material(Pin)	Suitable	Housing

REVISIONS				ANGULAR	±5°
				L ≤ 4	±0.2
				4 < L ≤ 16	±0.3
				16 < L ≤ 63	±0.4
				L > 63	±0.5
	DATE	REVISED	APPROVED	UNSPECIFIED TOLERANCES	
www.alpsr.com www.gdxjdz.com www.xbswitch.com					



DSND	SCALE: N/A	MODEL TYPE:		
DWN	VIEW:	BOARD TO BOARD CONNECTOR		
CHKD	UNIT: mm/in	PART NO.:		
APPD	SIZE: A4	DWG NO.:		
		WEIGHT	SHEET	REVISION
DONG GUAN XI BANG ELECTRONIC CO., LTD			1/1	A0

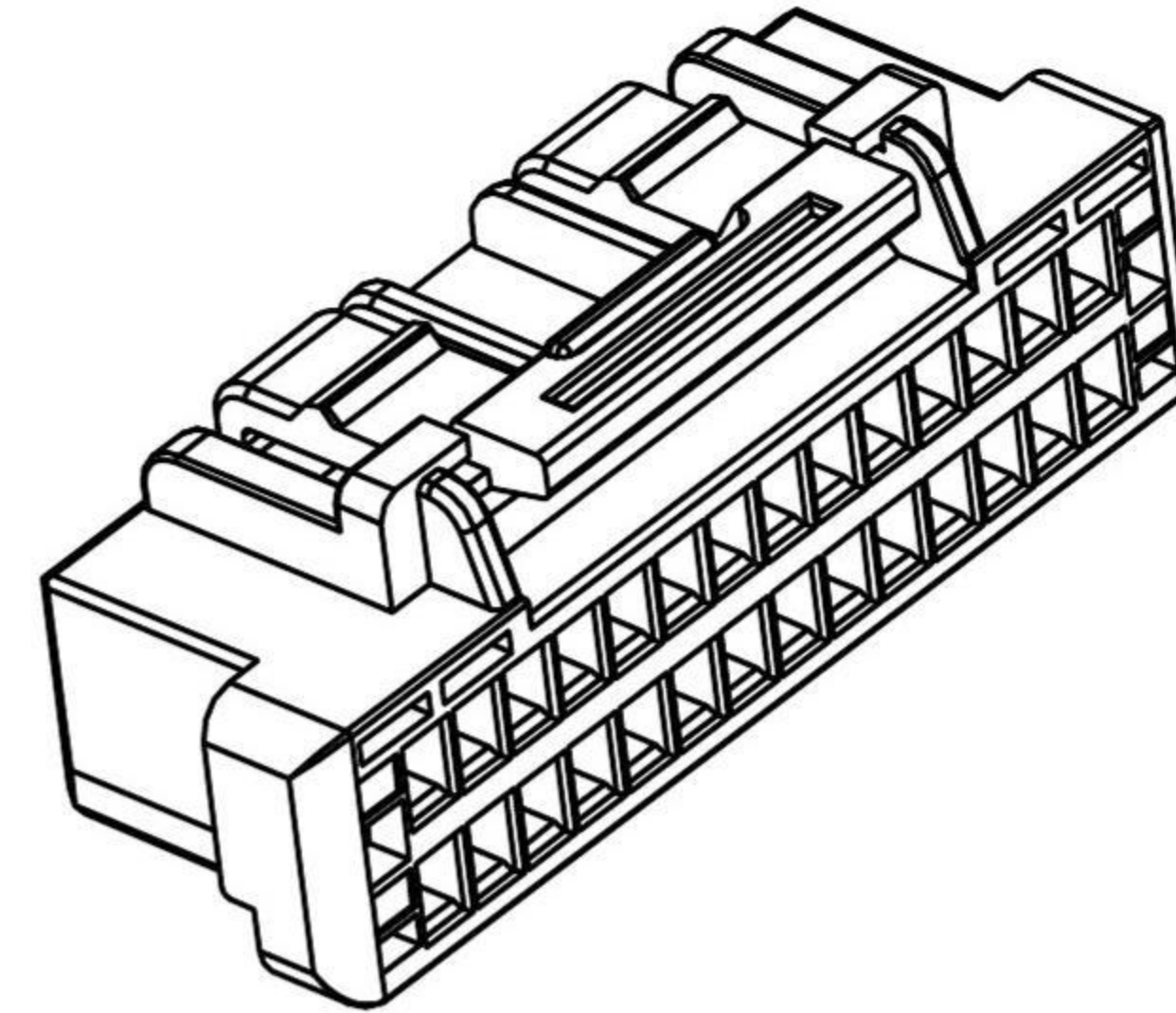
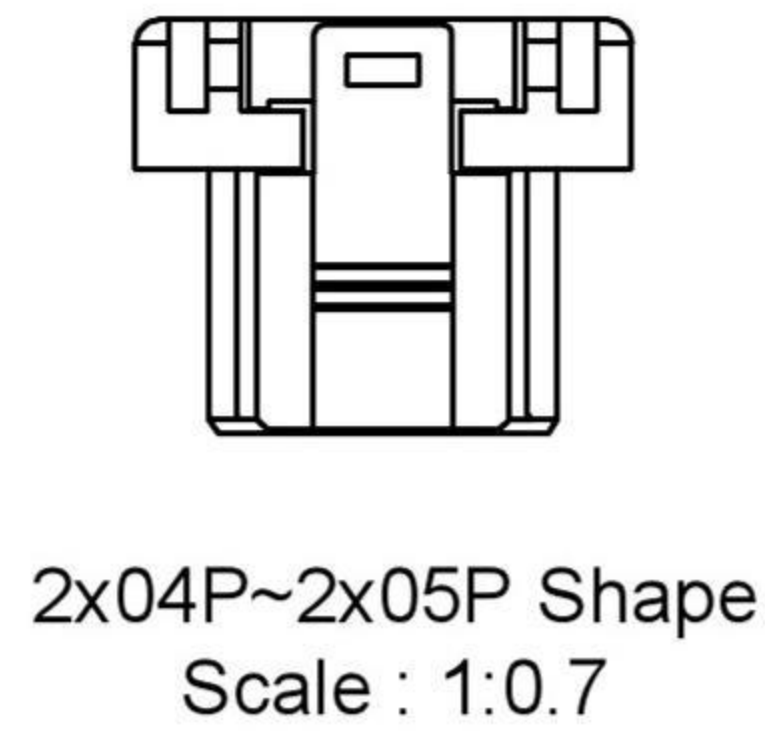
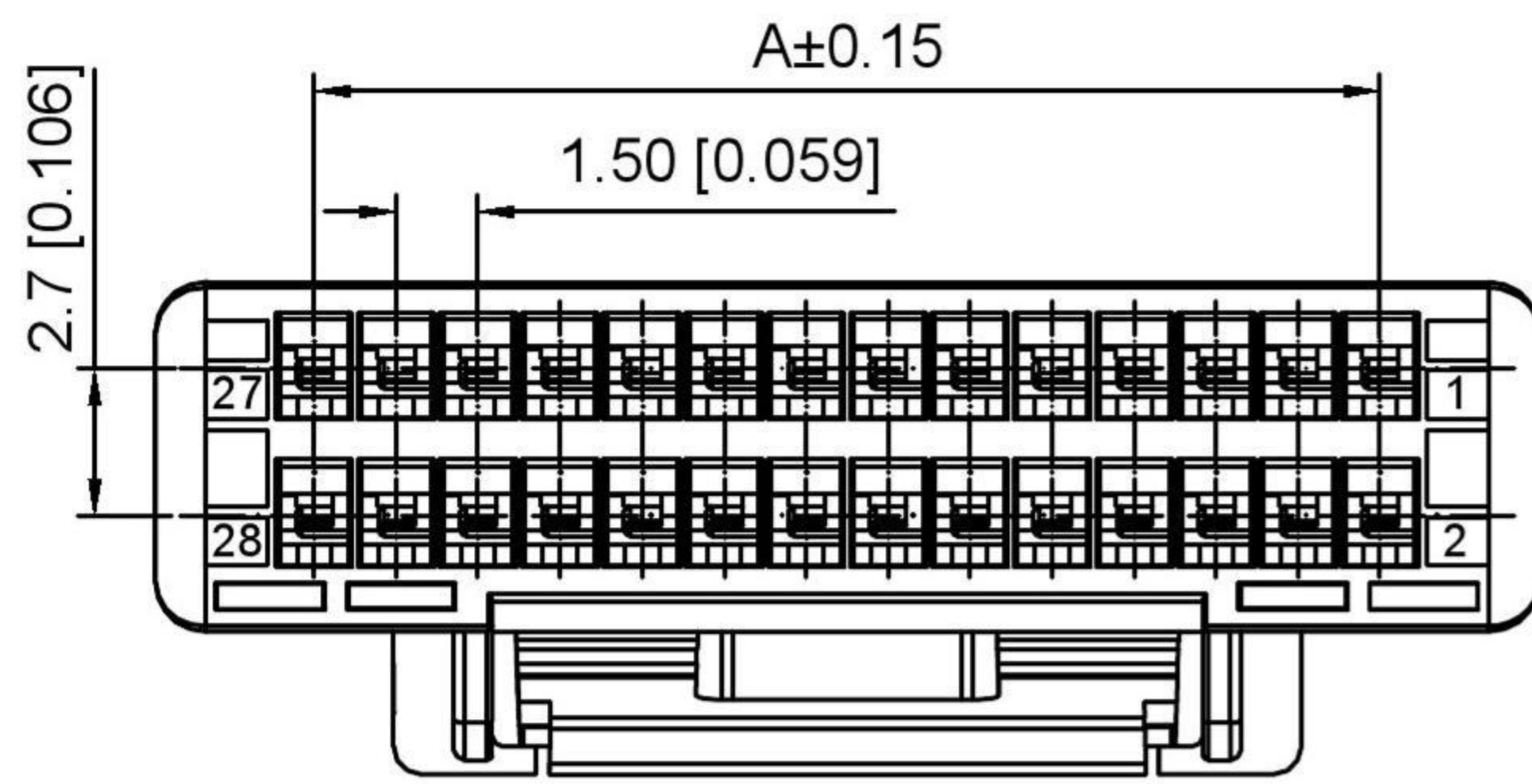

Specifications:
 规格:
 Voltage rating:100V AC/DC
 额定电压: 100V AC/DC
 Current rating:1.5A AC/DC
 额定电流: 1.5A AC/DC
 Withstanding voltage:500V AC/minute
 耐受电压: 500V AC/分钟
 Temperature range:-40°C~+105°C
 温度范围: -40°C~+105°C
 Insulation resistance:≥500MΩ
 绝缘电阻: ≥500MΩ
 Contact resistance:≤20mΩ
 接触电阻: ≤20mΩ

X1515 H - 2xXX - PT
 ① ② ③ ④

1.Series No
 2.Category:H-HSG
 3.Row No.Pin No:2xXX-2x04~2x17P
 4.Material:PT-PBT UL94V-0 (Natural)

Poles	Dimensions(mm)		
	A	B	C
2x04	4.50	10.30	7.25
2x05	6.00	11.80	8.75
2x06	7.50	13.30	10.25
2x07	9.00	14.80	11.75
2x08	10.50	16.30	13.25
2x09	12.00	17.80	14.75
2x10	13.50	19.30	16.25
2x11	15.00	20.80	17.75
2x12	16.50	22.30	19.25
2x13	18.00	23.80	20.75
2x14	19.50	25.30	22.25
2x15	21.00	26.80	23.75
2x16	22.50	28.30	25.25
2x17	21.00	29.80	26.75

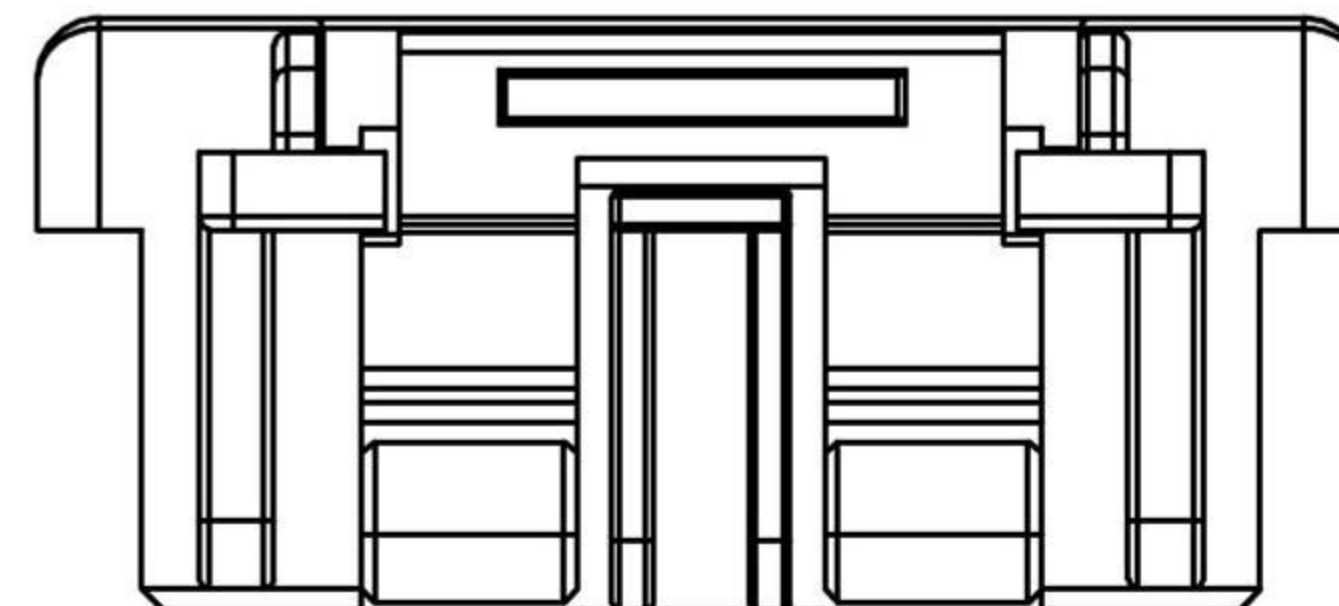
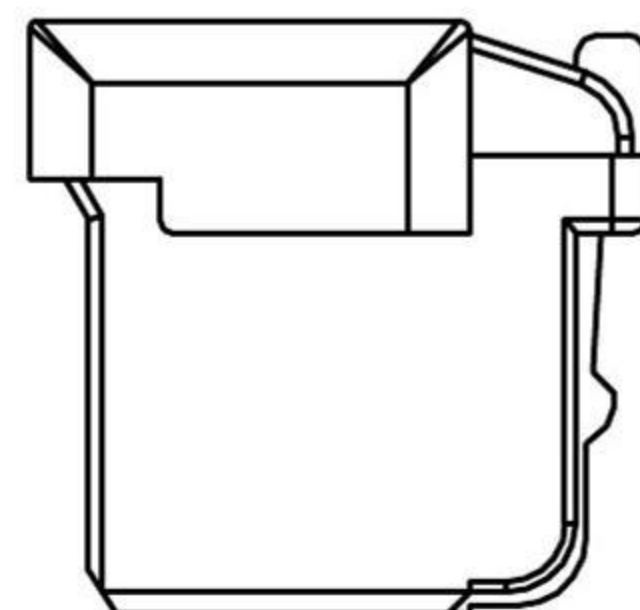
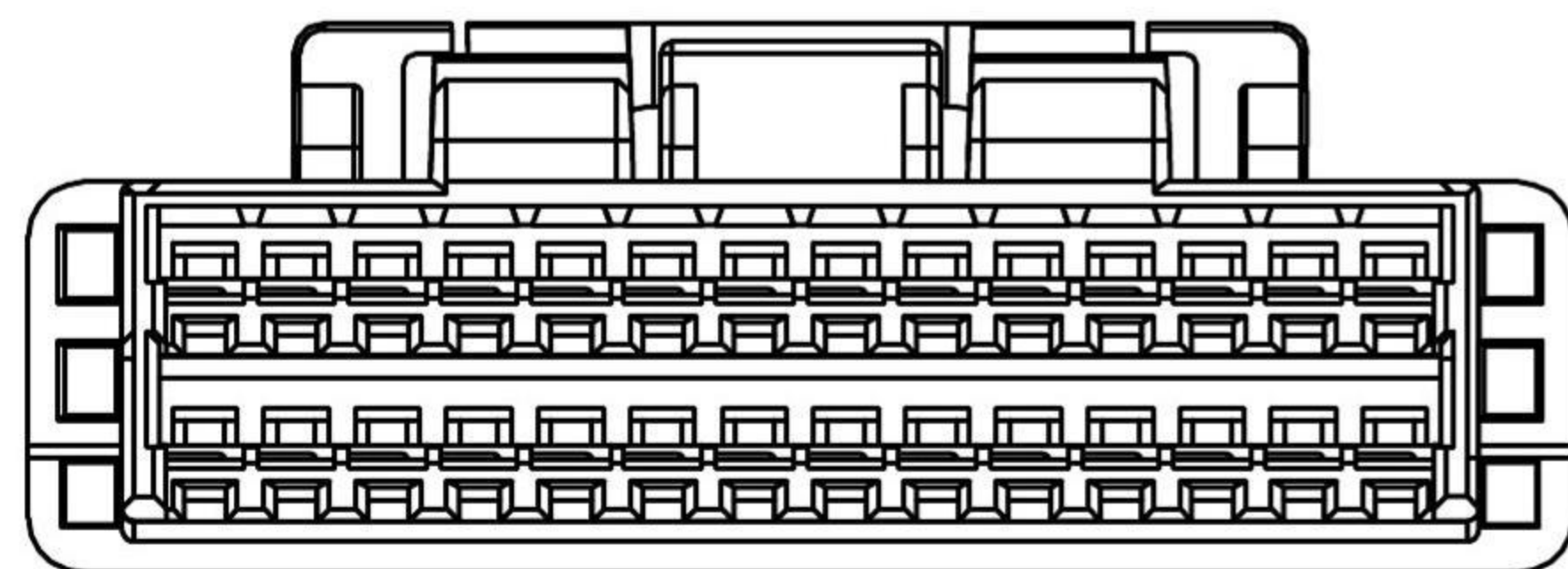
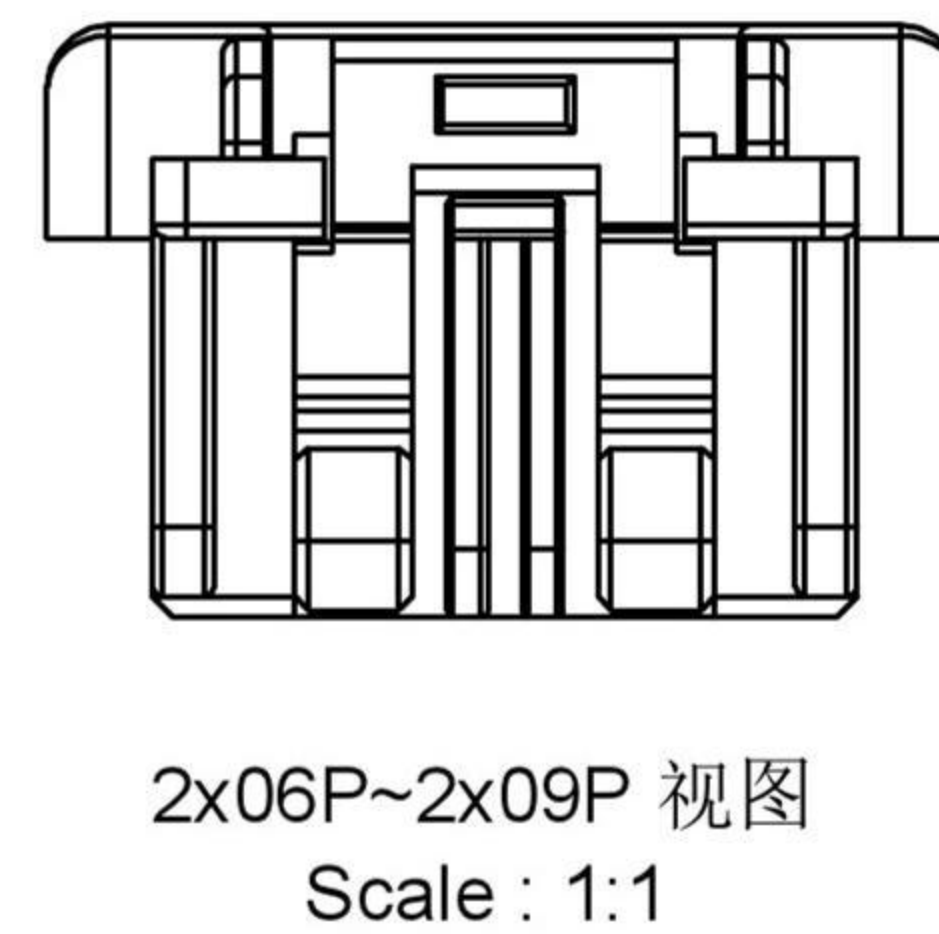
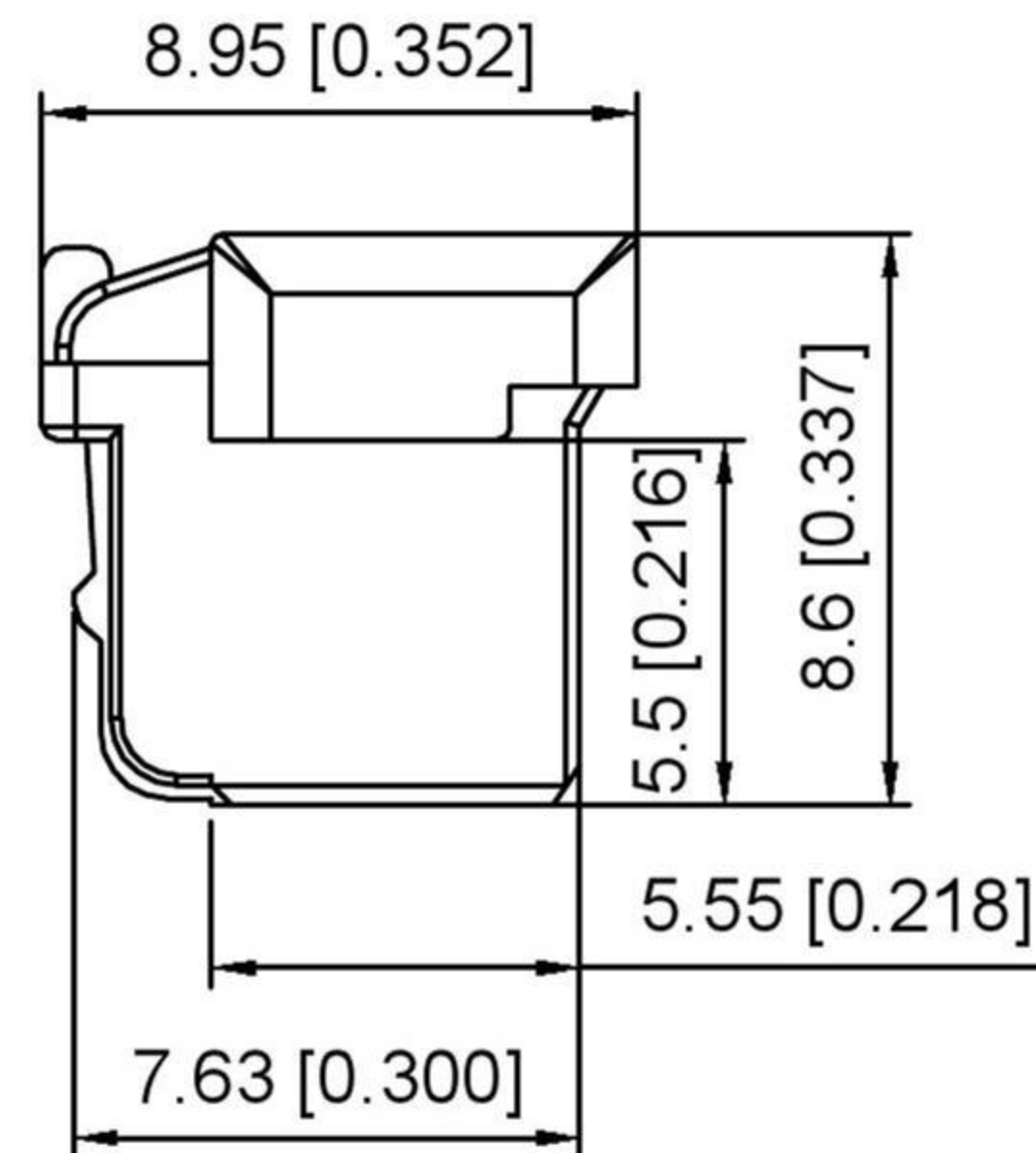
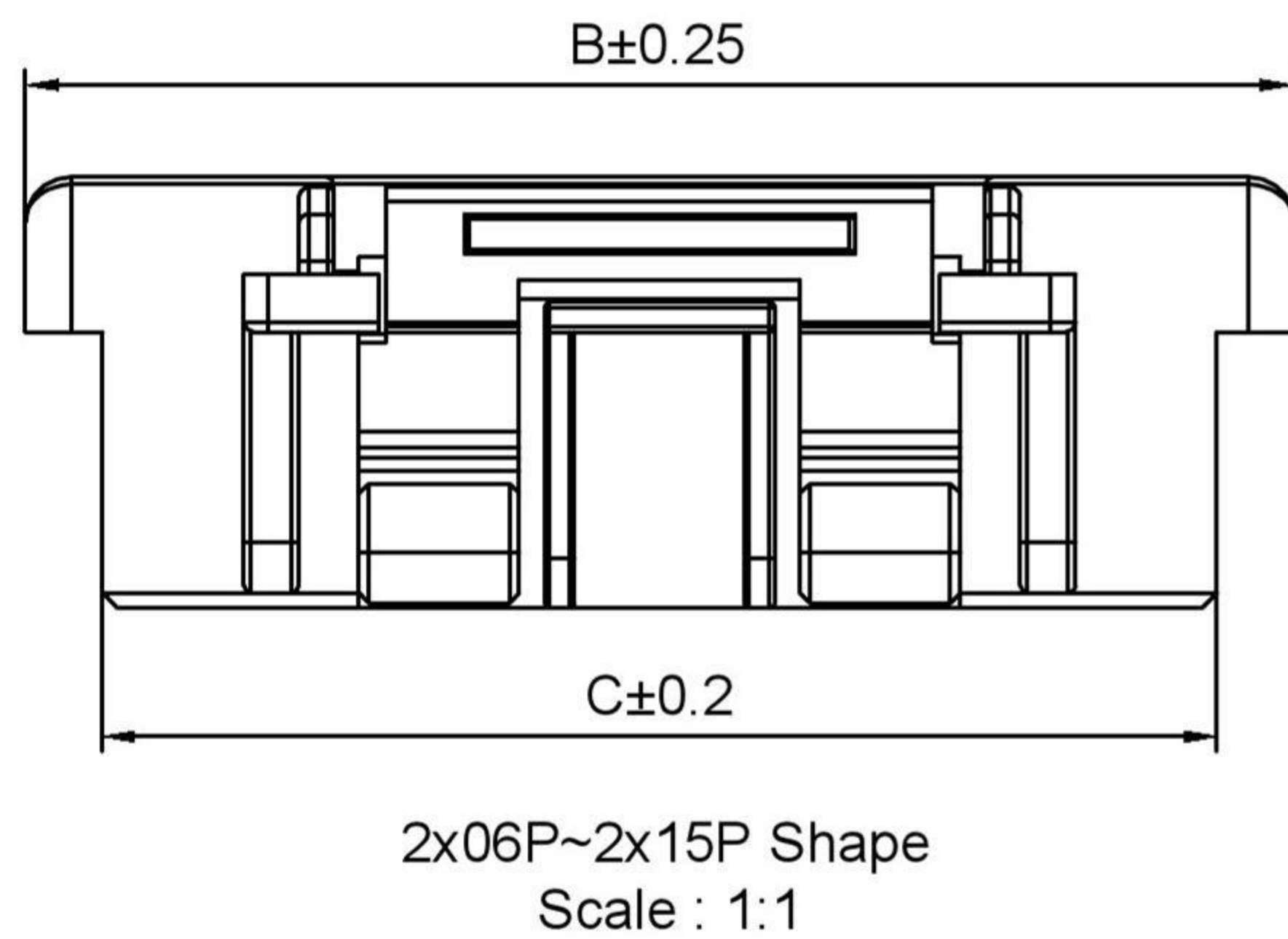

2x10P~2x17P 视图
 Scale: 1:1

X1515H-2xXX-PT	PBT	X1515W-A		X1515T-A	
PART NO	Material	Suitable	Wafer	Suitable	Terminal

DSND		SCALE: N/A	MODEL TYPE: BOARD TO BOARD CONNECTOR
DWN		VIEW:	PART NO.:
CHKD		UNIT: mm/in	DWG NO.:
APPD		SIZE: A4	
REVISIONS			WEIGHT
www.alpsr.com www.gdxjdz.com www.xbswitch.com			SHEET
			1/1
			REVISION
			A0



DONG GUAN XI BANG ELECTRONIC CO., LTD

ANGLAR	±5°
L ≤ 4	±0.2
4 < L ≤ 16	±0.3
16 < L ≤ 63	±0.4
L > 63	±0.5

UNSPECIFIED TOLERANCES

DATE REVISED APPROVED