

3D VIEW

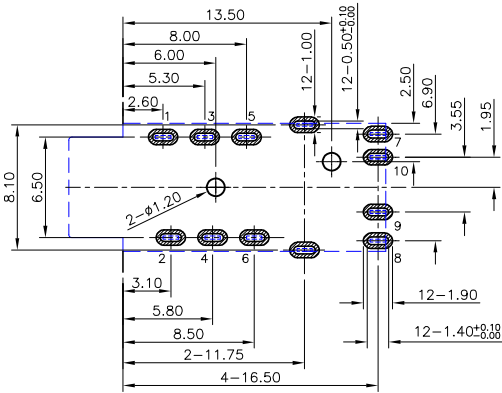

RECOMMENDED PCB LAYOUT  
TOP VIEW TOL:±0.05

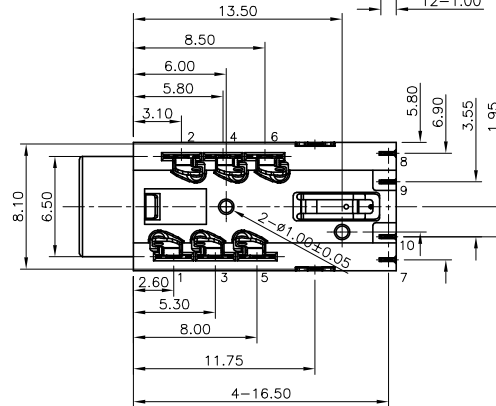

- NOTES:
- MATERIAL: SEE "TABLE 1";
  - FINISH: SEE "TABLE 1";
  - ELECTRICAL:
    - VOLTAGE RATING: 12 VAC RMS;
    - CURRENT RATING: 0.5 AMP;
    - CONTACT RESISTANCE: 50mΩ Max.(Initial), 100mΩ Max.(After Life test);
    - INSULATION RESISTANCE: 1000 MΩ Min., 500VDC.(Initial), 100 MΩ Min., 500VDC.(After Humidity test);
    - WITHSTAND VOLTAGE: 500 VAC RMS 50(60)Hz, 1 minute;
  - MECHANICAL:
    - MATING FORCE: 3.0Kgf MAX.;
    - UNMATING FORCE: 0.3Kgf MIN.;
    - OPERATING LIFE: 5000 CYCLES MIN.;
  - ENVIRONMENTAL:
    - OPERATION: -30°C~+80°C.

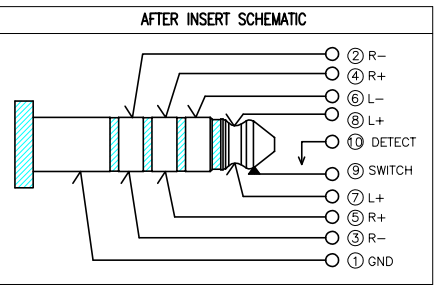
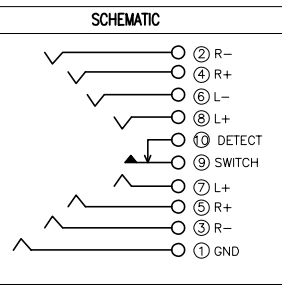
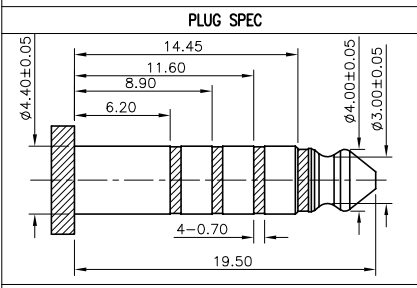

TABLE 1:

NO.	PART NAME	QTY	MATERIAL	DESCRIPTION	REMARK
14	HOUSING	1	HIGH TEMP. PLASTIC	BLACK COLOR,UL94V-HB	
13	INSULATOR	1	HIGH TEMP. PLASTIC	BLACK COLOR,UL94V-HB	
12	SOCKET	1	BRASS	GOLD FLASH	T=0.25mm
11	CONTACT	1	PHOSPHOR BRONZE	Ni PLATED	T=0.20mm
10	CONTACT	1	STAINLESS STEEL	CONTACT:5u" Au/SOLDER:1u"Au	T=0.20mm
9	CONTACT	1	STAINLESS STEEL	CONTACT:5u" Au/SOLDER:1u"Au	T=0.20mm
8	CONTACT	1	STAINLESS STEEL	CONTACT:5u" Au/SOLDER:1u"Au	T=0.20mm
7	CONTACT	1	STAINLESS STEEL	CONTACT:5u" Au/SOLDER:1u"Au	T=0.20mm
1~6	CONTACT	6	STAINLESS STEEL	CONTACT:5u" Au/SOLDER:1u"Au	T=0.20mm

UNLESS OTHERWISE SPECIFIED TOLERANCES

**XB** 东莞市溪榜电子有限公司  
DONG GUAN XI BANG ELECTRONICS CO., LTD.

DECIMALS:	ANGLES:	DESIGN:	Tony
DIM TOL	DIM TOL	CHECK:	2021.5.7
X. ±0.50	X. ±2°	APPROVED:	Andy
X.X ±0.30	X.X ±1°	UNIT:	2021.5.8
X.XX ±0.20	X.XX	3RD ANGLE PROJECTION	
X.XXX ±0.10	X.XXX		

PART NAME:	Φ3.5 PHONE JACK
PART NO.	XB-PJ04410-0760-00000H
SHEET:	1/1
REV.:	A1
DRAWING NO	

REV.	ECN NO.	DESCRIPTION	DESIGN	DATE
------	---------	-------------	--------	------

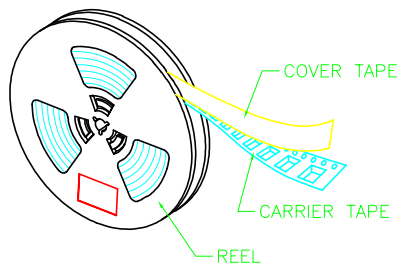
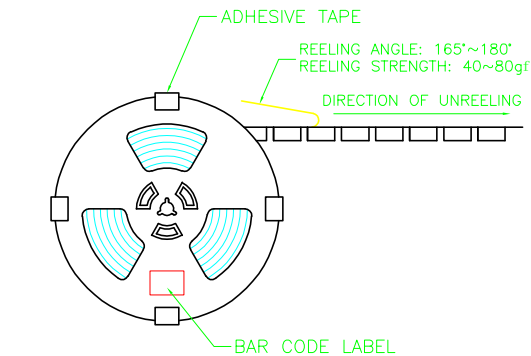
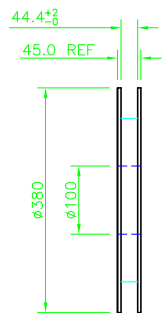
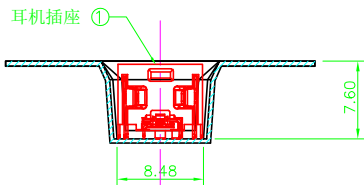
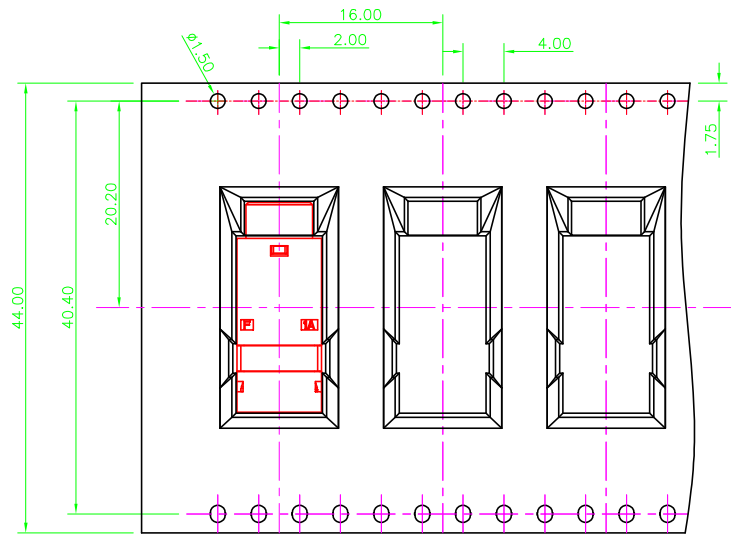

TOTAL 10 LAYERS

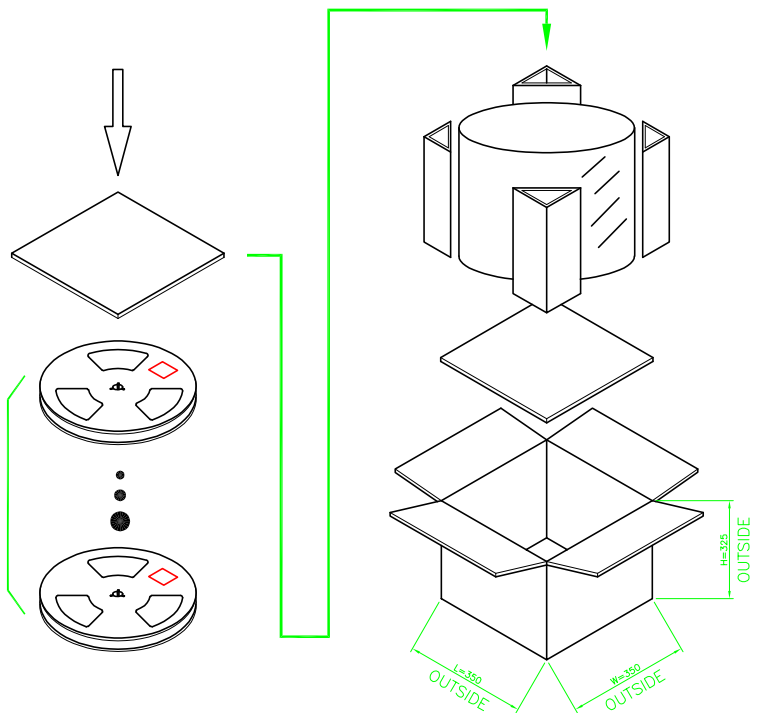

- NOTES:  
 1. PRIMARY PACKING: 700 PCS/REEL;  
 2. SECONDARY PACKING: 6 REELS/CARTON (4,200 PCS/CARTON);  
 3. PRODUCT MEET THE REQUEST OF THE RoHS.

USER DIRECTION OF UNREELING

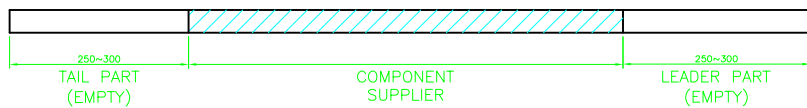

UNLESS OTHERWISE SPECIFIED TOLERANCES				东莞市溪榜电子有限公司 DONG GUAN XI BANG ELECTRONICS CO., LTD.	
DECIMALS:		ANGLES:		DESIGN:	Tony
DIM	TOL	DIM	TOL		2021.5.7
X.	±0.50	X.	±2°	CHECK:	
X.X	±0.30	X.X	±1°		
X.XX	±0.20	X.XX	—	APPROVED	Andy
X.XXX	±0.10	X.XXX	—		2021.5.8
3RD ANGLE PROJECTION				UNIT:	mm
				PART NAME:	Φ3.5 PHONE JACK
					-包装图
				PART NO.	XB-PJ04410-0760-00000H
				SHEET: 1/1	REV.: A1
				DRAWING NO	

REV.	ECN NO.	DESCRIPTION	DESIGN	DATE
------	---------	-------------	--------	------