

S:Scrolls

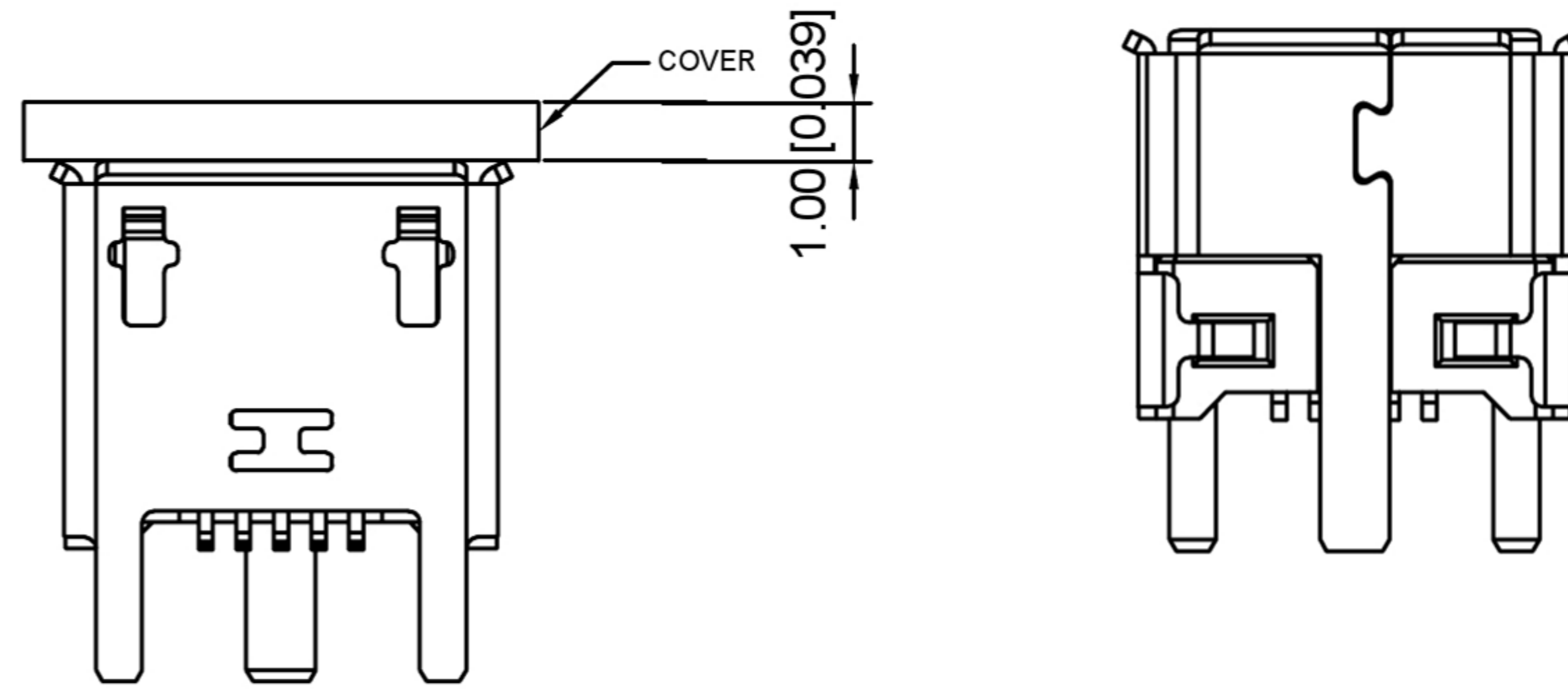

XB-U255-051N-4BH74

1:AU 1U"
5:AU 15U"
6:AU 30U"

S:SUS
S:Scrolls
F:Flat

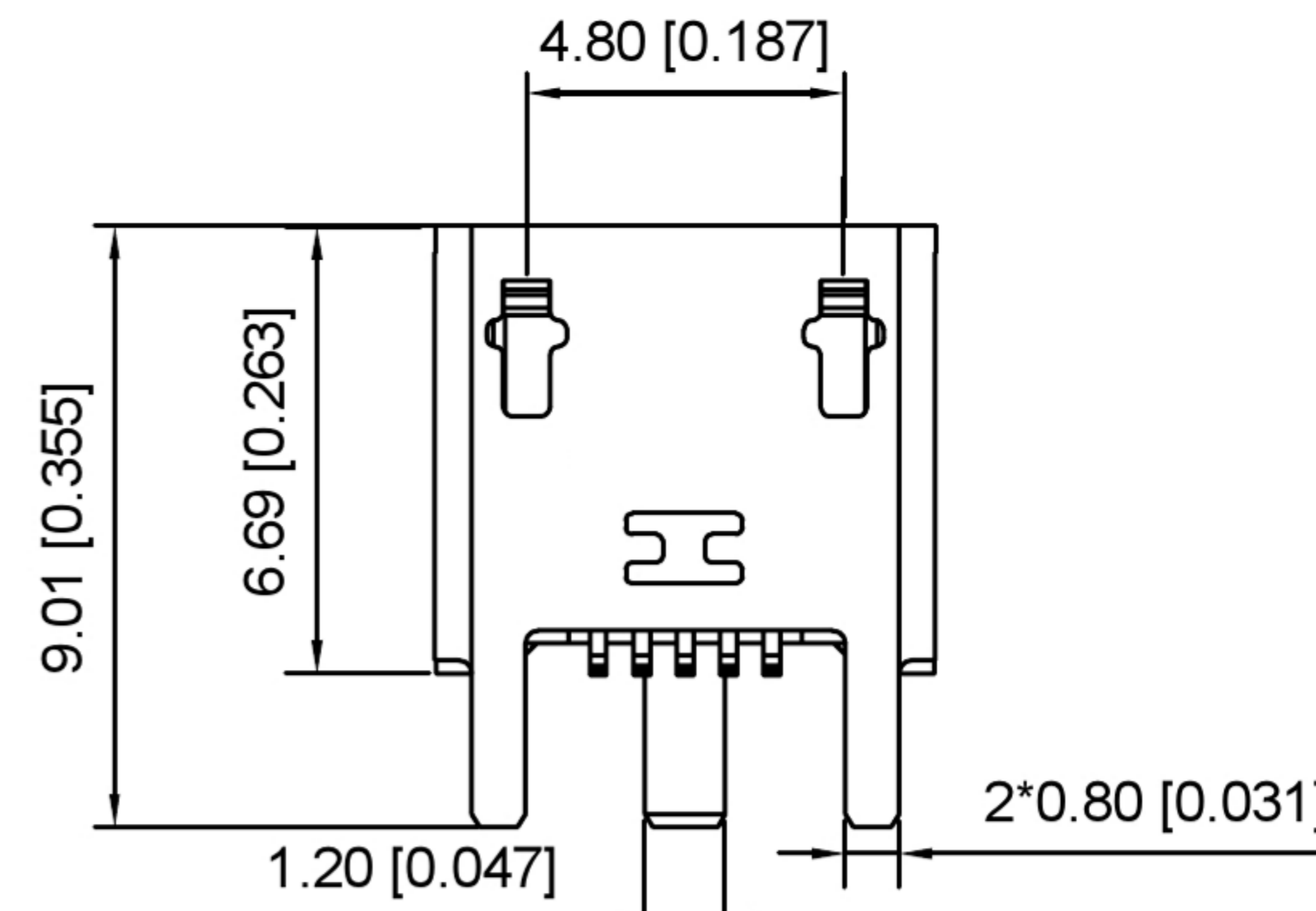
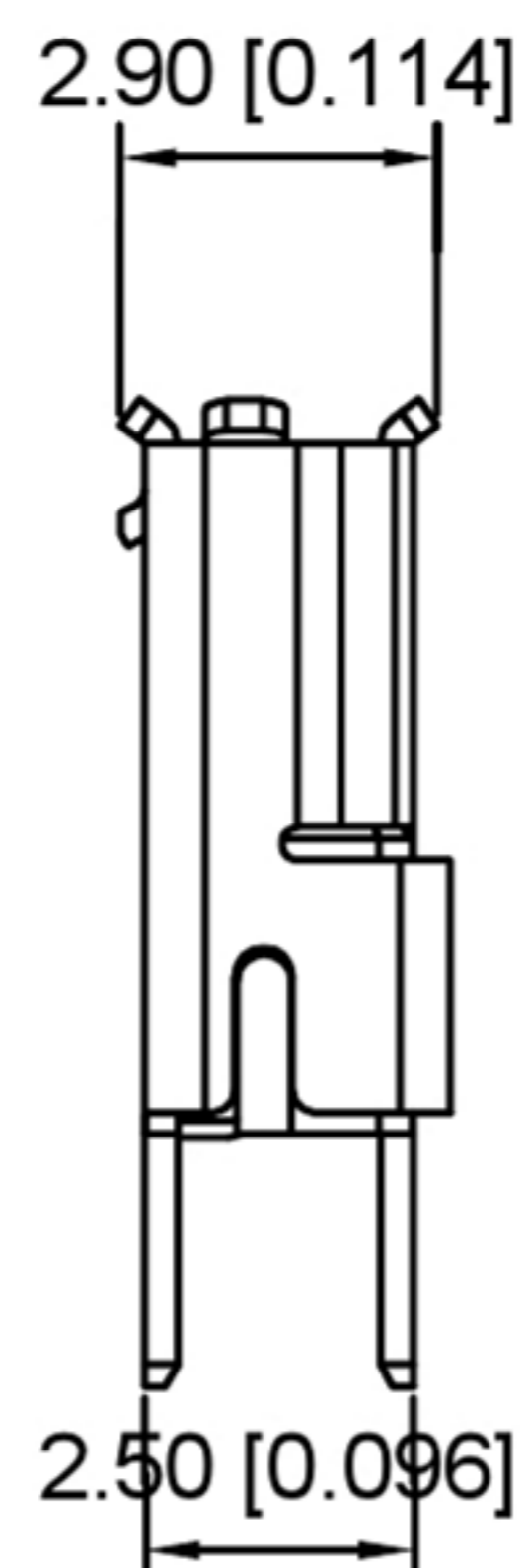
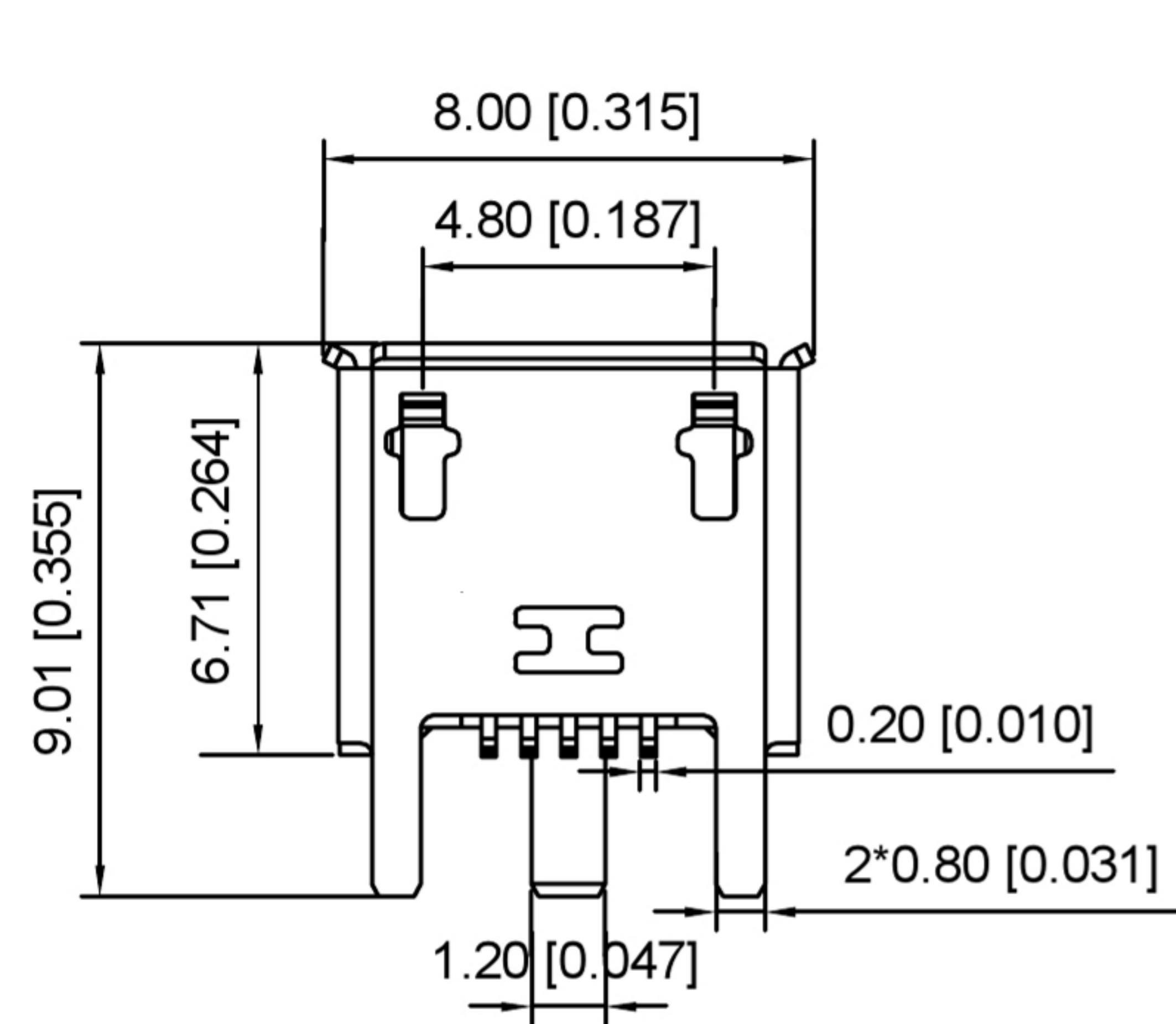

F: Flat

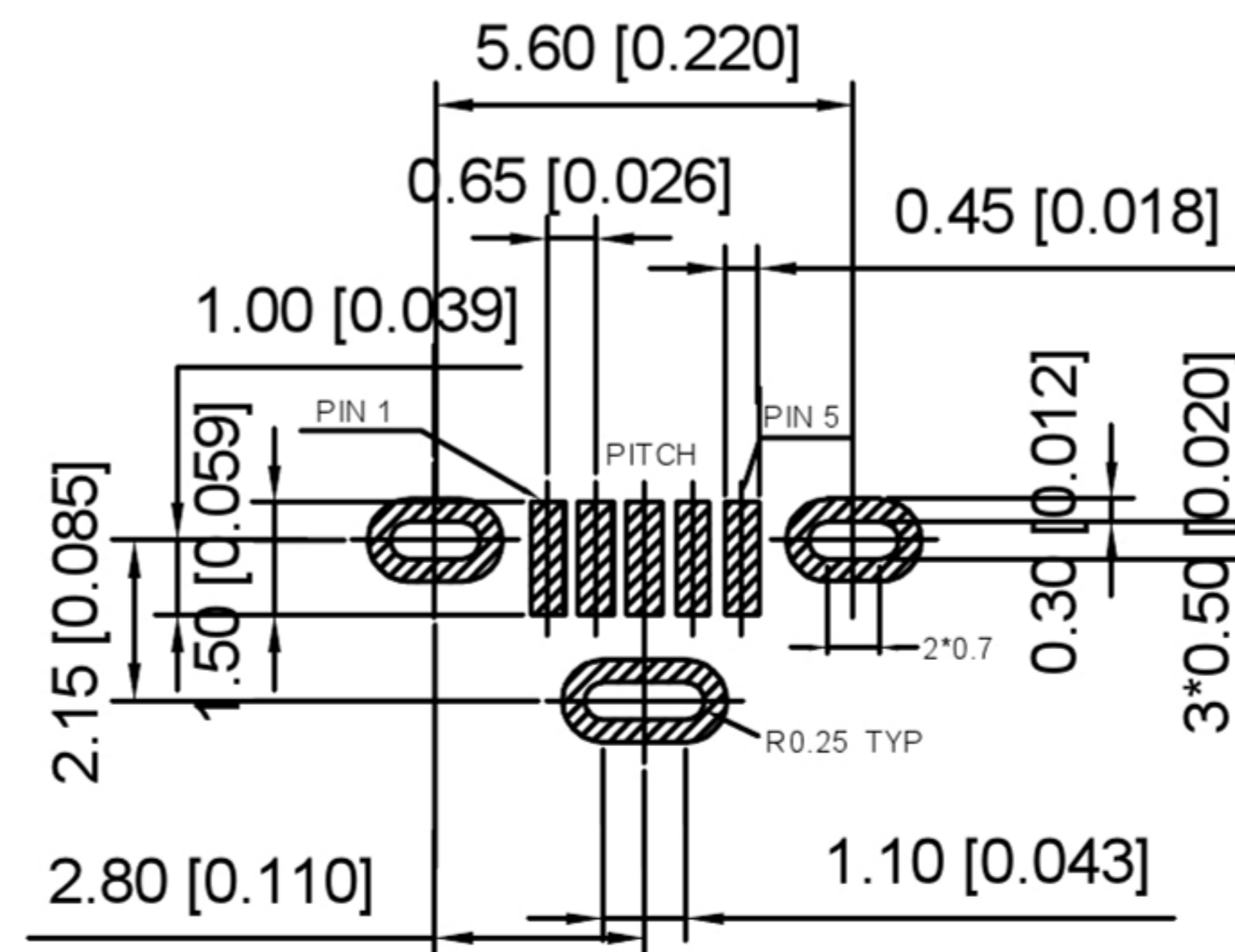
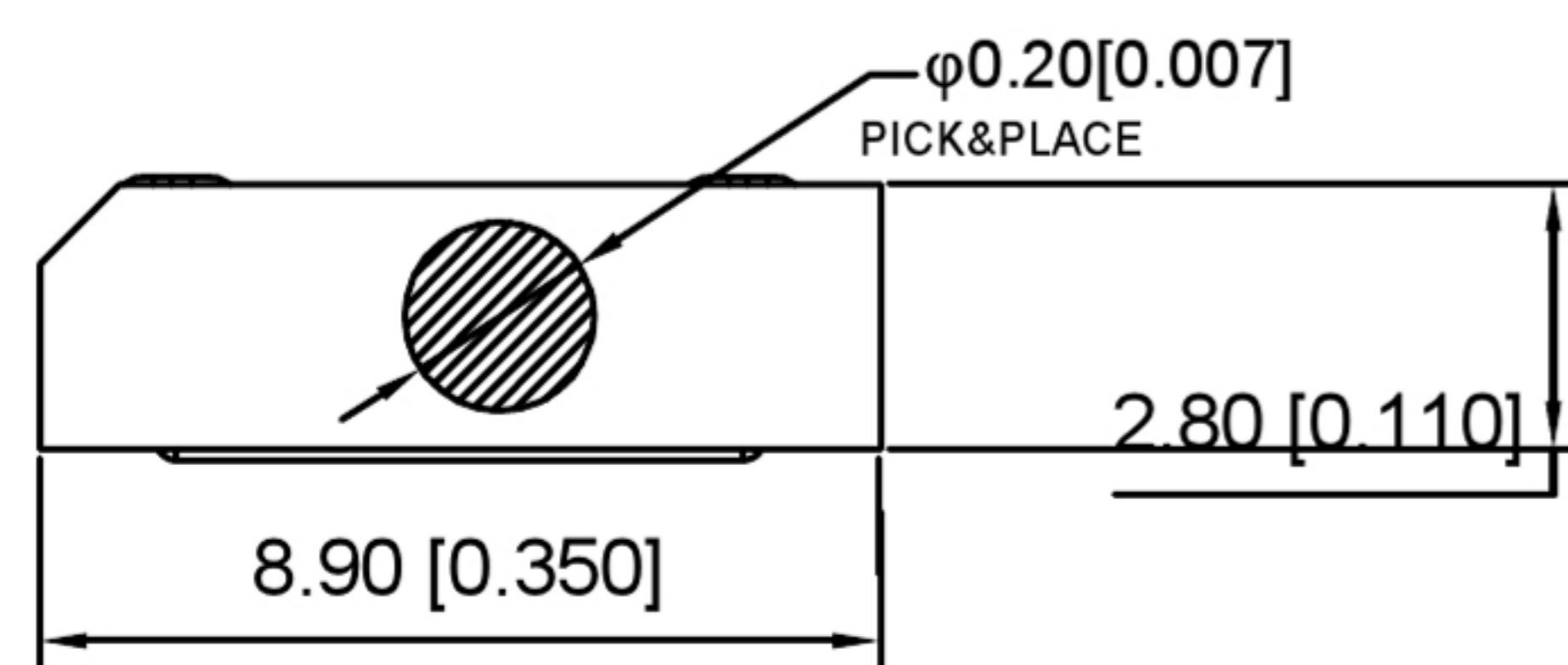

RECOMMEND PCB LAYOUT (THICKNESS=1.6mm)
TOLERANCE: ±0.05

Notes:

- Specifications:
1. Current rating: 1 A Max.
 2. Dielectric withstanding.voltage: 100V(AC) for 1 min.
 3. Contact resistance: 50m Ω Max.
 4. Insulation resistance: 100M Ω Min.
 5. Total mating force: 3.57 Kgf Max.
 6. Total unmating force: 1.0 Kgf Min.0.81~2.05 Kgf Min.after 10000 insertion/extraction cycles
 7. Temperature range: -30°C~+80°C

Housing Material: LCP UL94V-0, black
Contact Terminal: PHOSPHOR BRONZE
Metallic Shell: SUS

DSND		SCALE: N/A	MODEL TYPE: MICRO USB		
DWN		VIEW:	PART NO.:		
CHKD		UNIT: mm/in	DWG NO.:		
APPD		SIZE: A4	XB-U255-051N-4BH74		
REVISIONS		DATE	REVISED	APPROVED	UNSPECIFIED TOLERANCES
www.alpsr.com www.gdxjdz.com www.xbswitch.com					
					DONG GUAN XI BANG ELECTRONIC CO., LTD
					WEIGHT SHEET REVISION
					1/1 A0

