

Notes:

1. Dimension shall be interpreted per ASME Y14.5 M1994.
2. Dimension marked ▽ & ▼ should be checked by Q.C. and process, engineers and ▽ should also check the CPK data.

Specification:

1. Current Rating: 1.5 A Max
2. Voltage Rating: 30V AC, DC
3. Dielectric Strength: 100V AC RMS for 1 minute.
4. Contact Resistance: 50 mΩ Max.
5. Insulator Resistance: 100M Ω Min.
6. Mating/Unmating cycles: 6000 cycles
7. Temperature: -30°C to +80°C

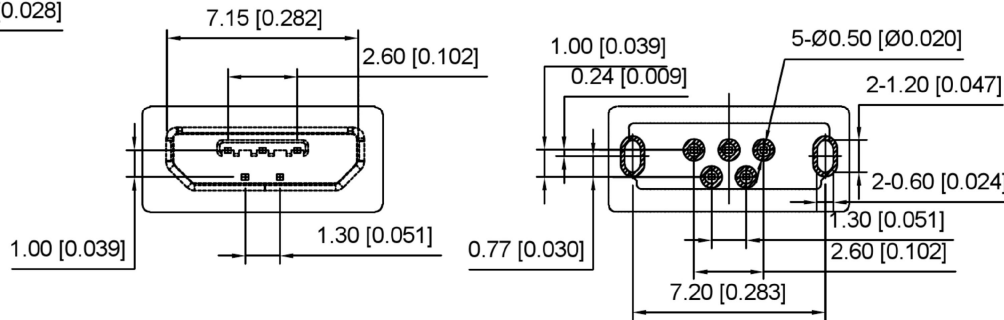
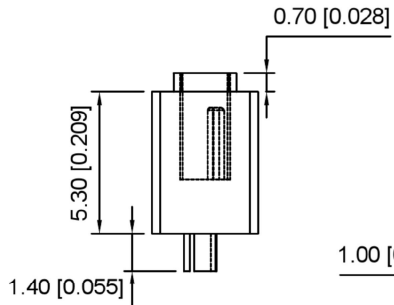
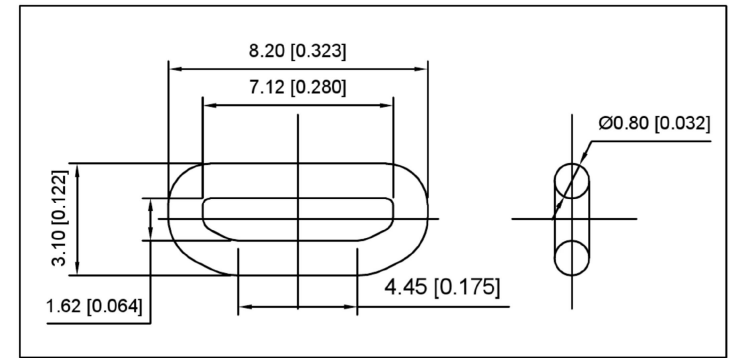
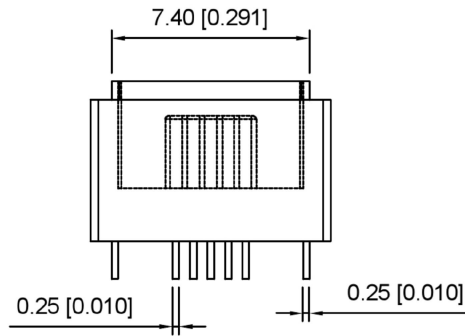
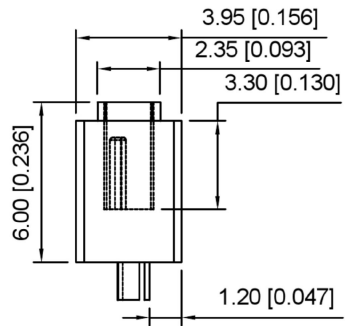

ITEM	PART NAME	QTY	MATERIAL	FINISHING
③	Shell	1	SUS	T=0.25mm
②	Contact	5	Copper alloy	T=0.2mm
①	Housing	1	HI-TEMP. PLASIC UL 94V-0	BLACK

REVISIONS	DATE	REVISED	APPROVED	UNSPECIFIED TOLERANCES
				ANGULAR ±5°
				L ≤ 4 ±0.2
				4 < L ≤ 16 ±0.3
				16 < L ≤ 63 ±0.4
				L > 63 ±0.5



DSND	SCALE: N/A	MODEL TYPE: MICRO USB
DWN	VIEW:	PART NO.:
CHKD	UNIT: mm/in	DWG NO.: U-E-M5SS-W-6
APPD	SIZE: A4	WEIGHT SHEET REVISION
DONG GUAN XI BANG ELECTRONIC CO., LTD		1/1 A0