

S:Scrolls

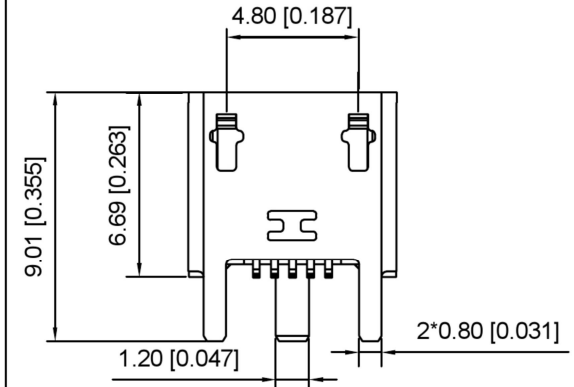

F: Flat

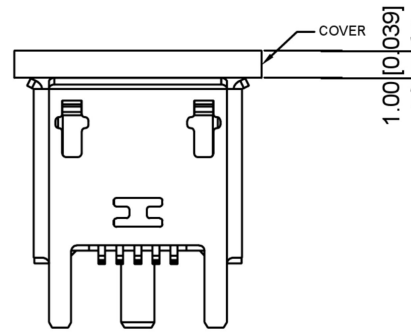
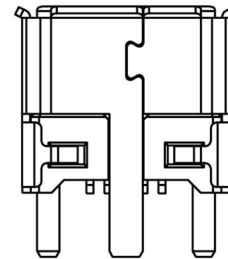
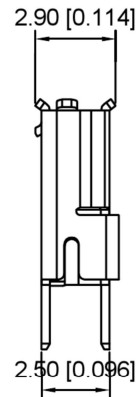
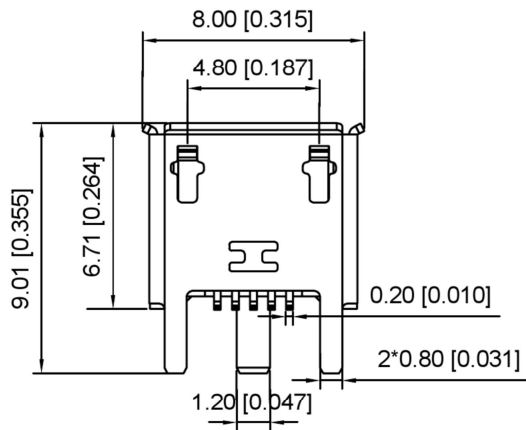

Notes:

Specifications:

1. Current rating: 1 A Max.
2. Dielectric withstanding.voltage: 100V(AC) for 1 min.
3. Contact resistance: 50m Ω Max.
4. Insulation resistance: 100M Ω Min.
5. Total mating force: 3.57 Kgf Max.
6. Total unmating force: 1.0 Kgf Min.0.81~2.05 Kgf Min.after 10000 insertion/extraction cycles
7. Temperature range: -30°C~+80°C

Housing Material: LCP UL94V-0, black
Contact Terminal: PHOSPHOR BRONZE
Metallic Shell: SUS

U255-05XN-4BH74-XS

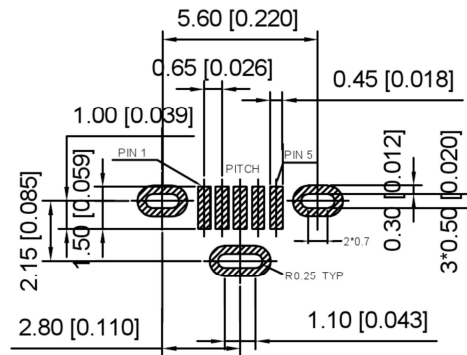
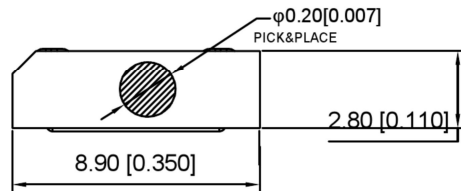
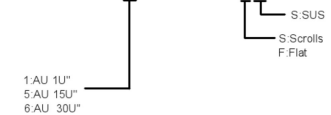

RECOMMEND PCB LAYOUT (THICKNESS=1.6mm)
TOLERANCE: ±0.05

				ANGULAR	±5°
				L ≤ 4	±0.2
				4 < L ≤ 16	±0.3
				16 < L ≤ 63	±0.4
				L > 63	±0.5
				UNSPECIFIED TOLERANCES	
REVISIONS	DATE	REVISED	APPROVED		
www.alpsr.com www.gdxjdz.com www.xbswitch.com					



DSND	SCALE: N/A	MODEL TYPE:	MICRO USB		
DWN	VIEW:	PART NO.:			
CHKD	UNIT: mm/in	DWG NO.:	U255-05XN-4BH74-XS		
APPD	SIZE: A4	WEIGHT	SHEET	REVISION	
			1/1	A0	

DONG GUAN XI BANG ELECTRONIC CO., LTD