

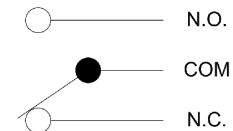

CAD FILE:

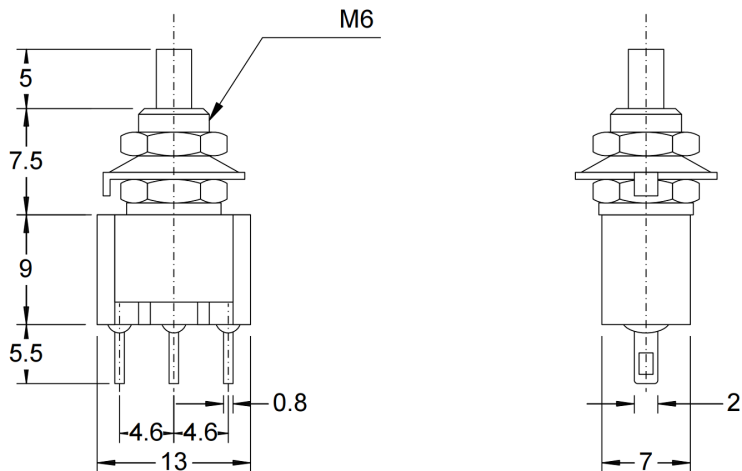

SCHEMATIC

SPECIFICATIONS

CONTACT RATING	: 5A with resistive load @ 120 VAC or 28 VDC.
ELECTRICAL LIFE	: 50,000 make-and-break cycles at full load.
CONTACT RESISTANCE	: 10mΩ max. initial @ 2.4 VDC. 100mA for both coin silver and gold plated contacts.
INSULATION RESISTANCE	: 1,000MΩ min.
DIELECTRIC STRENGTH	: 1,000V RMS @ sea level.
OPERATING TEMPERATURE	: -30°C to 130°C.

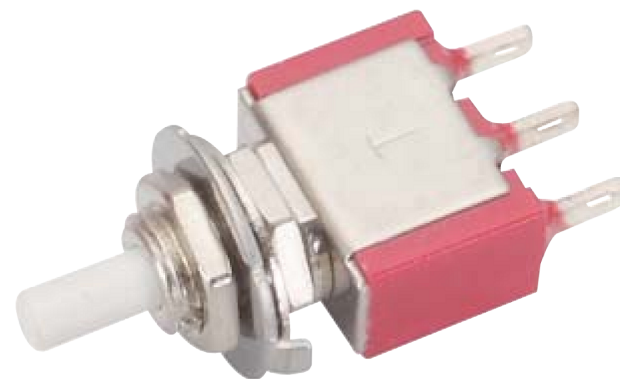

注：“*”表示关键尺寸(4个).

NO.	PARTS	MATERIALS	Q'TY	FINISH	TOLERANCE UNLESS SPECIFIED	ISSUE	DATE	DESCRIPTIONS OF REVISION	APPD.		
8											
7											
6					WITHIN 1.5mm : ±0.1mm	A	2012-9-25	初版	ZENQ. CHEN		
5					OVER 1.5mm : ±0.2mm	ISSUE	DATE	DESCRIPTIONS OF REVISION	APPD.		
4	CONTACT	SUS	1	Ag CLAD	TITLE : Button switch			UNIT : mm	DRWG NO.: XB-PB-001		
3	CASE	PPA/BRASS SRTIP	1	BLACK/Ag PLATED	MODEI :			SCALE: 5:1	DWN.	JUN. YANG	2012-9-25
2	COVER	STEEL STRIP	1	Ni PLATED					CHK'D	DONG. PANG	2012-9-25
1	KNOB	PPA	1	BLACK					APPD.	ZENQ. CHEN	2012-9-25
					东莞市溪榜电子有限公司 DONG GUAN XI BANG ELECTRONI CS CO., LTD.						