

TOP VIEW

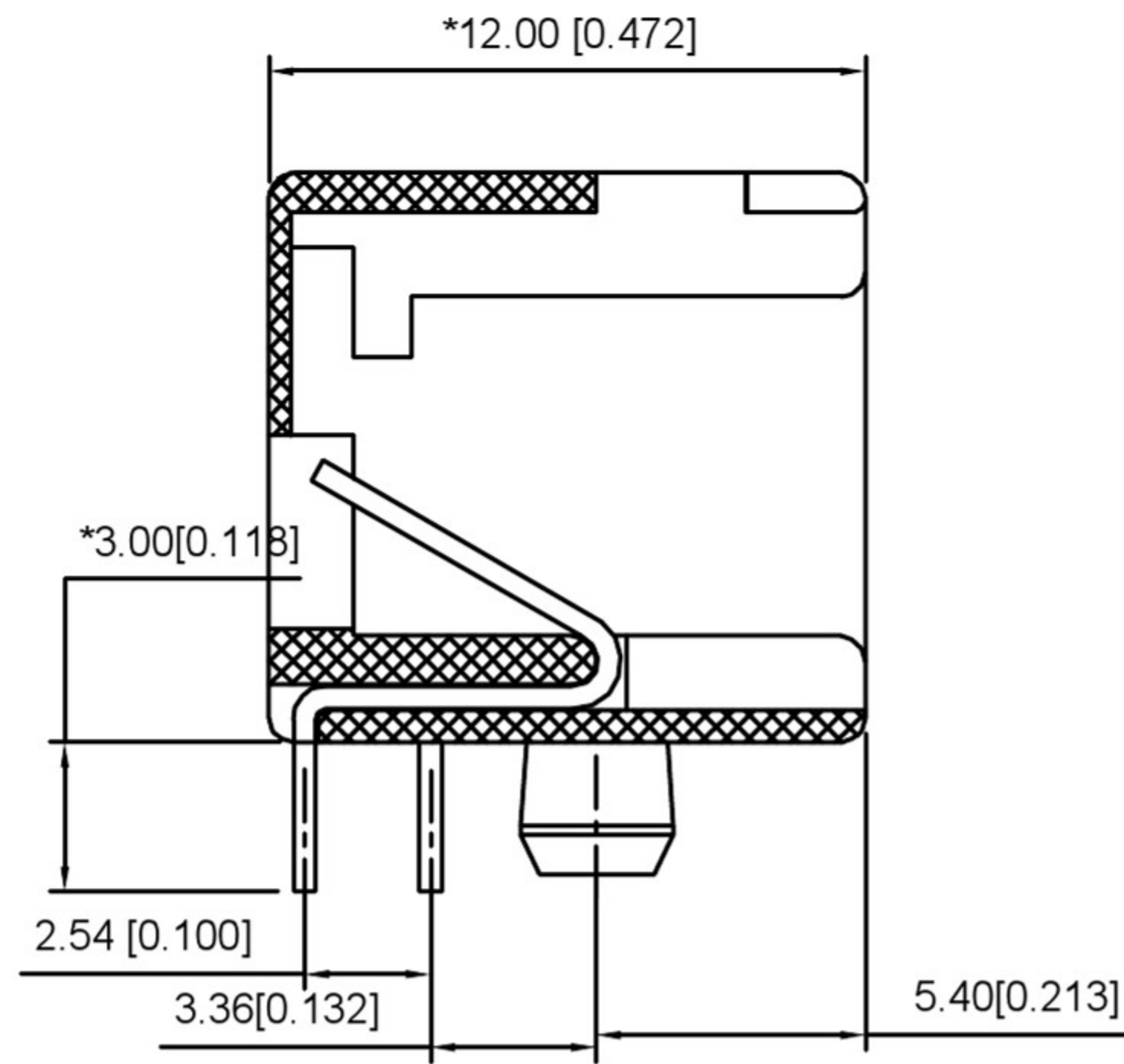

CUTAWAY VIEW

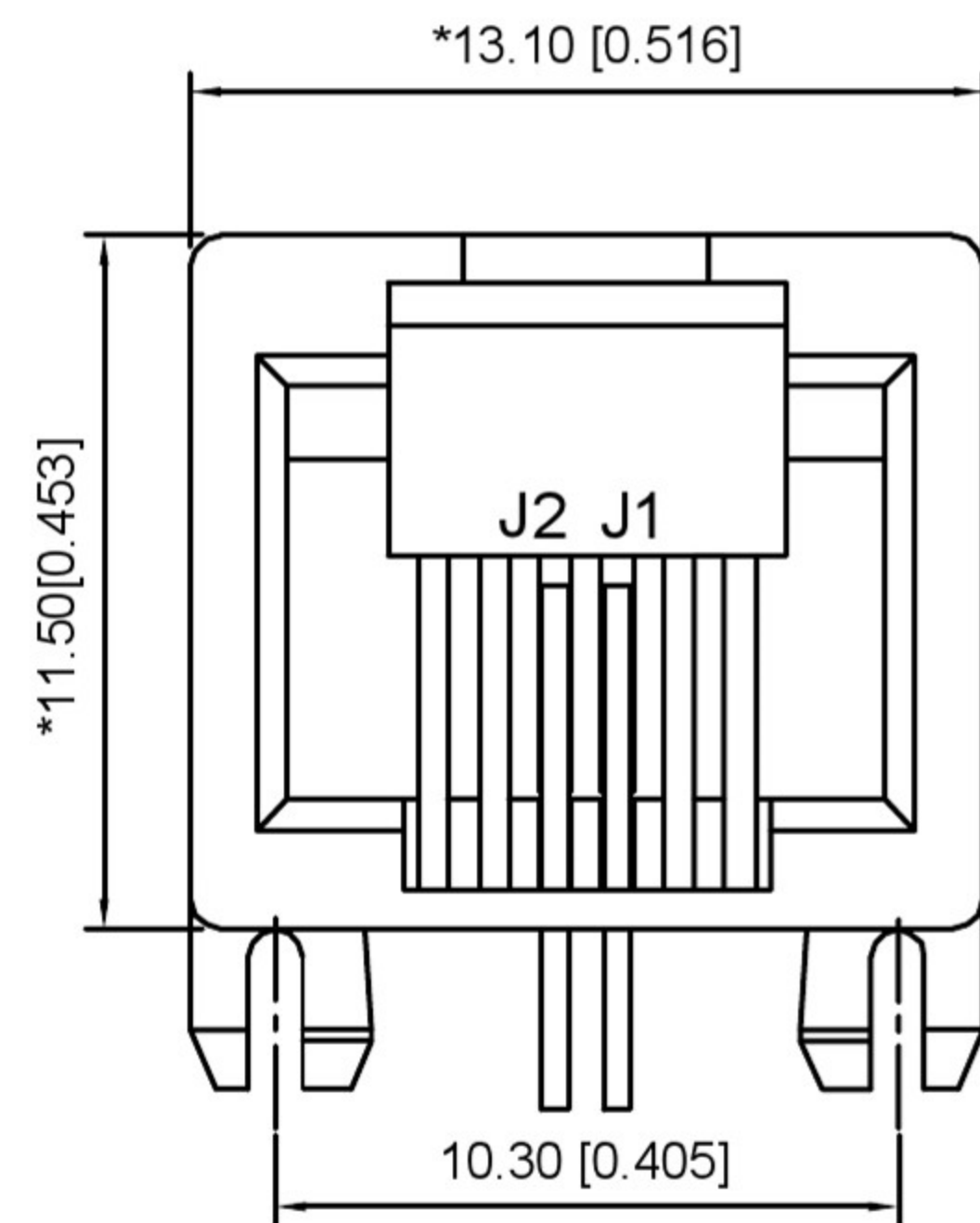

FRONT VIEW

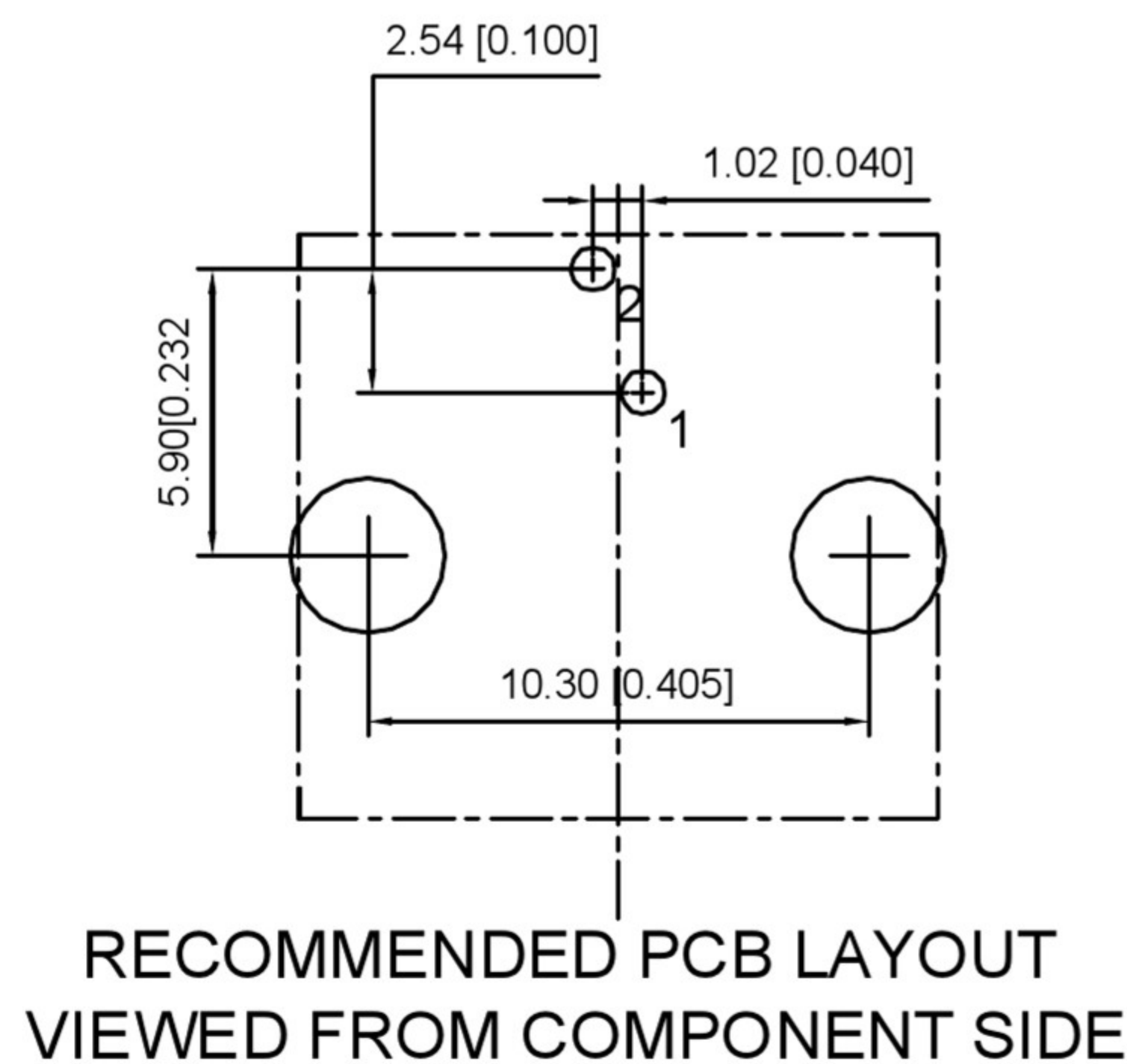

RECOMMENDED PCB LAYOUT
VIEWED FROM COMPONENT SIDE

MATERIAL 材料:

HOUSING 外壳: PBT,UL94V-0,BLACK.

TERMINAL 端子: PHOSPHOR BRONZE Ø=0.46MM, GOLD PLATING

MECHANICAL 机械:

DURABILITY 耐用性: 750 CYCLES MIN,12.5MM/MINUTE.

INSERTION FORCE 插入力:2.2KG.F MAX

RETENTION STRENGTH 保持力:7.7KG.F BETWEEN JACK AND PLUG.

OPERATING TEMPERATURE 工作温度: -40°C~+85°C.

STORAGE TEMPERATURE 储存温度: -40°C~+85°C.

ALL CRITICAL DIMENSIONS WITH ""

ELECTRICAL 电气:

VOLTAGE 电压: 125 VOLTS AC.



CURRENT RATING 电流额定值: 1.5AMP.

DIELECTRIC STRENGTH 介电强度: 1000 VAC RMS 50HZ OR 60HZ,1 MIN

INSULATION RESISTANCE 绝缘电阻: 500 MEGA OHMS MIN.INITIAL
AFTER 500V DC FOR 1 MINUTE.

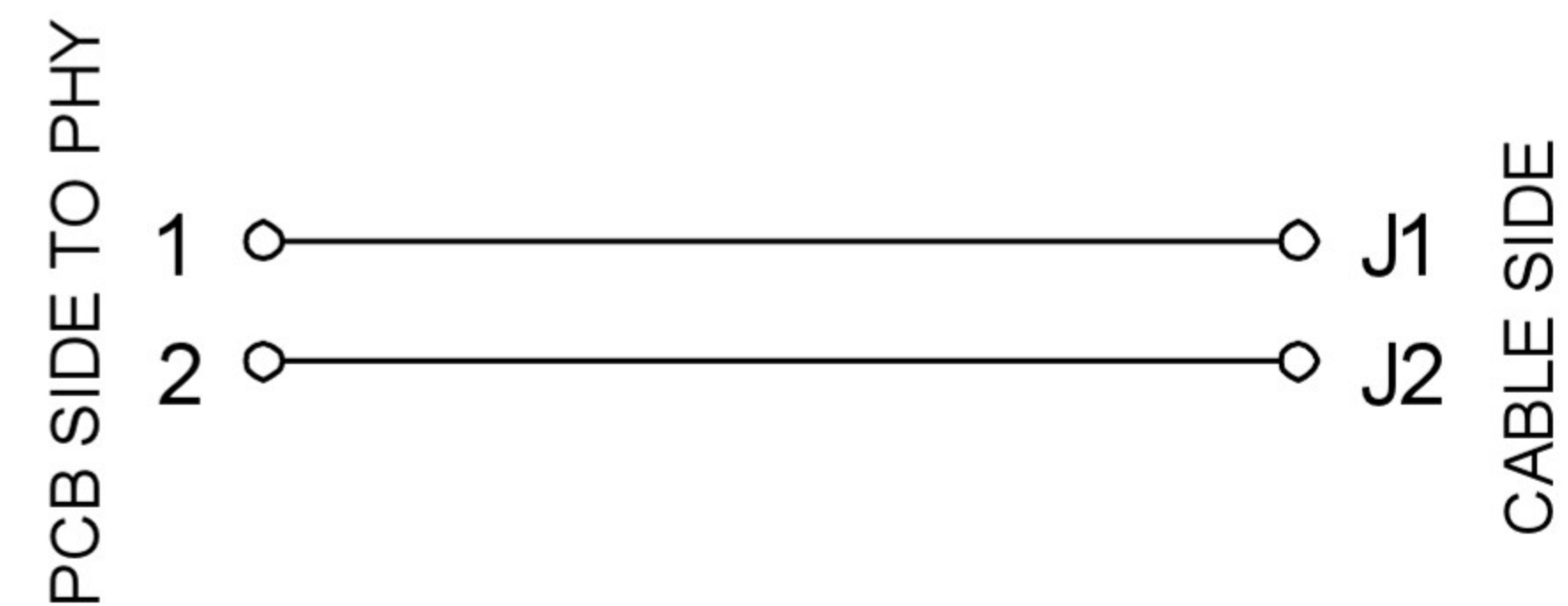
CONTACT RESISTANCE 接触电阻:SINGLE TERMINAL 30 MILLIOHMS MAX.
INITIAL 50 MILLIOHMS MAX. AFTER
DURABILITY TEST.



				ANGLAR	±5°		DSND	SCALE: N/A	MODEL TYPE: RJ11		
				L ≤ 4	±0.2		DWN	VIEW: 	PART NO.:		
				4 < L ≤ 16	±0.3		CHKD	UNIT: mm/in	DWG NO.:		
				16 < L ≤ 63	±0.4		APPD	SIZE: A4	XB-X10AJIWA1DY1006		
				L > 63	±0.5	DONG GUAN XI BANG ELECTRONIC CO., LTD			WEIGHT	SHEET	REVISION
REVISIONS				UNSPECIFIED TOLERANCES						1/1	A0
www.alpsr.com www.gdxjdz.com www.xbswitch.com											