

FRONT VIEW

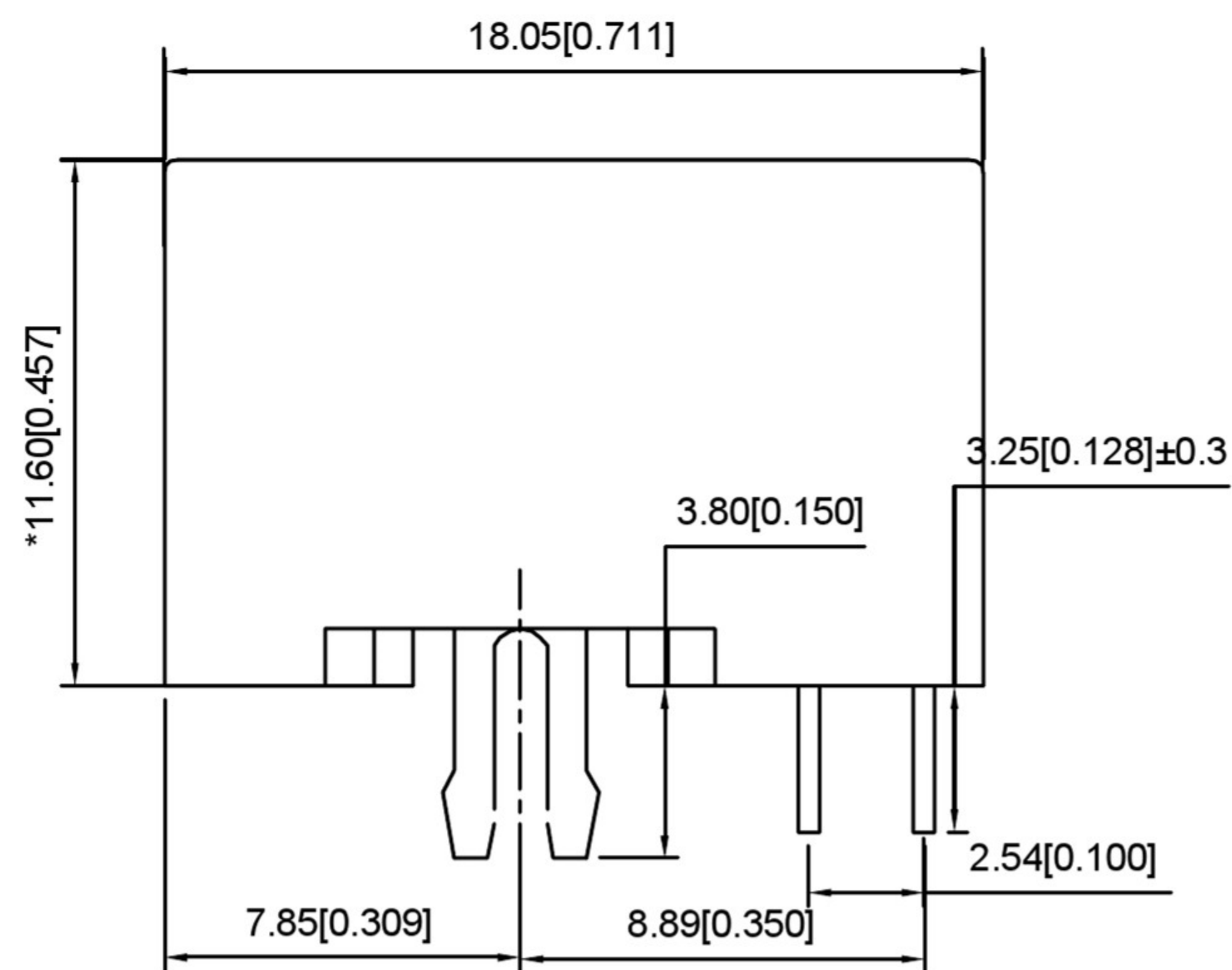

RIGHT SIDE VIEW

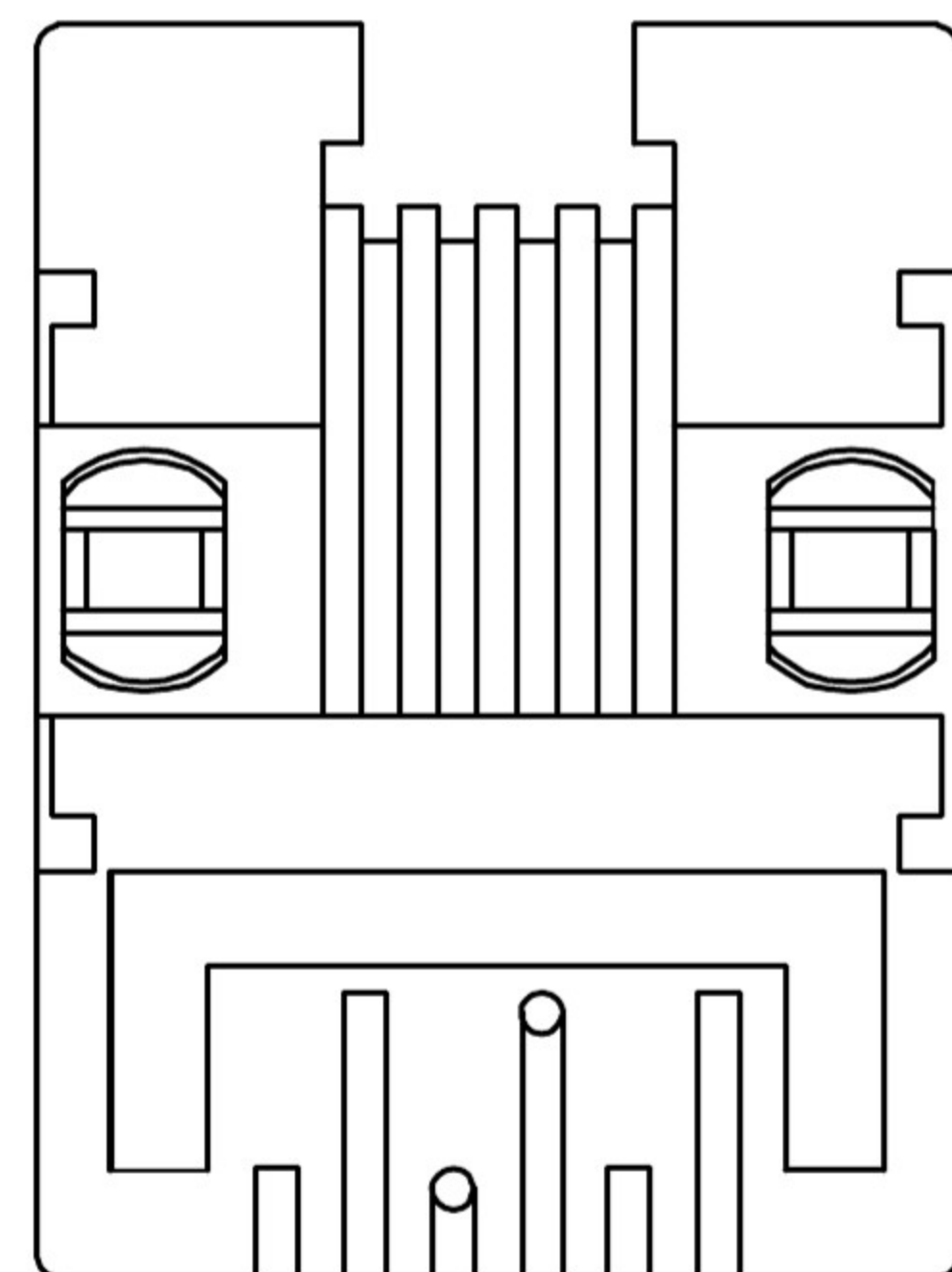

BOTTOM VIEW

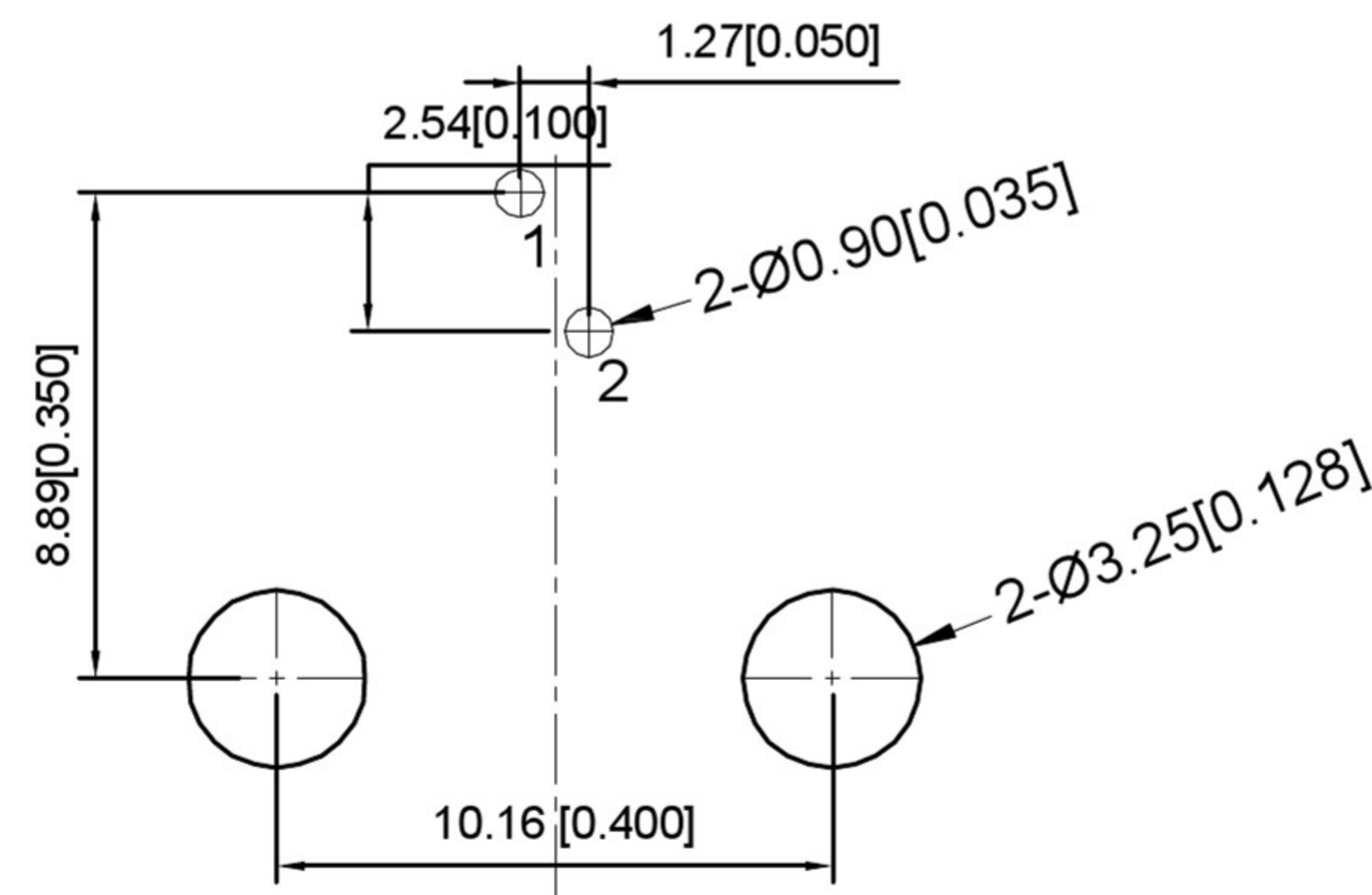

RECOMMENDED PCB LAYOUT
VIEWED FROM COMPONENT SIDE

MATERIAL 材料:

HOUSING 外壳: PBT,UL94V-0,BLACK.

TERMINAL 端子: PHOSPHOR BRONZE Ø=0.46MM, GOLD PLATING

MECHANICAL 机械:

DURABILITY 耐用性: 750 CYCLES MIN, 12.5MM/MINUTE.

INSERTION FORCE 插入力: 2.2KG.F MAX

RETENTION STRENGTH 保持力: 7.7KG.F BETWEEN JACK AND PLUG.

OPERATING TEMPERATURE 工作温度: -40°C~+85°C.

STORAGE TEMPERATURE 储存温度: -40°C~+85°C.

ALL CRITICAL DIMENSIONS WITH "**"

ELECTRICAL 电气:

VOLTAGE 电压: 125 VOLTS AC.

CURRENT RATING 电流额定值: 1.5AMP.

DIELECTRIC STRENGTH 介电强度: 1000 VAC RMS 50HZ OR 60HZ, 1 MIN



INSULATION RESISTANCE 绝缘电阻: 500 MEGA OHMS MIN. INITIAL
AFTER 500V DC FOR 1 MINUTE.

CONTACT RESISTANCE 接触电阻: SINGLE TERMINAL 30 MILLIOHMS MAX.
INITIAL 50 MILLIOHMS MAX. AFTER
DURABILITY TEST.

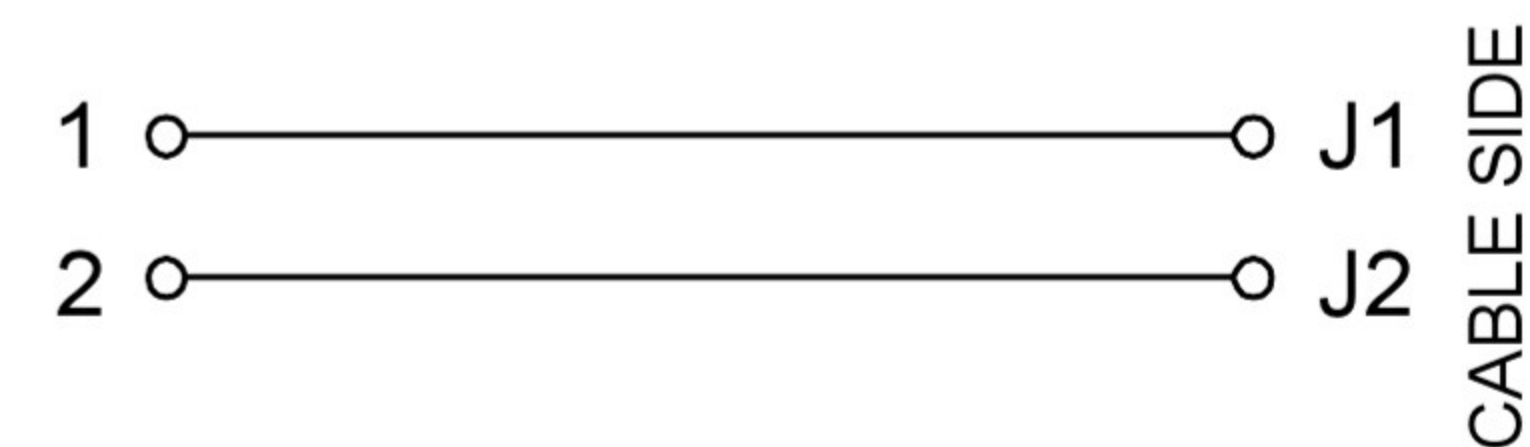
PCB SIDE TO PHY



CABLE SIDE

				ANGULAR	±5°		DSND	SCALE: N/A	MODEL TYPE: RJ11
				L ≤ 4	±0.2		DWN	VIEW: 	PART NO.:
				4 < L ≤ 16	±0.3		CHKD	UNIT: mm/in	DWG NO.:
				16 < L ≤ 63	±0.4		APPD	SIZE: A4	XB-X08AJIWA1DY3017
				L > 63	±0.5	DONG GUAN XI BANG ELECTRONIC CO., LTD			WEIGHT
REVISIONS				UNSPECIFIED TOLERANCES			SHEET		
www.alpsr.com www.gdxjdz.com www.xbswitch.com							1/1		
							REVISION		
							A0		