

CAD FILE:

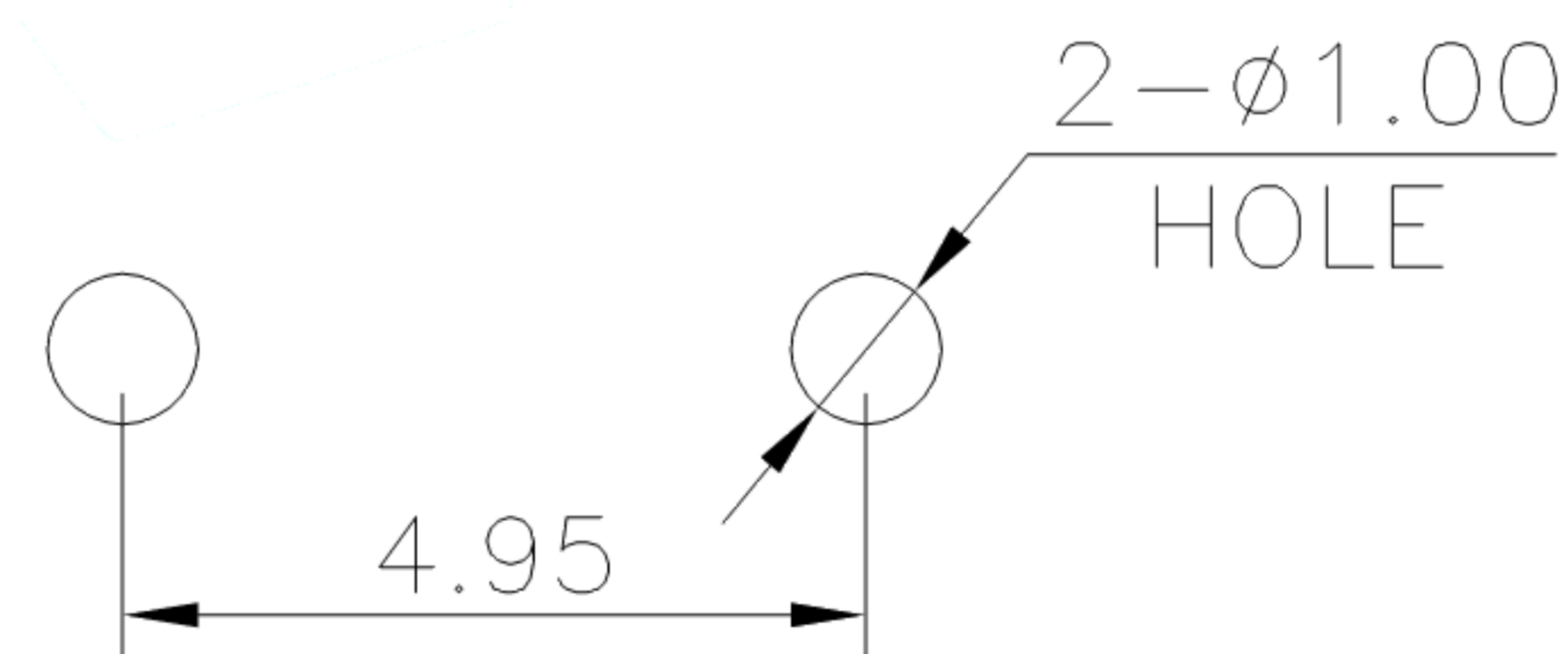

PCB Layout(Pattern side)

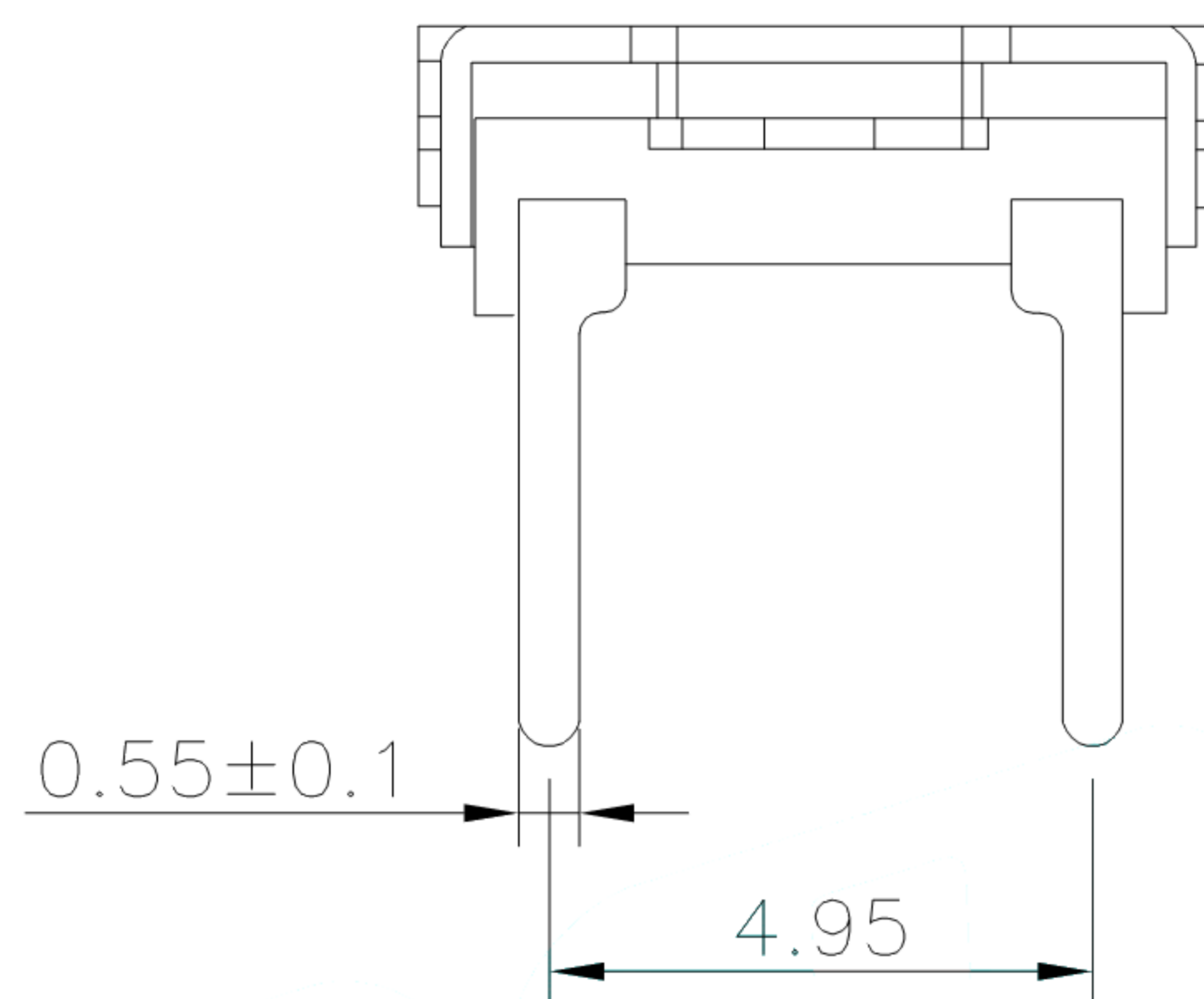
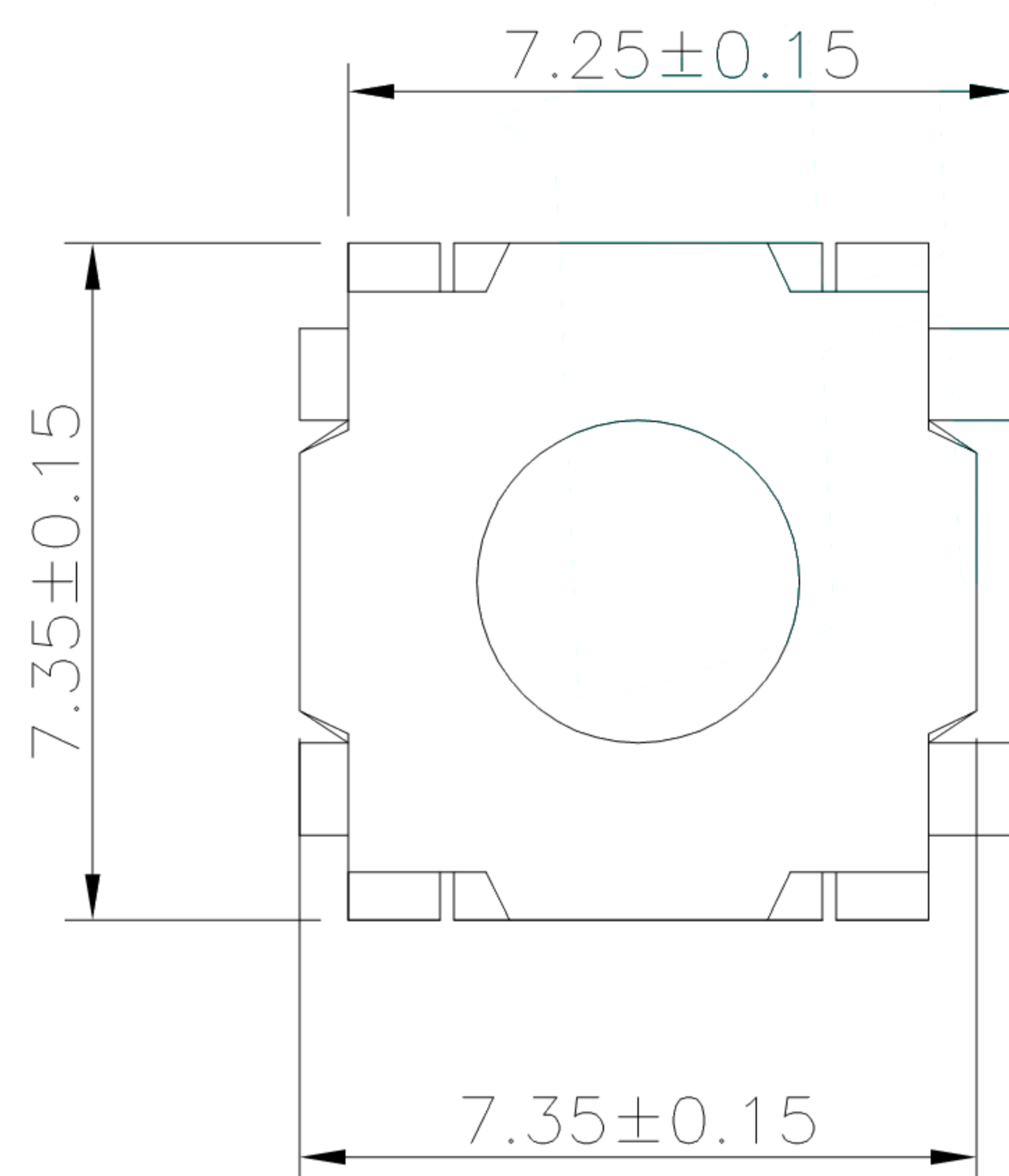
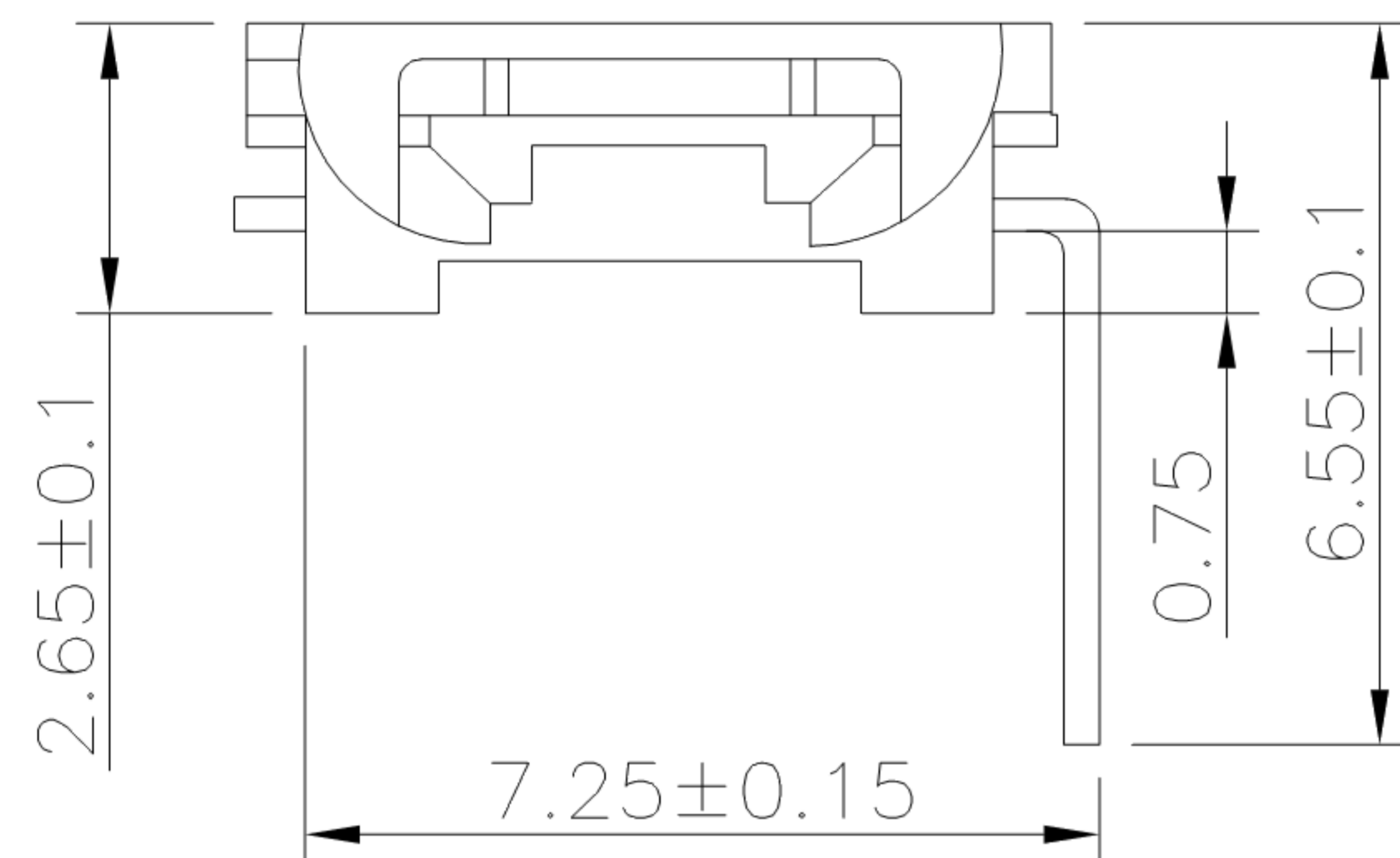
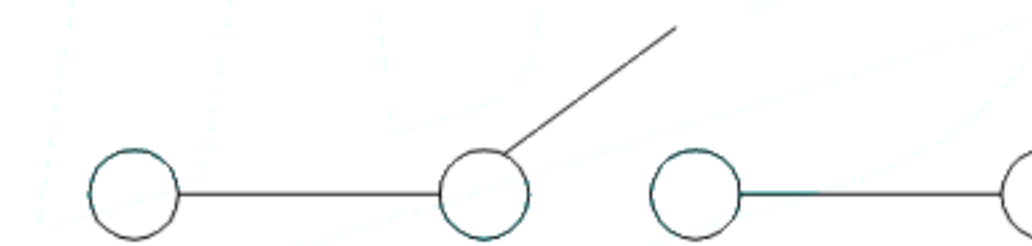

SCHEMATIC

| | |
|---------|--------|
| NO.2 | |
| PART NO | VIGOR |
| 3 | 180±40 |

| | |
|-----------|---------------|
| NO.4-NO.5 | |
| PART NO | NOTE |
| 01~99 | SERIAL NUMBER |

- Typical Specifications
- 1.Rating : DC 12V 50mA
 - 2.Contact Resistance: $\leq 100m\Omega$
 - 3.Insulation Resistance: $\geq 100m\Omega$ DC250V
 - 4.Travel: $0.3\pm 0.1mm$
 - 5.Life : 100,000 Cycles

| | | | | | | | | | | | |
|-----|---------|-----------------|------|-----------------|---------------------------------------------------------------|-------|-----------|--------------------------|-------------------------------|------------|-----------|
| 8 | | | | | TOLERANCE | | | | | | |
| 7 | | | | | UNLESS SPECIFIED | | | | | | |
| 6 | | | | | WITHIN 1.5mm : $\pm 0.1mm$ | A | 2012-9-25 | 初版 | | ZENQ. CHEN | |
| 5 | | | | | OVER 1.5mm : $\pm 0.2mm$ | ISSUE | DATE | DESCRIPTIONS OF REVISION | | APPD. | |
| 4 | CONTACT | SUS | 1 | Ag CLAD | TITLE : TACT SWITCH | | | UNIT : mm | DRWG NO.: XB-TS-1843DF | | |
| 3 | CASE | PPA/BRASS SRTIP | 1 | BLACK/Ag PLATED | MODEL: | | | SCALE: 5:1 | DWN. | JUN. YANG | 2012-9-25 |
| 2 | COVER | STEEL STRIP | 1 | Ni PLATED | 东莞市溪榜电子有限公司 DONG GUAN XI BANG ELECTRONICS CO., LTD. | | | CHK'D | DONG. PANG | 2012-9-25 | |
| 1 | KNOB | PPA | 1 | BLACK | | | | APPD. | ZENQ. CHEN | 2012-9-25 | |
| NO. | PARTS | MATERIALS | Q'TY | FINISH | | | | | | | |