

CAD FILE:

**ROHS**

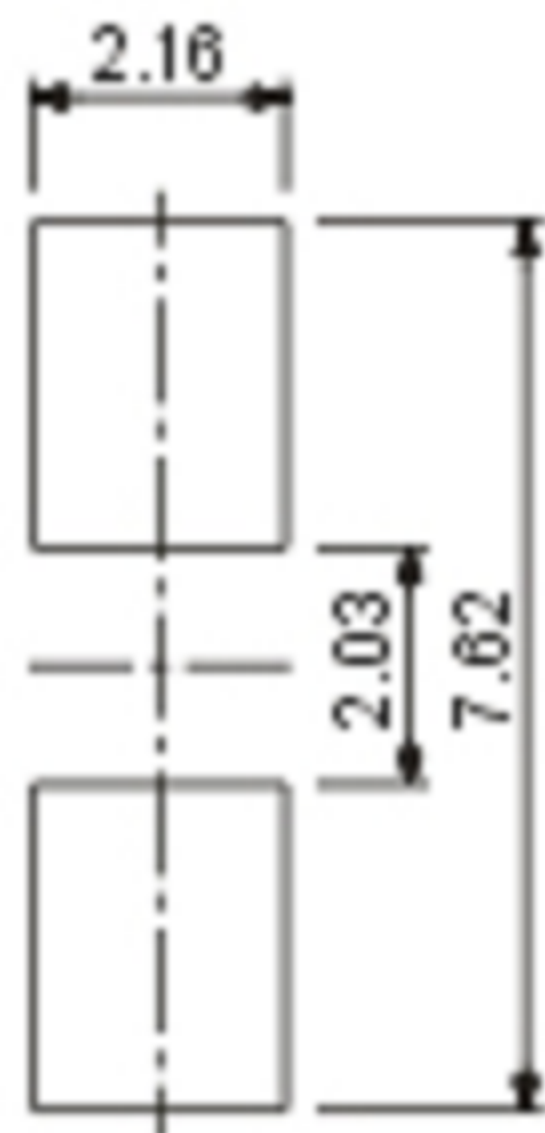

P.C.B LAND DIMENSION

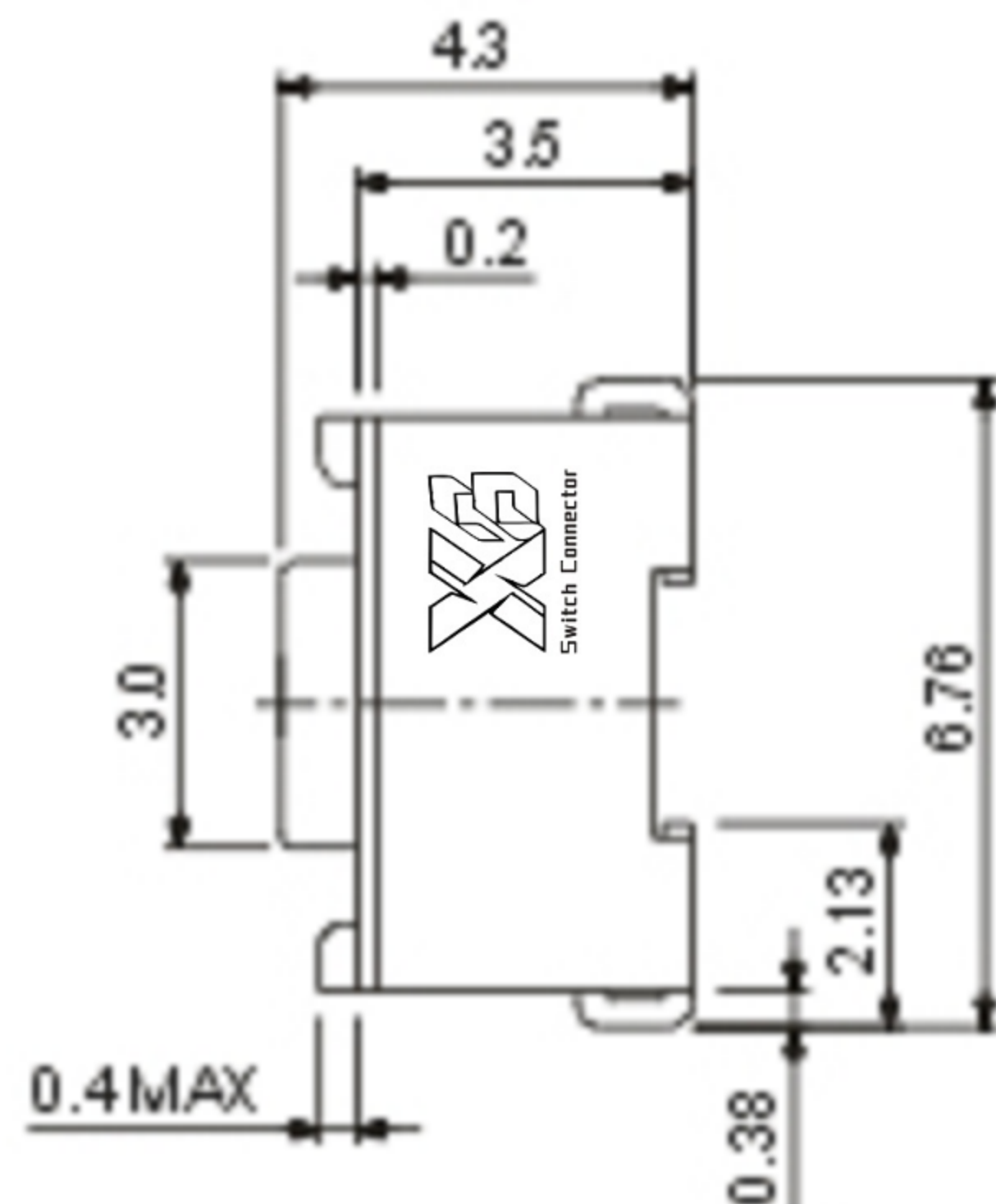
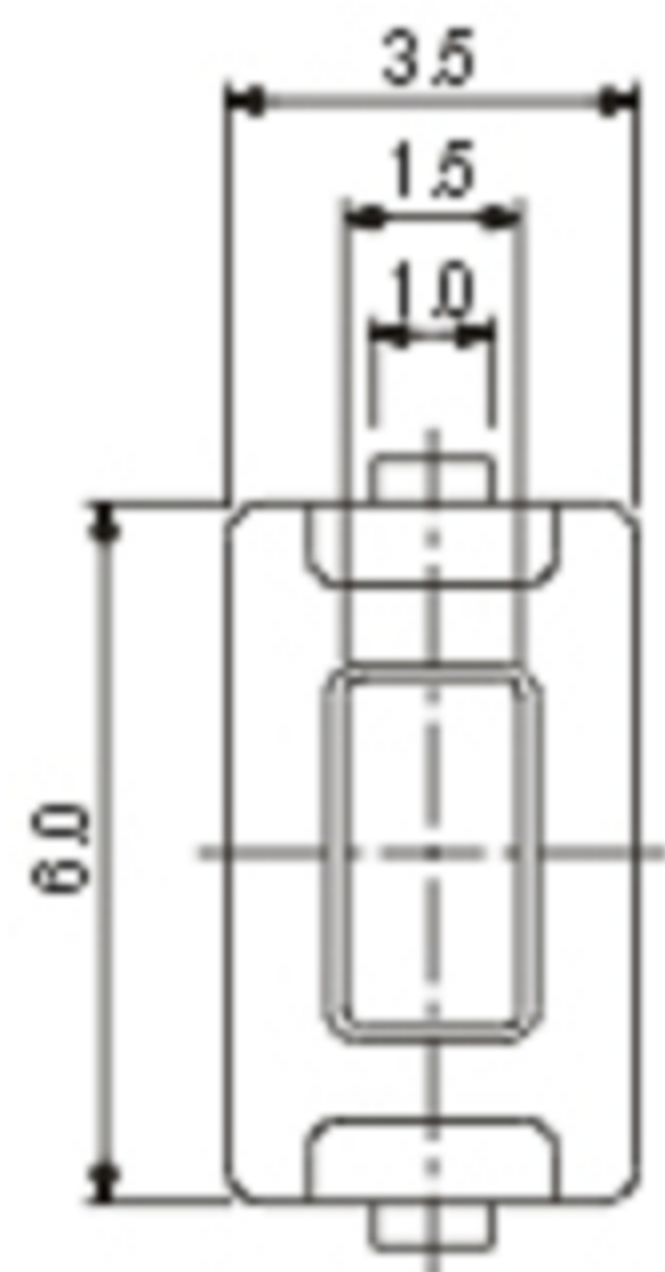

CIRCUIT DIAGRAM

1. Contact : Mechanical Contact
2. Travel : 0.25±mm
3. Operating Force : 160±50gf 250±50gf
4. Life : 100,000 Cycles Min.
5. Contact Resistance : 30mΩ Max.
6. Stem Color:Black
7. L:4.3 5.0

NO.	PARTS	MATERIALS	Q'TY	FINISH	TOLERANCE UNLESS SPECIFIED	ISSUE	DATE	DESCRIPTIONS OF REVISION	APPD.
8									
7									
6					WITHIN 1.5mm : ±0.1mm	A	2012-9-25	初版	ZENQ. CHEN
5					OVER 1.5mm : ±0.2mm	ISSUE	DATE	DESCRIPTIONS OF REVISION	APPD.
4	CONTACT	SUS	1	Ag CLAD	TITLE : Tact Switch			UNIT : mm	DRWG NO.: XB-TS-1143
3	CASE	PPA/BRASS SRTIP	1	BLACK/Ag PLATED	MODEL: XB-TS-1143			SCALE: 5:1	DWN. JUN. YANG 2012-9-25
2	COVER	STEEL STRIP	1	Ni PLATED	<b>东莞市溪榜电子有限公司</b> DONG GUAN XI BANG ELECTRONI CS CO., LTD.			CHK'D	DONG. PANG 2012-9-25
1	KNOB	PPA	1	BLACK				APPD.	ZENQ. CHEN 2012-9-25