

凸柄(P)

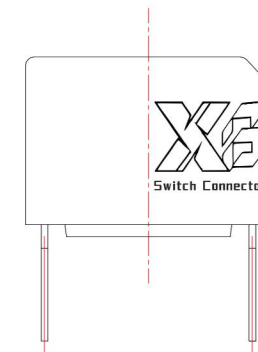

短柄(S)

$$B \pm 0.1 = 2.54 \times (P - 1)$$

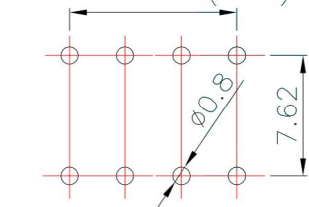

PCB Layout(Pattern Side)

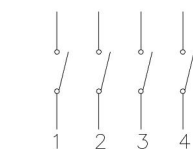
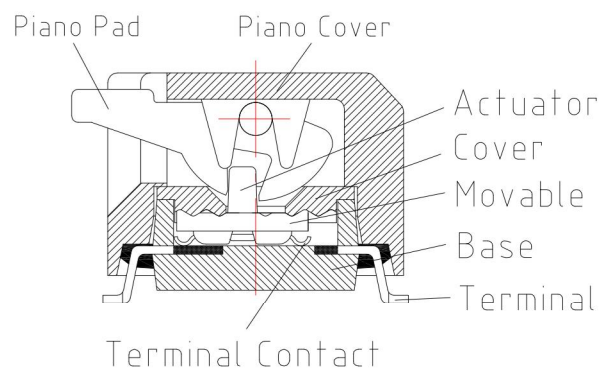

Circuit Diagram

Poles(N)	A (mm)
01	3.96
02	6.48
03	9.02
04	11.56
05	14.10
06	16.64
07	19.18
08	21.72
09	24.26
10	26.80
12	31.88

Part Name	Material	Finished
Piano Pad	PA46 UL94 V0	White
Piano Cover	PPS UL94 V0	Black
Base	PPS UL94 V0	Black
Cover	PPS UL94 V0	Black
Actuator	PA46 UL94 V0	White
Movable	Phosphor Bronze	Gold
Terminal Contact	Brass	Gold
Terminal	Brass	Gold

DSND	SCALE: N/A	MODEL TYPE: DIP SWITCH
DWN	VIEW:	PART NO.: DS-XX-X-X
CHKD	UNIT: mm/in	DWG NO.:
APPD	SIZE: A4	
		WEIGHT
		SHEET
		REVISIC
		1/1
		A0



DONG GUAN XI BANG ELECTRONIC CO., LTD

ANGULAR	±5°
L ≤ 4	±0.2
4 < L ≤ 16	±0.3
16 < L ≤ 63	±0.4
L > 63	±0.5
UNSPECIFIED TOLERANCES	

DATE	REVISED	APPROVED
------	---------	----------