

FREE

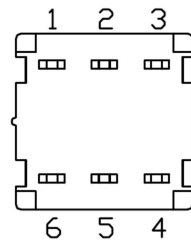

PUSH

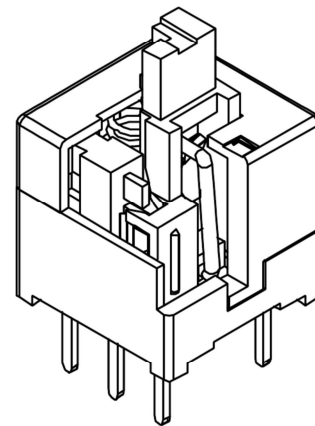
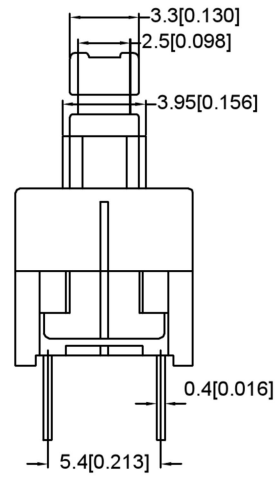
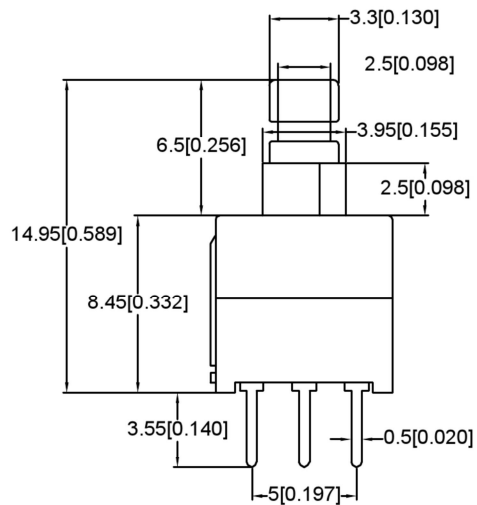

## FEATURES

- Light operating force.
- Long term low contact resistance.
- Momentary or latching operation.
- Short stroke 2.0mm to latch.
- Compact spacing on PCB of 8.5mm.

## SPECIFICATIONS

### 1.ELECTRICAL

● Contact rating	0.1A, 30VDC
● Contact resistance	50mWMax.
● Insulation resistance	100MΩMin. at 250VDC
● Dielectric strength	250VAC Min. for 60 sec.

### 2.MECHANICAL AND ENVIRONMENTAL

● Temperature rating	Operating: -15 °C to +55 °C Storage: -25 °C to +65 °C
● Operation force	160±80gf
● Stroke	Lock Stroke: 2.0±0.2mm Full Stroke: 2.5±0.2mm
● Operating life	full load: 1x10 <sup>4</sup> cycles no load: 1x10 <sup>5</sup> cycles
● Contact form	DPDT

PAPT NO	XB8585-X-150
OPERATION	W:NO LOCK Z:LOCK

⑦	Contact	—	2	Phosphor bronze	Plating silvering	—
⑥	Terminal	—	6	Brass	Plating silvering	—
⑤	Spring	—	1	Sus	Natural	—
④	Base	—	1	Pbt		—
③	Crochet Needle	—	1	Sus	Natural	—
②	Cover	—	1	Pom		—
①	Keystake	—	1	Pom		—
ITEM	PAPT NAMF	TER,NO	QTY	MATERIAL	FINISHING	REMARK

				ANGULAR	±5°
				L ≤ 4	±0.2
				4 < L ≤ 16	±0.3
				16 < L ≤ 63	±0.4
				L > 63	±0.5
	DATE	REVISED	APPROVED	UNSPECIFIED TOLERANCES	



DSND		SCALE: N/A	MODEL TYPE:
DWN		VIEW:	KEY SWITCH
CHKD		UNIT: mm/in	PART NO.:
APPD		SIZE: A4	XB8585-X-150
			DWG NO.:
			WEIGHT
			SHEET
			REVISI
			1/1
			A0