

PCB LAYOUT PLAN

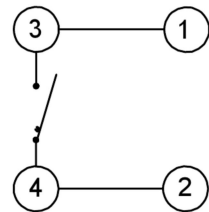

CIRCUIT DIAGRAM

Rated range: 50mA DC12V
 Insulation resistance: ≥100MΩmin (DC100V)
 Compressive strength: AC100V(50/60Hz foy 1 minute)
 Mechanical life: 50000 cycles
 Operating temperature: -10℃~+60℃
 Operation strength: 50±30gf

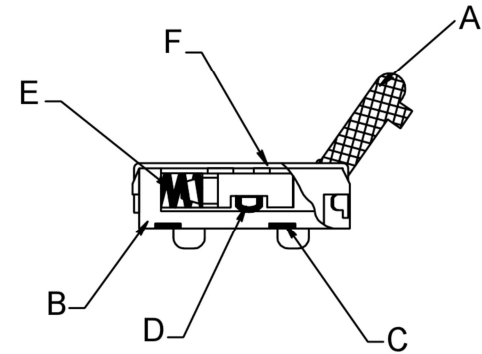

ITEM	PAPT NAMF	QTY	Material	Colour
F	lid	1	SUS	silvery white
E	Shrapnel	1	SUS	silvery white
D	Contact plate	1	PPA	black
C	Solder patch	1	Phosphor bronze	silvery white
B	base	1	PPA	black
A	Button	1	PA66	wihite

				ANGLAR	±5°
				L ≤ 4	±0.2
				4 < L ≤ 16	±0.3
				16 < L ≤ 63	±0.4
				L > 63	±0.5
	DATE	REVISED	APPROVED	UNSPECIFIED TOLERANCES	



DSND		SCALE: N/A	MODEL TYPE: TACT SWITCH		
DWN		VIEW:	PART NO.: TM-1201-X		
CHKD		UNIT: mm/in	DWG NO.:		
APPD		SIZE: A4	WEIGHT	SHEET	REVISIC
				1/1	A0