

REV	DESCRIPTION	DESIGNER	DATE
-----	-------------	----------	------

自由公差		
区分	类别	公差
0	<0.5	±0.10
0.50	<5	±0.15
5.0	<10	±0.20
10.0	<20	±0.30
20.0	<50	±0.40
未标注R角		R0.2
未标注角度公差		±1°

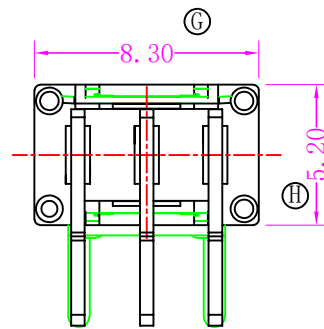
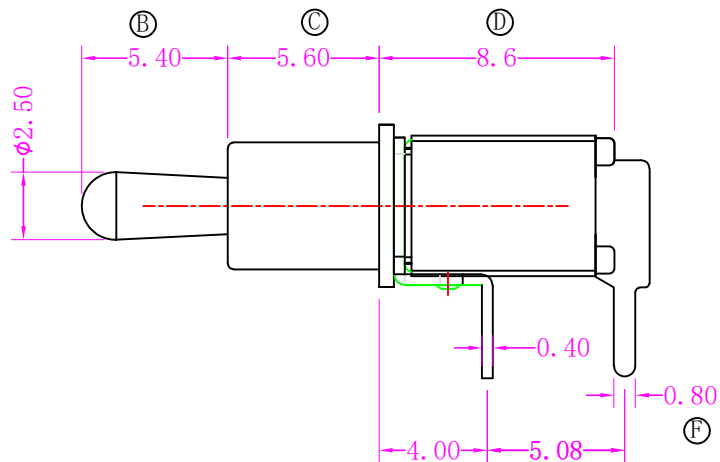
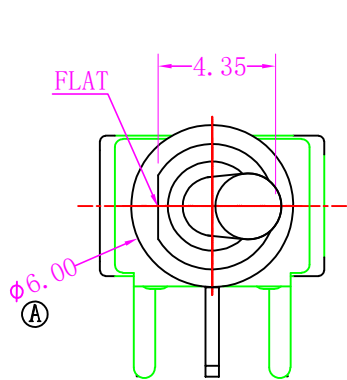
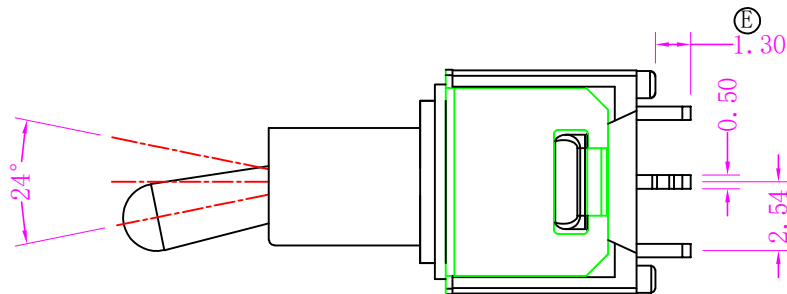

手柄位置及导通端子示意图

Model NO.	POS. 1	POS. 2	POS. 3
102	ON	NONE	ON
SCHEMATIC		NONE	

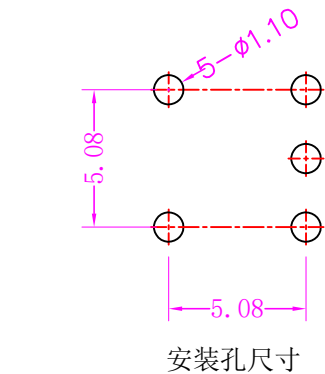

标注: ①-⑧ 尺寸的重点检验尺寸

SCALE	1:1		UNIT: mm
CKD		DWN	黄泳何
APVD		DATE	2019-5-31

NO	NAME	MATERIAL	QTY	FINISHING	NO	NAME	MATERIAL	QTY	FINISHING
1	手柄	黄铜	1	镀铬	7	动触片	H65	1	镀银
2	轴套	黄铜	1	镀铬	8	端子	H65	3	镀银
3	铁盖	SUS	1	本色	9	基座	PPA	1	红色
4	弹簧	碳钢	1	黑色					
5	摆杆	SPCC	1	镀镍					
6	滑块	PA46	1	黑色					

SPECIFICATION NO.	
TITLE	Sub-Miniature Toggle Switch
PART NO.	XB-ST-0-102-C03-N003-RS
MATERIAL NO.	SM00064ZNR