

REV NO/版次	REVISION NOTE/修订注释	DATE/日期	SIGNATURE/签名

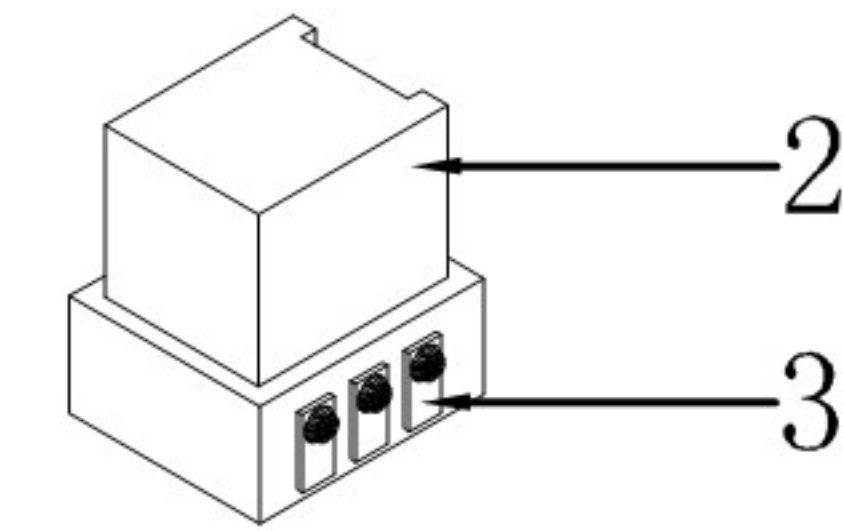
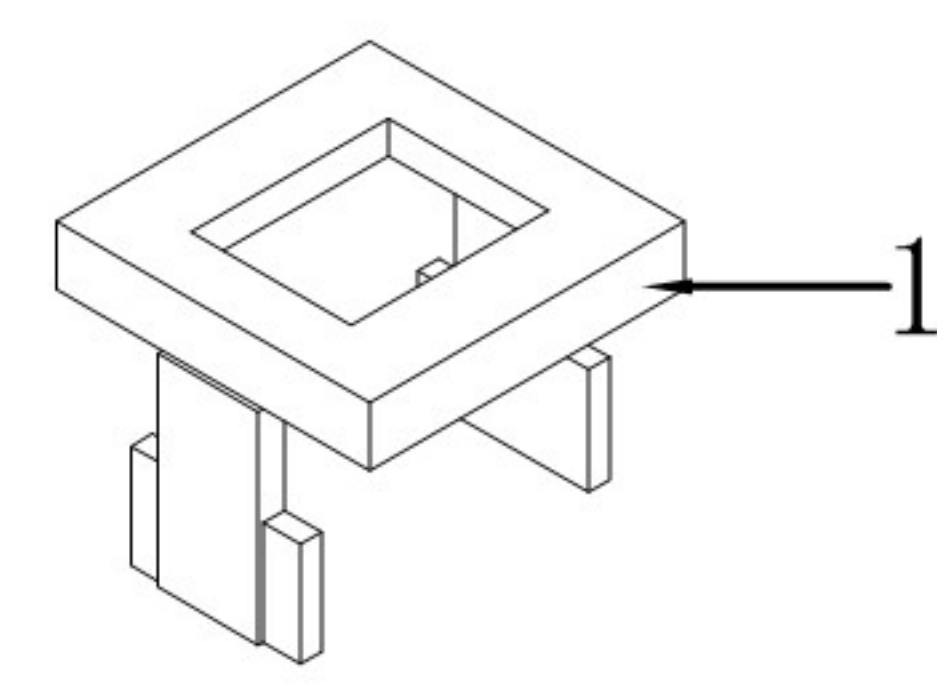
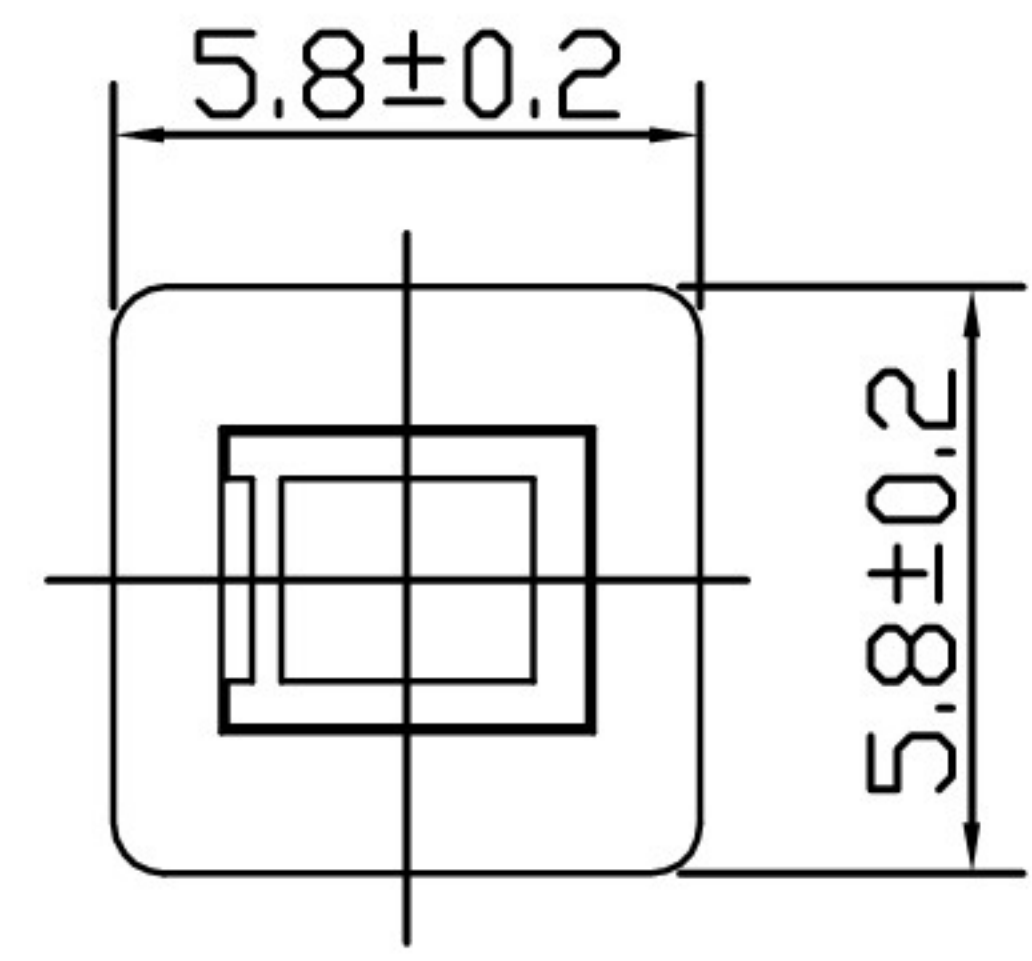

### ELECTRICAL CHARACTERISTICS

1. RATING: DC 30V 0.1A
2. CONTACT RESISTANCE: 100mΩ MAX
3. INSULATION RESISTANCE: 100MΩ MIN
4. DIELECTRIC STRENGTH: AC 250V (50~60Hz) /60S

### MECHANICAL CHARACTERISTICS

1. PRACTICAL TEMPERATURE RANG: -40℃~+85℃
2. OPERATING FORCE: 250±50gf
3. MECHANICAL LIFE: 30,000 cycles

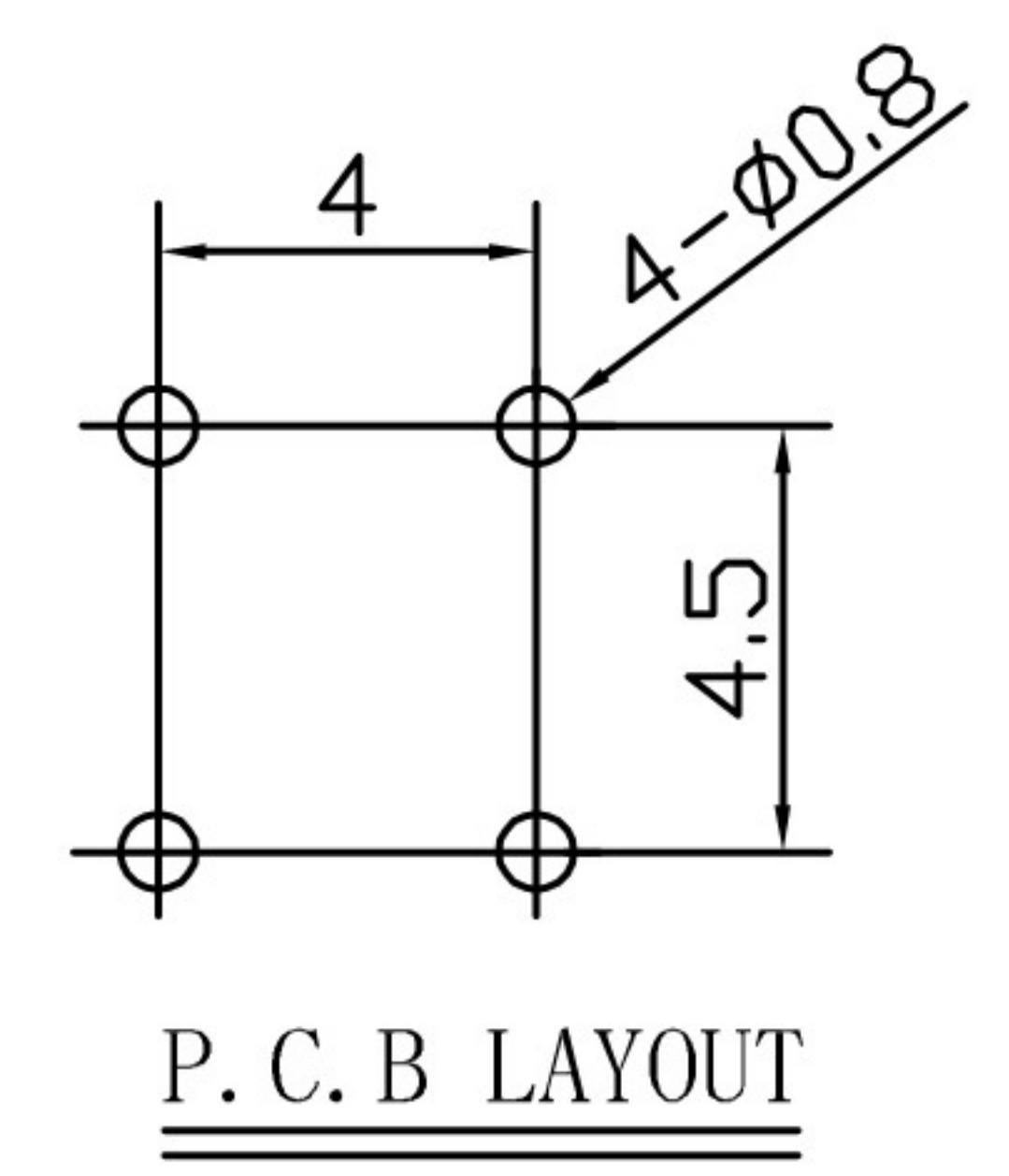
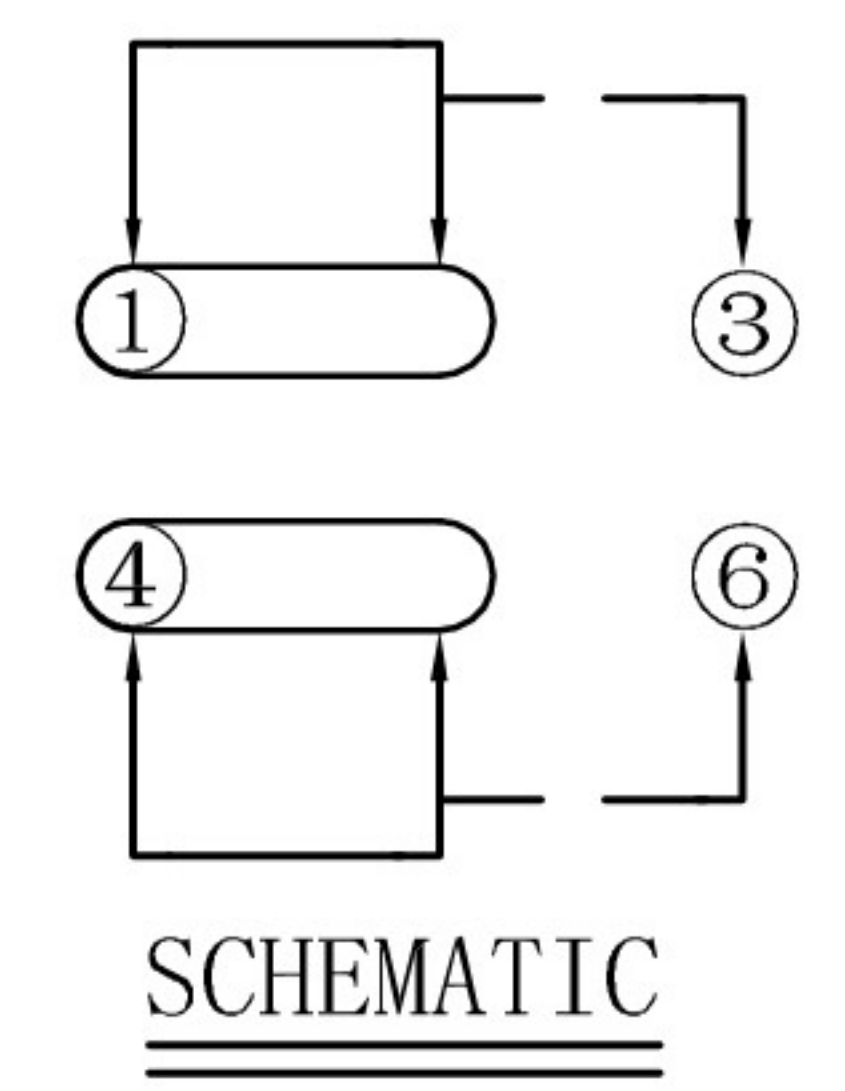
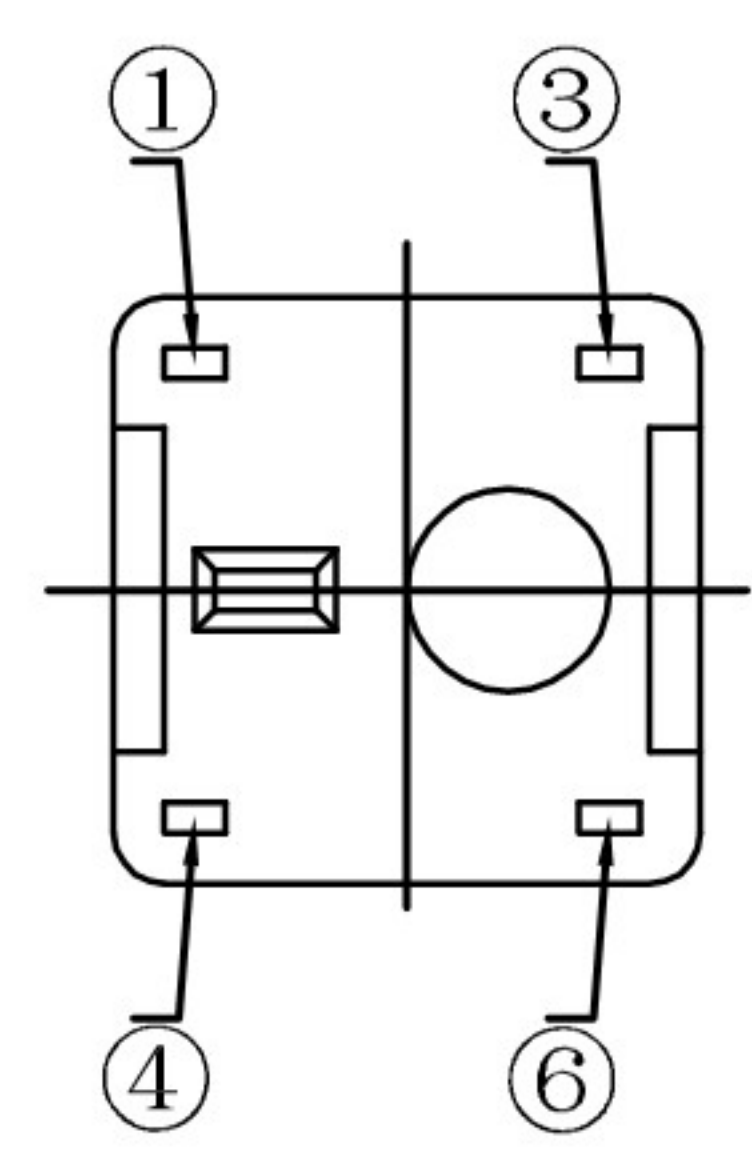
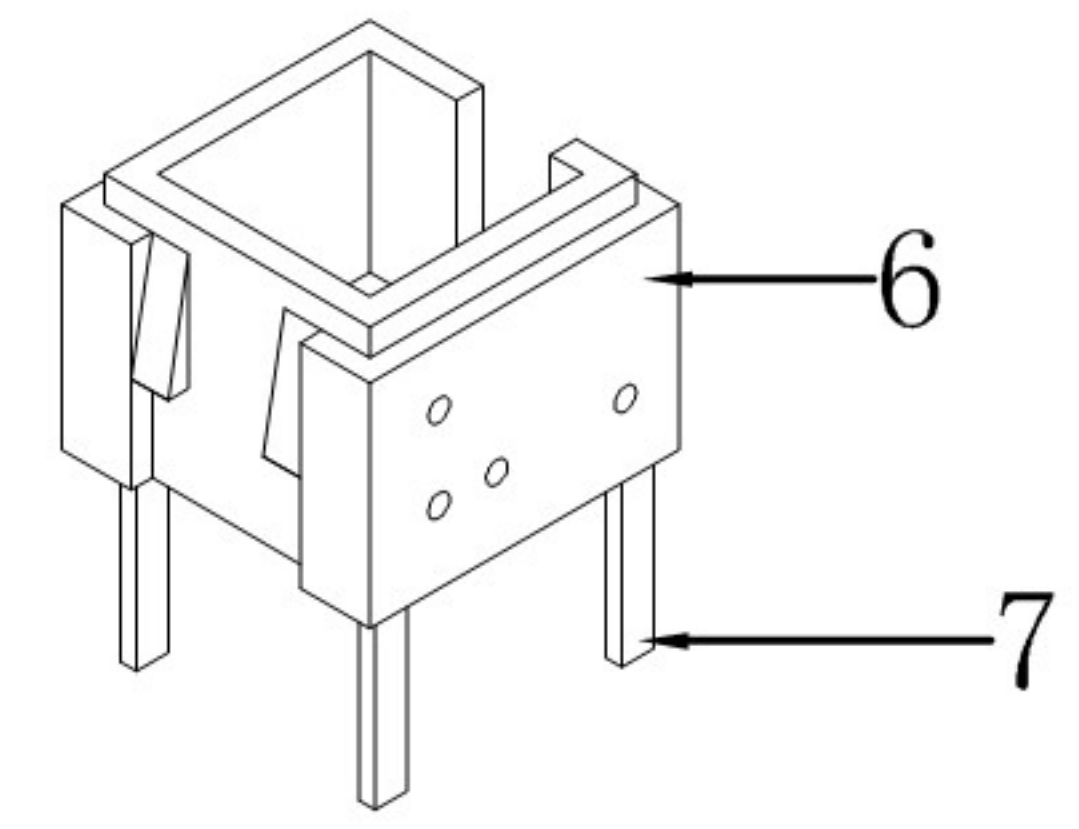
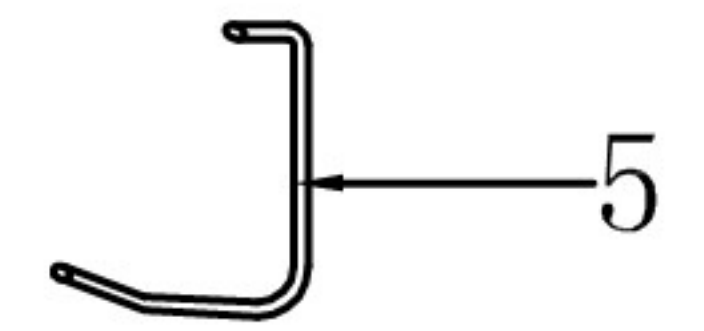
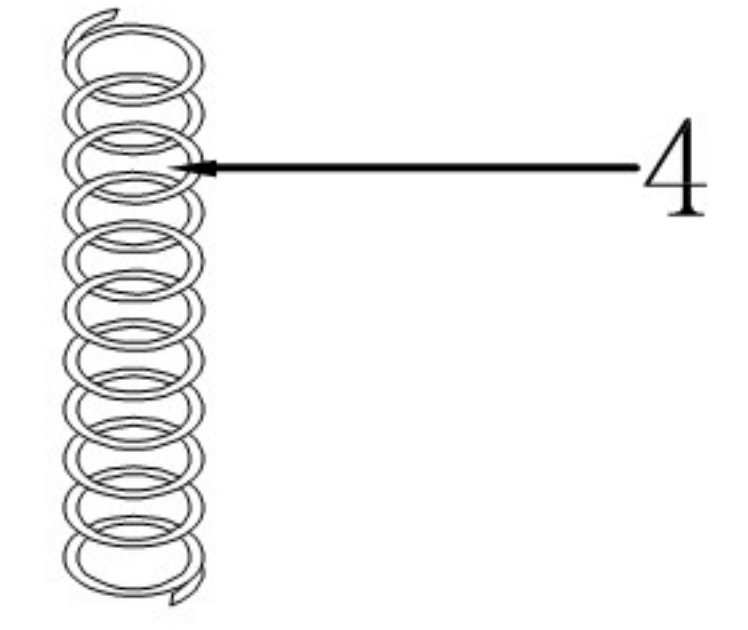
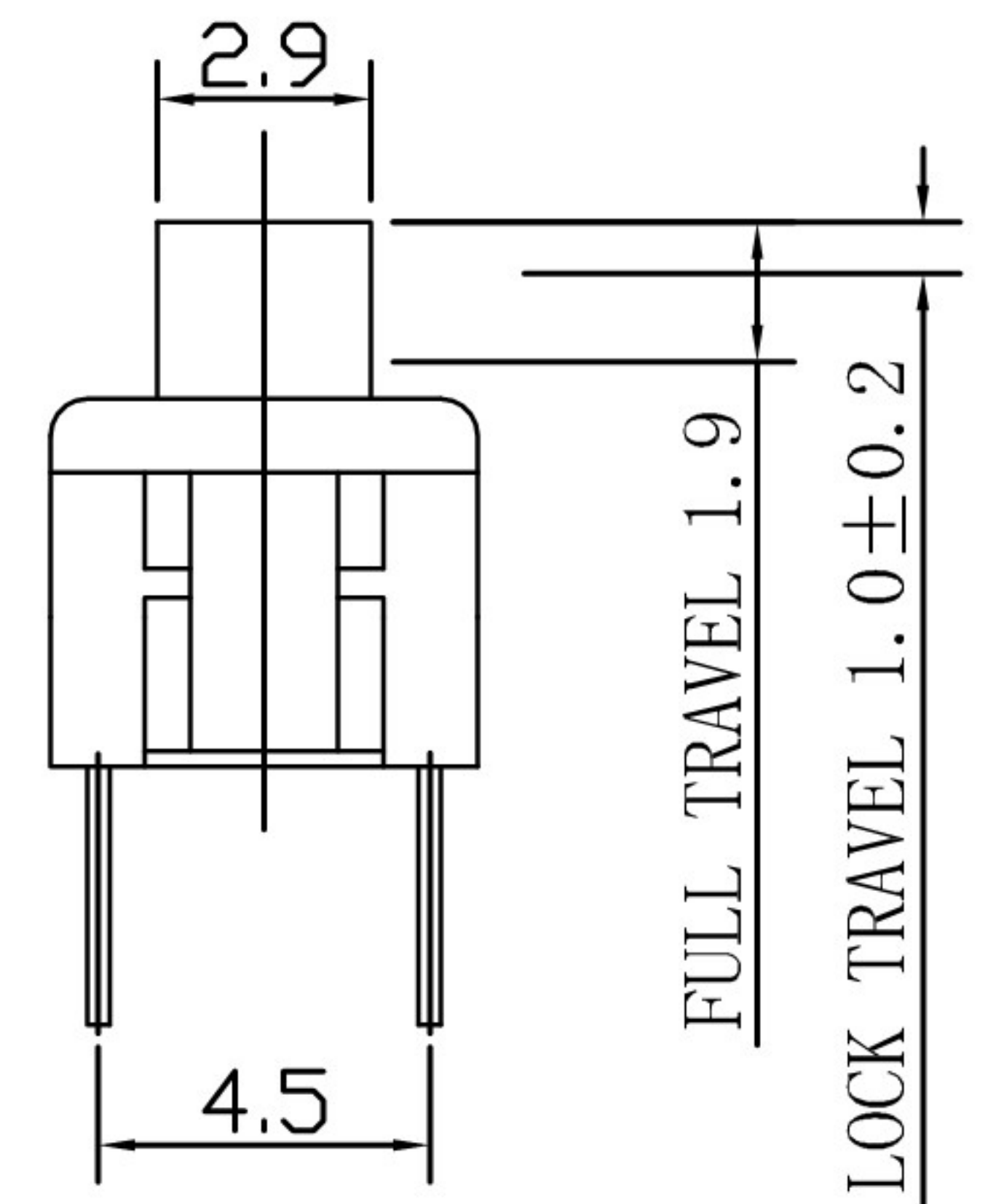
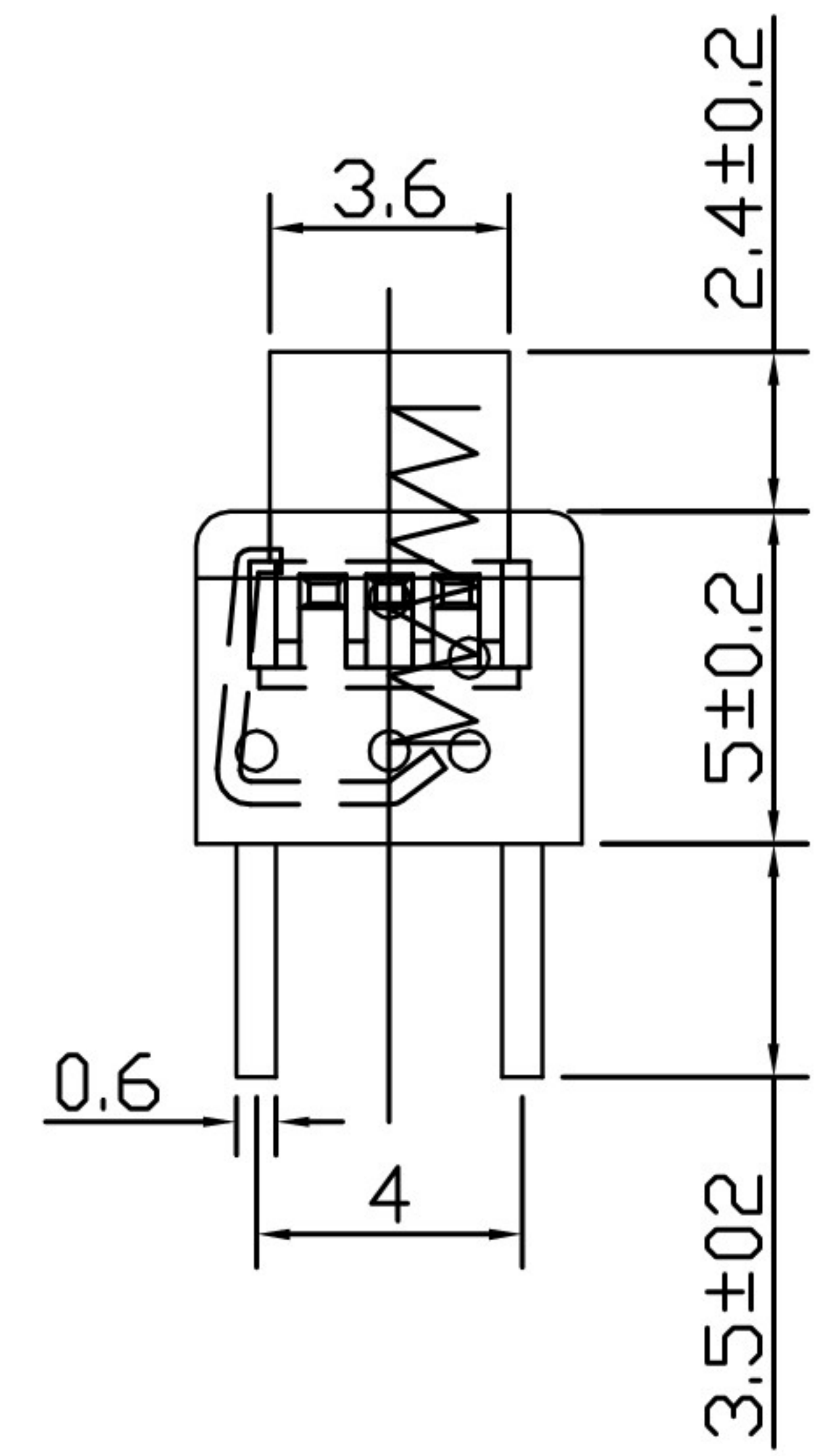

8				
7	TERMINAL	BRASS STRIP	4	Ag PLATED
6	CASE	PPA	1	GRAY
5	LOCK PIN	SUS WIRE	1	NATURAL
4	SPRING	SUS WIRE	1	NATURAL
3	CONTACT	BRONZE	2	Ag PLATED
2	KNOB	PPA	1	WHITE
1	COVER	PPA	1	BLACK
NO.	PART NAME	MATERIAL	QTY.	FINISHING

**XB 东莞市溪榜电子有限公司**  
 Dong Guan Xi Bang Electronics Co., Ltd.

GENERAL TOLERANCE 未指的公差		TITLE 名称 Puhs Switch		
X. ± 0.5	X. ° ± 5°	PART NO. 零件编号 XB-5858D-4P		DWG NO. 图纸编号 ZS-PT-22E58-4P-D
.X ± 0.3	.X ° ± 2°	DRAWN 设计 ROBIN		UNIT 单位 (mm)
.XX ± 0.2	.XX ° ± 1°	SCALE 比例 1:1		PROJ.
.XXX ± 0.1	.XXX ° ± 0.5°	APPROVAL 审批		REV.