

SYMB	REVISION	DATE	APVD.

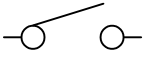
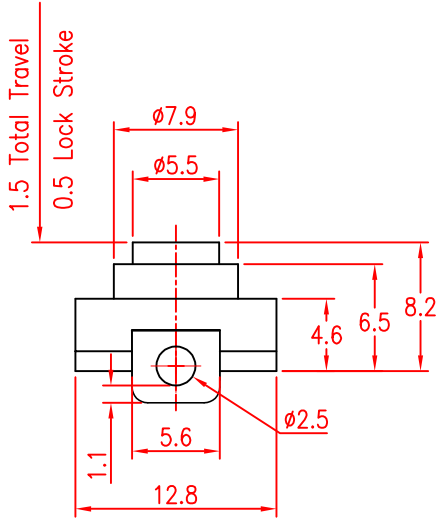
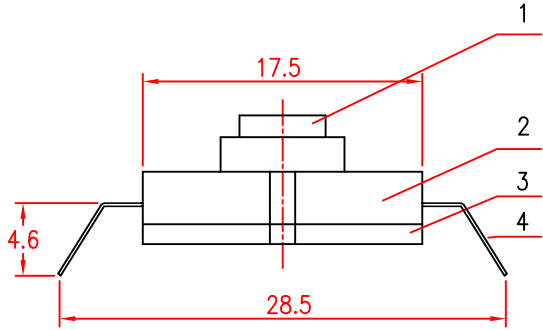
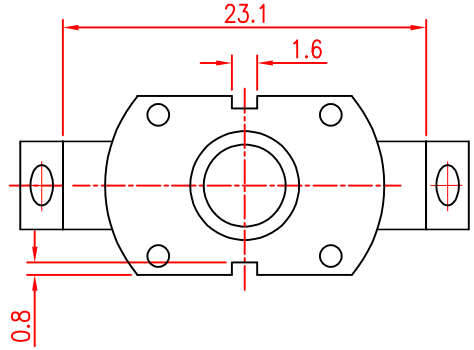

CIRCUIT

13052011Z

TITLE	TORCH SWITCH	DRAWN	L.Liu	TOLERANCE OTHERWISE UNLESS SPECIFIED	8					
PART NO.	XB-TPS-11D52	CHECKED	G.C.Chen	UP TO 5	±0.2	6				
DRAW NO.	P270	APPROVED	H.K.Lai	ABOVE 5 ~ 30	±0.3	5				
SCALE	2:1	UNIT	mm	DATE	21-06-2012	4	TERMINAL	BRASS STRIP	2	Ni PLATED
						3	HOUSING	POM	1	WHITE
						2	COVER	POM	1	WHITE
						1	KNOB	POM	1	WHITE
						NO.	PARTS	MATERIAL	QTY.	FINISHING

**XG** 东莞市溪榜电子有限公司  
DONG GUAN XI BANG ELECTRONICS CO., LTD.

