

RoHS
Compliant

SYMBOL	REVISION	APPROVAL	DATE

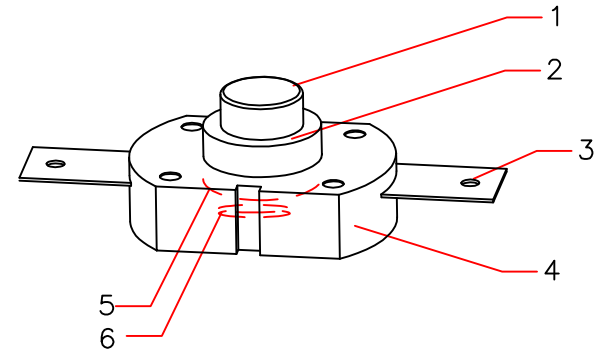
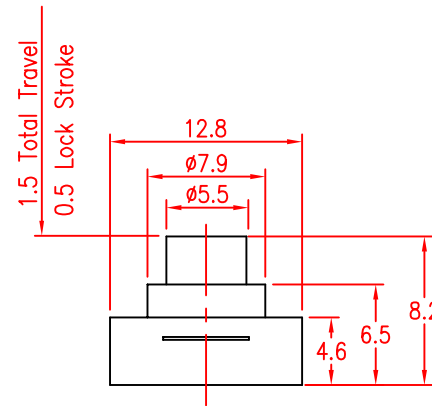
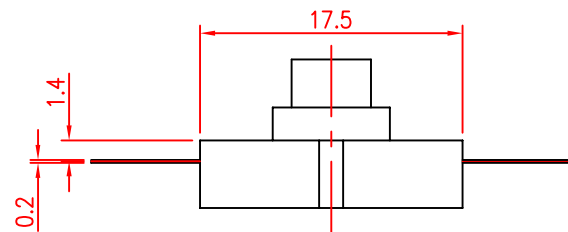
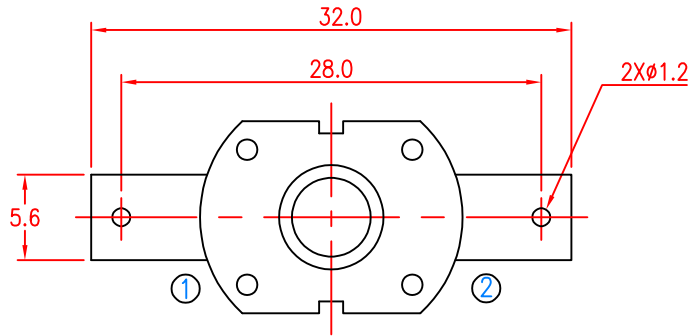

SPECIFICATIONS

- 1.RATING:1A 30V DC
- 2.CONTACT RESISTANCE:100mΩ Max
- 3.INSULATION RESISTANCE:100MΩ Min
- 4.WINDSAND VOLTAGE:500 AC FOR 1 MINUTE
- 5.OPERATING FORCE:550gf;750gf;850gf
- 6.LIFE:50000 CYCLES.



CIRCUIT

No.	DESCRIPTION	MATERIAL	QTY.	FINISHING
1	KNOB	POM	2	WHITE
2	COVER	POM	1	WHITE
3	TERMINAL①②	C2680	2	Ag PLATED OVER Ni PLATED
4	BUTTON	POM	1	WHITE
5	CONTACT PLATE	C2680	1	Ag PLATED OVER Ni PLATED
6	TERMINAL	C2680	1	Ag PLATED OVER Ni PLATED

XB 东莞市溪榜电子有限公司
DONG GUAN XI BANG ELECTRONICS CO., LTD.

COPYRIGHT RESERVED, PLEASE DO NOT COPY.

PART NAME		TORCH SWITCH		DRAWING	L.Liu	DWG.No.	P77
PART NO.		XB-TPS-11D15-N-850		CHECK	G.C.Chen	REV.	B
UNIT: mm	TOLERANCE UNLESS	UP TO 5	±0.2	ANGLE	APPROVAL	DATE	31-03-2012
	OTHERWISE SPECIFIED:	ABOVE 5~30	±0.3				
		ABOVE 30	±0.5	0°±3'			

F

E

D

C

B

A