

REVISION A

SYMB	REVISION	DATE	APVD.

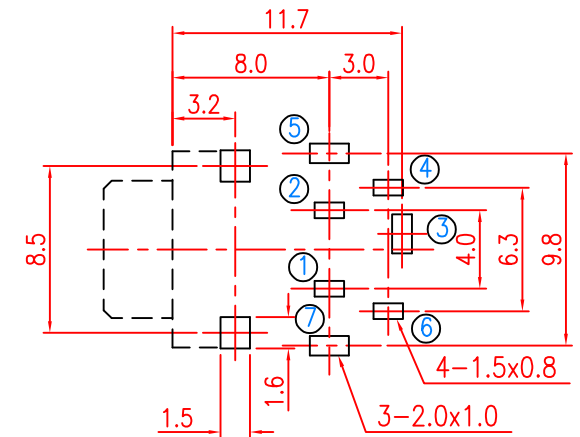

P.C.B LAYOUT  
TOP VIEW

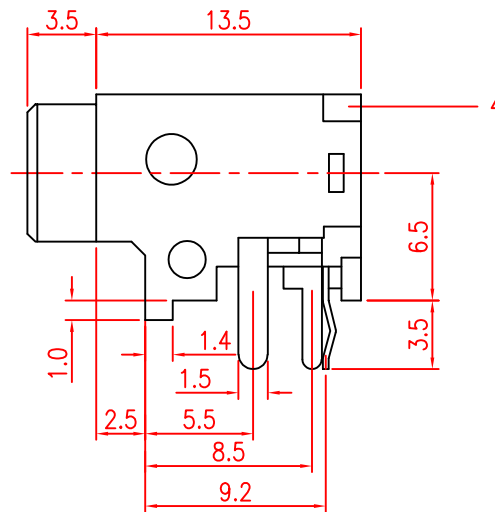
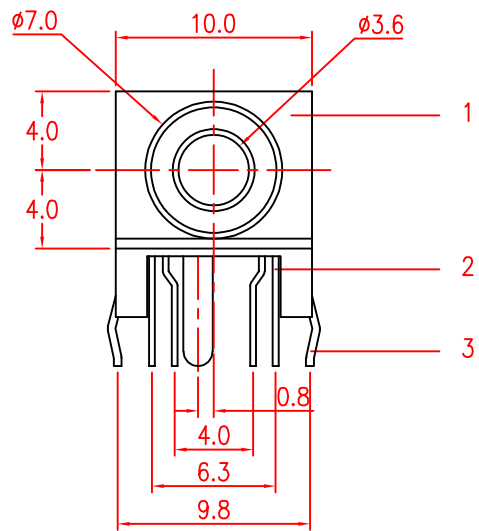
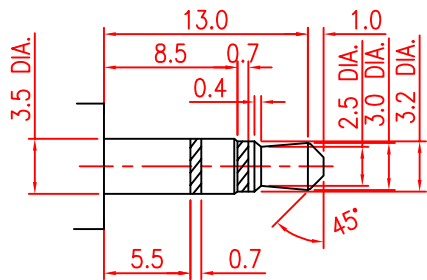

MATE PLUG

CIRCUIT	ST-3517-1	ST-3517-2	ST-3517-3	ST-3517-4
PART NO.	ST-3517-1	ST-3517-2	ST-3517-3	ST-3517-4

TITLE	PHONE JACK(STEREO)	DRAWN	TOLERANCE OTHERWISE UNLESS SPECIFIED		9				
PART NO.	XB-ST-3517-1	CHECKED	UP TO 5	±0.2	8				
DRAW NO.	ST146	APPROVED	ABOVE 5 ~ 30	±0.3	7				
SCALE	5:2	UNIT	mm	DATE	25-02-2005	6			
						5			
						4	COVER	POM	1 BLACK
						3	TERMINAL 1.2.3.5.7	PHOSPHOR BRONZE	5 Ag PLATED
						2	TERMINAL 4.6	BRASS STRIP	2 Ag PLATED
						1	HOUSING	PBT	1 BLACK
						NO.	PARTS	MATERIAL	QTY. FINISHING

