

SYMB	REVISION	DATE	APVD.
	PS SERIES → PS SERIES	13-05-2011	陳工

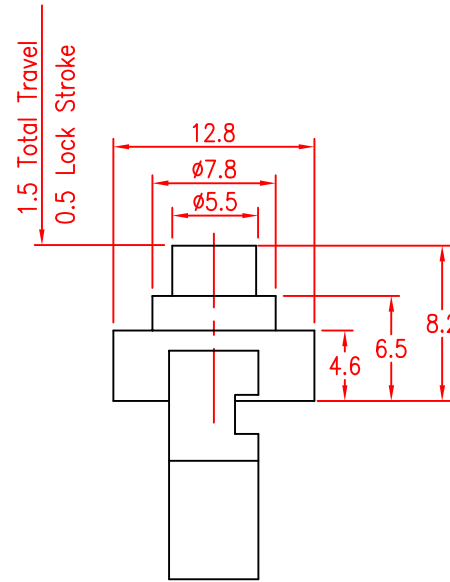
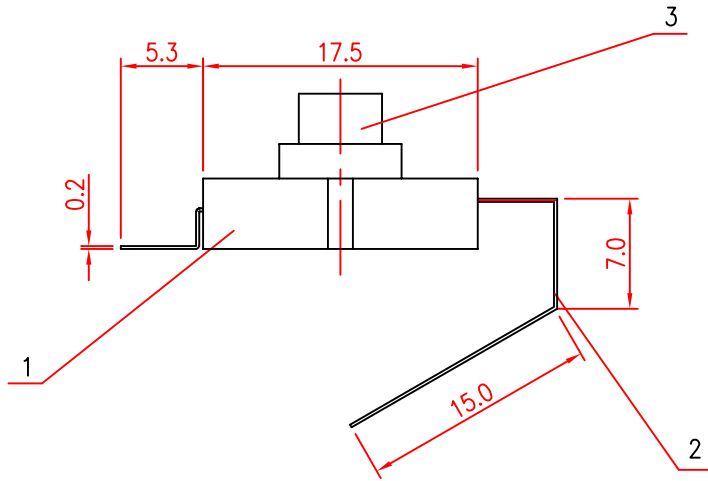
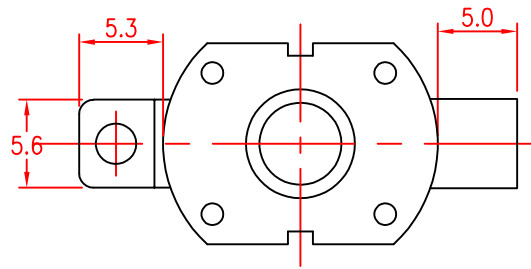

CIRCUIT

13052011Z

TITLE	TORCH SWITCH		DRAWN	TOLERANCE OTHERWISE UNLESS SPECIFIED		8			
PART NO.	XB-PS-11D47		CHECKED	UP TO 5	±0.2	7			
DRAW NO.	P232		APPROVED	ABOVE 5 ~ 30	±0.3	6			
SCALE	2:1	UNIT	mm	DATE	23-9-2008	5			
						4			
						3	KNOB	POM	1 WHITE
						2	TERMINAL	C2680R-EH	2 Ag PLATED
						1	HOUSING	POM	1 WHITE
						NO.	PARTS	MATERIAL	QTY. FINISHING

**XB** 东莞市溪榜电子有限公司  
DONG GUAN XI BANG ELECTRONI CS CO., LTD.

