

REVISION A RoHS Compliant

SYMB	REVISION	DATE	APVD.

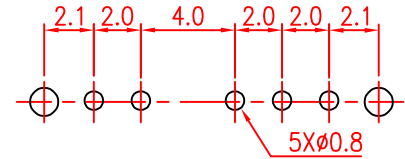

P.C.B LAYOUT  
TOP VIEW

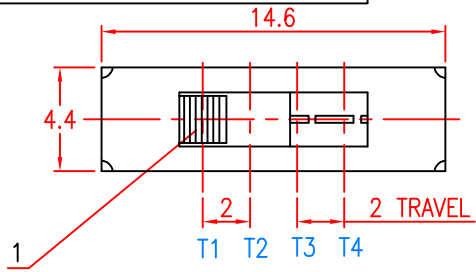
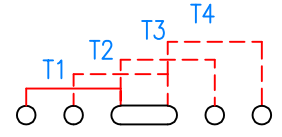
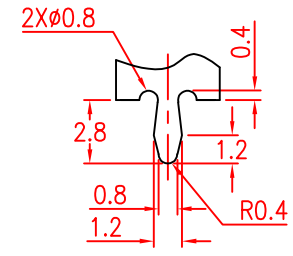
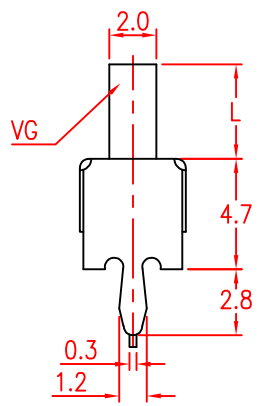
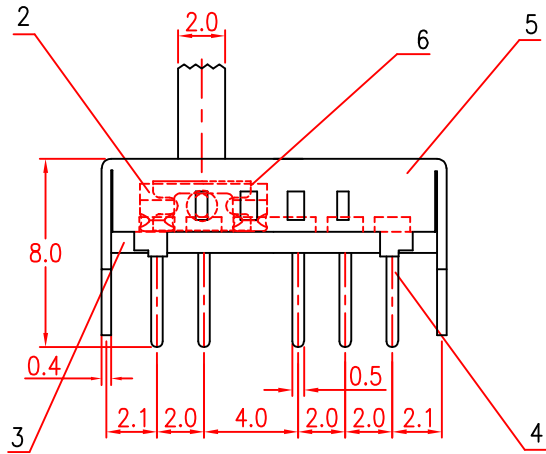

CIRCUIT

L=4.0mm

TITLE	SLIDE SWITCH	DRAWN	L.Liu	TOLERANCE OTHERWISE UNLESS SPECIFIED	8					
PART NO.	XB-SS-14D02-G4-S	CHECKED	G.C.Chen	UP TO 5	±0.2	6	SPRING	C5191	1	NATURAL
DRAW NO.	S389	APPROVED	H.K.Lai	ABOVE 5 ~ 30	±0.3	5	FRAME	SPCC	1	Ni PLATED
SCALE	3:1	UNIT	mm	DATE	30-12-2004	4	TERMINAL	BRASS STRIP	5	Ag PLATED
						3	BASE	PHENOLIC RESIN	1	NATURAL
						2	CONTACT PLATE	PBS	1	Ag PLATED
						1	KNOB	POM	1	BLACK
						NO.	PARTS	MATERIAL	QTY.	FINISHING

**XG** 东莞市溪榜电子有限公司  
DONG GUAN XI BANG ELECTRONICS CO., LTD.

