

SPECIFICATION:

1. Electrical characteristics

- 1-1. Current rating: DC 1A max.
- 1-2. Voltage rating: DC 12V.
- 1-3. Contact resistance: 50mΩ max.
After test: 100mΩ max.
- 1-4. Insulation resistance: 100MΩ Min. at 500V DC.
- 1-5. Withstanding voltage: 500V AC for 1 minute.

2. Mechanical characteristics

- 2-1. Life test: 5000 cycles min,
- 2-2. Mating force: 4-30N,
Unmating force: 4-30N.

**RECOMMENDED P.C.B LAYOUT
TOP VIEW (TOLRANCE: ±0.05)**

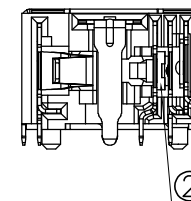
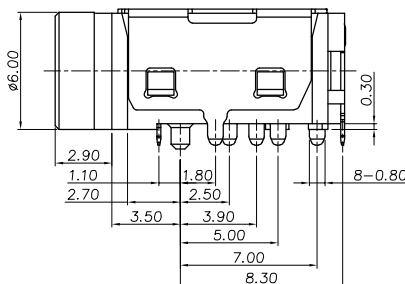
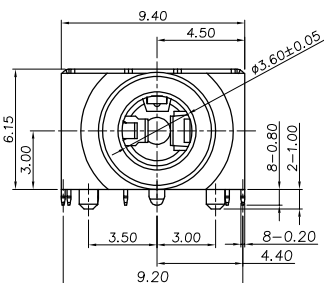
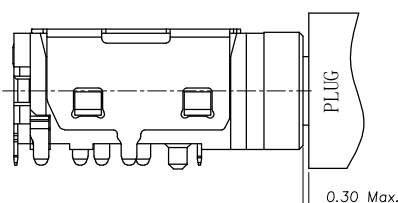

MODEL NO. :

XB-PJ-D3155A- A BK7 AMO3 L- RH
(1) (2) (3) (4) (5) (6)

- (1) Series no.
- (2) Schematic type: A
- (3) Housing color:
BK7=Black
- (4) Terminal plating:
AMO3=Plating Tin/Au
- (5) Packing mode: L=Reel packing
- (6) Environmental requirements:
RH=RoHS 2.0 + Halogen free

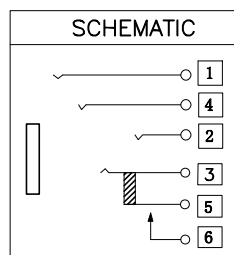
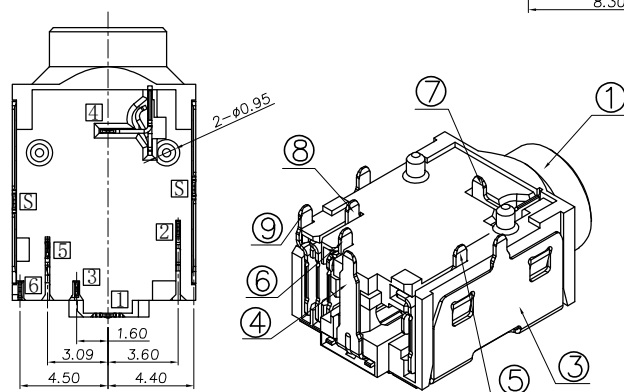
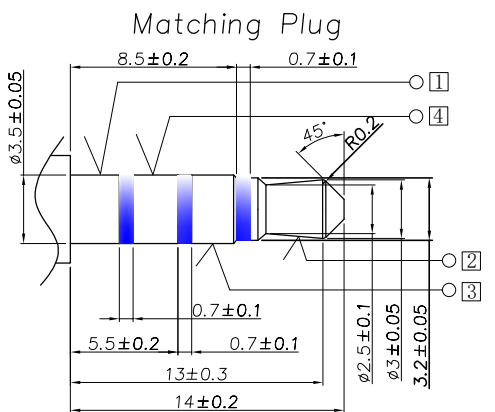

NO.	DESCRIPTION	QTY	MATERIAL	REMARK
⑨	Make Spring	⑥ 1	Phosphor bronze, 0.20t	5μ"Gold On Contact Area, Matte Tin Plating on Solder Tail Area, All over Nickel Plated
⑧	Transfer Spring	⑤ 1	Phosphor bronze, 0.20t	
⑦	Ring spring	④ 1	Phosphor bronze, 0.20t	
⑥	Ring spring	③ 1	Phosphor bronze, 0.20t	
⑤	Tip spring	② 1	Phosphor bronze, 0.20t	
④	Earth spring	① 1	Phosphor bronze, 0.20t	Black
③	Shell	①	Brass, 0.20t	
②	Insulator	1	High temperature plastic	Black
①	Housing	1	High temperature plastic	

ECN NO.	REV	DATE	DESCRIPTION	CHANGE	APPRO.	GENERAL TOLERANCE UNLESS OTHERWISE NOTED	SCALE: 3:1	UNIT:mm	A4	SHEET:1 of 1
						Angle ±2° 10<L≤20 ±0.3 5<L≤10 ±0.25 L≤5 ±0.20	DESIGN 刘伟 2015.05.27			
							CHECK			
	A-0	2015.5.27	NEW	刘伟	余军		APPROVAL			

东莞市溪榜电子有限公司 DONG GUAN XI BANG ELECTRONI CS CO., LTD.	
TITLE:	φ3.5mm PHONE JACK
MODEL NO.	XB-PJ-D3155A-ABK7AMO3L-RH
FILE NO.	Q/SSY.QW-001A-0533