

CAD FILE:

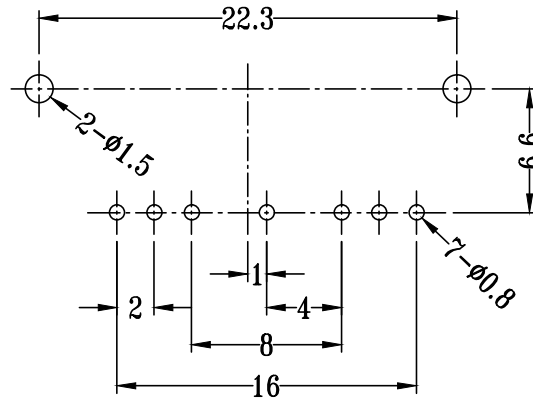

P.C.B LAYOUT  
BOTTOM VIEW

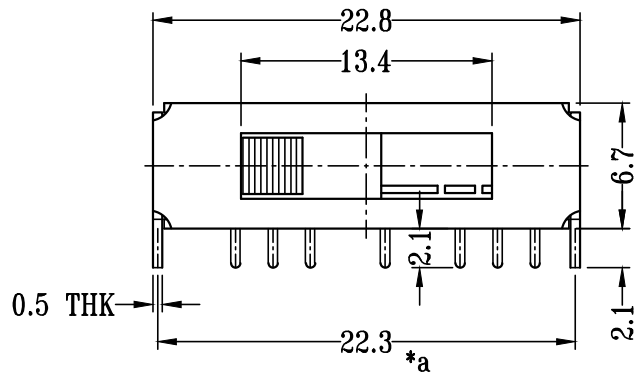
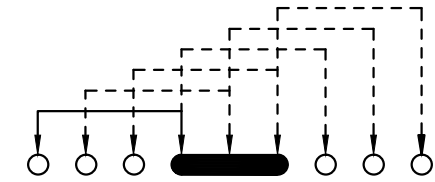

SCHEMATIC (SHORTING)

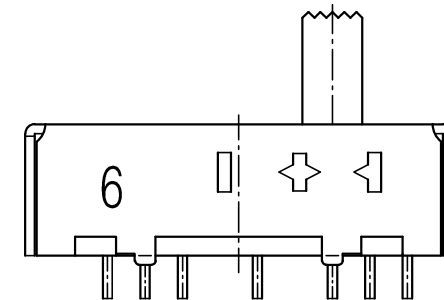
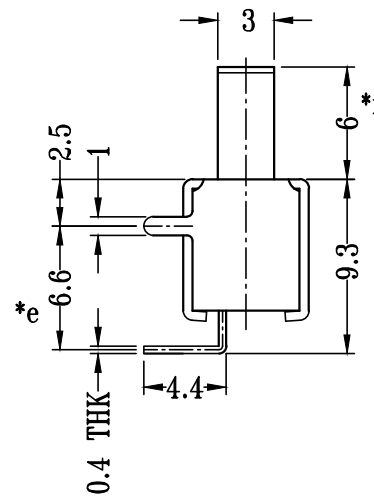
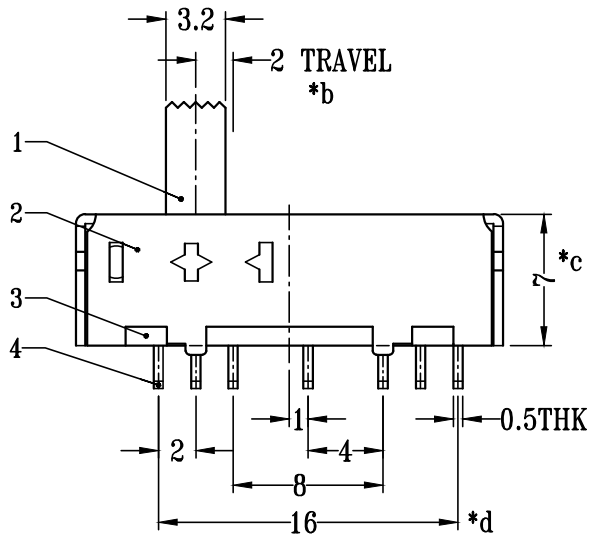

注：“\*”表示关键尺寸（6个）。

NO.	PARTS	MATERIALS	Q'TY	FINISH	TOLERANCE UNLESS SPECIFIED	ISSUE	DATE	DESCRIPTIONS OF REVISION	APPD.
8									
7	STEEL BALL	STEEL	2	Ni PLATED					
6	SPRING	STEEL WIRE	1	NATURAL	WITHIN 1.5mm : ±0.1mm	A1	2019-09-18	铁壳增加字唛“6”	曾鹏
5	CONACT CLIP	PBS STRIP	1	Ag CLAD	OVER 1.5mm : ±0.2mm	ISSUE	DATE	DESCRIPTIONS OF REVISION	APPD.
4	TERMINAL	BRASS STRIP	7	Ag PLATED	TITLE : VERTICAL SLIDE SWITCH		UNIT : mm	DRWG NO.: XB-SS-16F03	
3	BASE	PHENOLIC RESIN	1	NATURAL	MODEL: XB-SS-16F03 (1P6T)		SCALE: 5:2	DWN.	曾小伟 2019-09-18
2	FRAME	STEEL STRIP	1	Ni PLATED	东莞市溪榜电子有限公司 DONG GUAN XI BANG ELECTRONICS CO., LTD.		CHK'D	吴开庆	2019-09-18
1	KNOB	PA66	1	BLACK			APPD.	曾鹏	2019-09-18