

SYMB	REVISION	DATE	APVD.

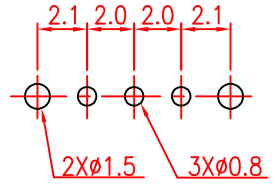

P.C.B LAYOUT
TOP VIEW

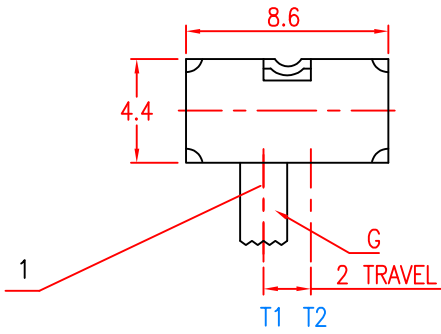
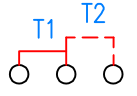
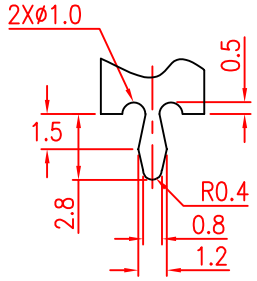
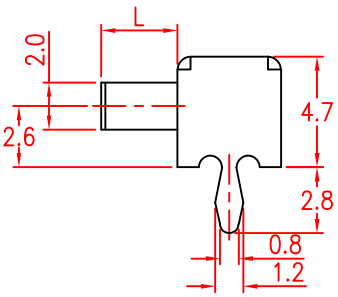
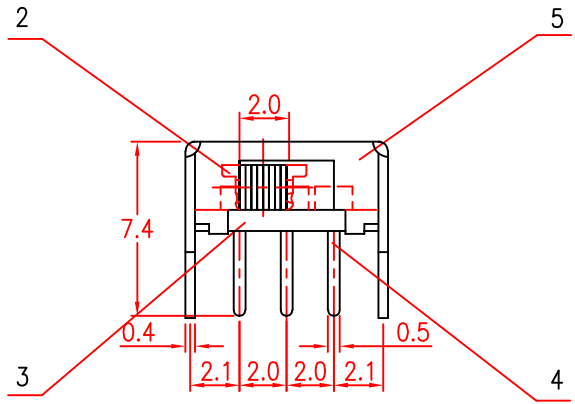

CIRCUIT

L=4.0mm

TITLE	SLIDE SWITCH	DRAWN	L.Liu	TOLERANCE OTHERWISE UNLESS SPECIFIED	8				
PART NO.	XB-SK-12D03	CHECKED	G.C.Chen	UP TO 5	±0.2	6			
DRAW NO.	K66	APPROVED	H.K.Lai	ABOVE 5 ~ 30	±0.3	5	FRAME	SPCC	1 Ni PLATED
				ABOVE 30 ~ 50	±0.4	4	TERMINAL	BRASS STRIP	3 Ag PLATED
				ABOVE 50	±0.5	3	BASE	PHENOLIC RESIN	1 NATURAL
SCALE: 3:1	UNIT: mm	DATE: 30-11-2004		ANGLE	±3'	2	CONTACT PLATE	PBS	1 Ag PLATED

XB 东莞市溪榜电子有限公司
DONG GUAN XI BANG ELECTRONI CS CO., LTD.

NO.	PARTS	MATERIAL	QTY.	FINISHING
1	KNOB	POM	1	BLACK
2	CONTACT PLATE	PBS	1	Ag PLATED
3	BASE	PHENOLIC RESIN	1	NATURAL
4	TERMINAL	BRASS STRIP	3	Ag PLATED
5	FRAME	SPCC	1	Ni PLATED