

REV.	ECN NO.	DESCRIPTION	DATE	DESIGN
A0		新版发行	2020.11.01	高鹏

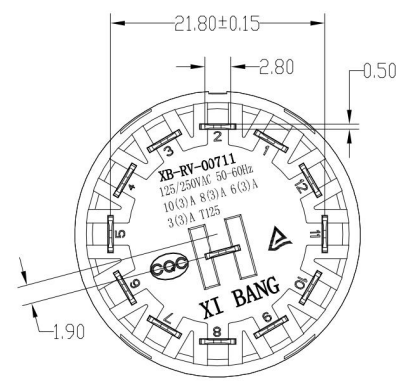

- 1、ELECTRICAL RATING:3(3)A 250VAC T125.
- 2、ROTATION ANGLE:30° .
- 3、CONTACT RESISTANCE:≤50mΩ (INITIAL VALUE).
- 4、INSUIATION RESISTANCE:≥100MΩ (EXPERIMENTAL VOLATAGE 500VDC).
- 5、RATED IMPULSE WITHSTAND VOLTAGE 1500VAC, 5mA.
- 6、ELECTRICAL SERVICE LIFE:10000(CYCLES).
- 7、TORSION FORCE:0.6Kg±0.3KGF.
- 8、CIRCUIT DIAGEAM

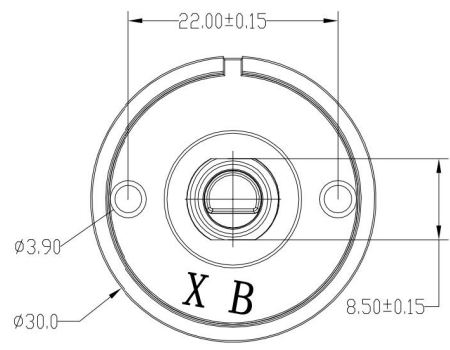
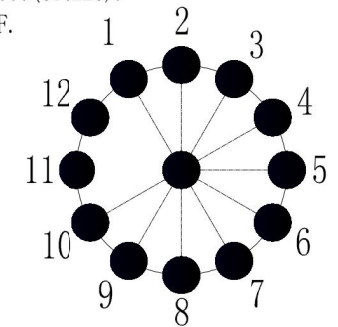

电路功能

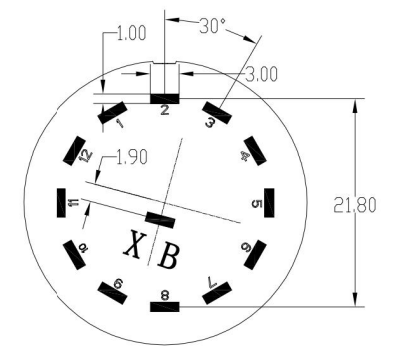
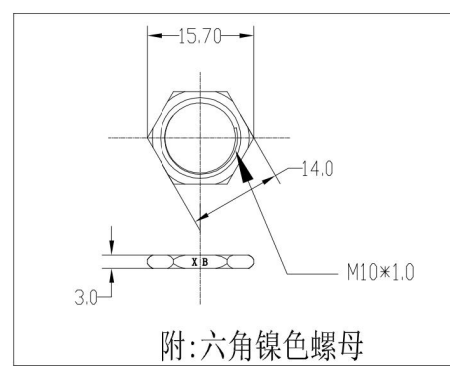
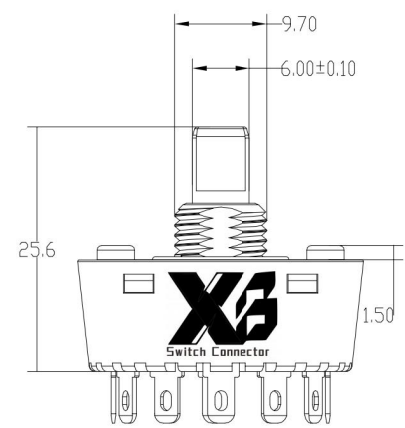
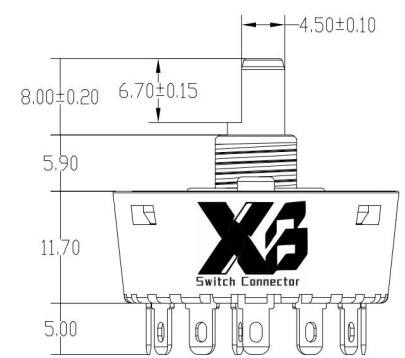

PCB LAYOUT

PRELIMINARY

UNLESS OTHERWISE SPECIFIED TOLERANCES		<b>东莞市溪榜电子有限公司</b> DONG GUAN XI BANG ELECTRONICS CO., LTD.			
DECIMALS	ANGLES	TITLE	旋转开关		
X ±0.50	X ±2°	DATE	20.11.01	PART NO: XB-RV-00711	
X.X ±0.38	X.X ±1°	DWN	高鹏	SCALE:1/1	UNIT: mm
X.XX ±0.15	X.XX ±0.5°	CHKD	邢霓展	SIZE: A4	SHEET:1 OF 1
X.XXX ±0.05		APVD	贺龙飞	DWG NO.	VIEW:

