 XB Connectivity	Doc. No.	SP-A0162-01	Page No.	1/19
	Date Issued	2015-04-06	Prepared by	Josephine
	Date revised	2018-11-23	checked by	Jay
Product Specification	Rev. No.	01	Approved by	Mei Chen
Title: USB TYPE C 3.1				

1. SCOPE (适用范围)

This specification covers the performance, tests and quality requirements for the USB TYPE C Connector.(XB Connectivity 本规范涵盖了 USB TYPE C 连接器的性能、测试和质量要求。)

2. PRODUCT DESCRIPTION (产品描述)

DESCRIPTION (描述)	Part Number (料号)
3.1TYPE-C连接器 16PIN 四脚全贴,成型款,有弹	U262-16XN-4BSS73-T

3. APPLICABLE DOCUMENT (适用文件)

The following documents form a part of this specification to the extent specified herein. In the event of conflict between the requirements of this specification and the product drawing, the product drawing shall take precedence. In the event of conflict between the requirements of this specification and the referenced documents, this specification shall take precedence.(XB Connectivity 下列文件构成本规范的一部分，在此规定的范围内。本规范要求与产品图纸有冲突时，以产品图纸为准。如果本规范的要求与参考文件发生冲突，应以本规范为准。)

- EIA 364 Test procedures for electrical connector (EIA364电子连接器的测试程序)
- UL 94-V0 Flammability standard (UL 94-V0 阻燃性标准)

4. REQUIREMENTS (要求)

4.1. Design and Structure (设计和结构)

Product shall be of the design, structure and physical dimensions specified on the applicable product drawing.

 XB Connectivity	Doc. No.	SP-A0162-01	Page No.	2/19
	Date Issued	2015-04-06	Prepared by	Josephine
	Date revised	2018-11-23	checked by	Jay
Product Specification	Rev. No.	01	Approved by	Mei Chen
Title: USB TYPE C 3.1				

(XB Connectivity 产品的设计、结构和物理尺寸参考所适用的产品图纸)

4.2. Materials/ Finish (材料/表面处理)

Materials used in the structure of product shall be as specified on the applicable product drawing. (XB Connectivity 产品结构中使用的材料参考所适用的产品图纸)

4.3. Ratings (额定功率)

Operating temperature range 工作温度范围: $-25^{\circ}\text{C} \sim +80^{\circ}\text{C}$

Storage Temperature Range 储存温度范围: $-40^{\circ}\text{C} \sim +85^{\circ}\text{C}$

Rated Voltage 额定电压: 100 Volts AC (RMS)

Rated Current 额定电流: Signal Pins: 0.25A ; VBUS Pins : 3 A ; VCONN Pins : 1.5 A

USB Type-C Receptacle

A1	A2	A3	A4	A5	A6	A7	A8	A9	A10	A11	A12
GND	TX1+	TX1-	VBUS	CC1	D+	D-	SBU1	VBUS	RX2-	RX2+	GND
GND	RX1+	RX1-	VBUS	SBU2	D-	D+	CC2	VBUS	TX2-	TX2+	GND
B12	B11	B10	B9	B8	B7	B6	B5	B4	B3	B2	B1

USB Type-C Plug

A12	A11	A10	A9	A8	A7	A6	A5	A4	A3	A2	A1
GND	RX2+	RX2-	VBUS	SBU1	D-	D+	CC	VBUS	TX1-	TX1+	GND
GND	TX2+	TX2-	VBUS	VCONN			SBU2	VBUS	RX1-	RX1+	GND
B1	B2	B3	B4	B5	B6	B7	B8	B9	B10	B11	B12

5. TEST STANDARD (测试标准)

Unless otherwise specified, the standard range of atmospheric conditions for making measurements and tests are as follows (除另有说明外，用以进行测量和测试的标准环境条件范围如下)

5.1 Ambient temperature (环境温度) : 5°C to 35°C

5.2 Relative humidity (相对湿度) : 45% to 85%

5.3 Air pressure (气压) : 86Kpa to 106Kpa

6. HOWEVER, IF DOUBTS ARISE CONCERNING JUDGMENTS. PERFORM UNDER THE FOLLOWING STANDARD CONDITIONS. (但是，如果对判决产生疑问，按照下列标准条件执行)

 XB Connectivity	Doc. No.	SP-A0162-01	Page No.	3/19
	Date Issued	2015-04-06	Prepared by	Josephine
	Date revised	2018-11-23	checked by	Jay
Product Specification	Rev. No.	01	Approved by	Mei Chen
Title: USB TYPE C 3.1				

Temperature (温度) : $23 \pm 1^{\circ}\text{C}$.

Humidity (湿度) : $50\% \pm 2\% \text{ RH}$.

Air Pressure (气压) : 86~106kPa

 XB Connectivity	Doc. No.	SP-A0162-01	Page No.	4/19
	Date Issued	2015-04-06	Prepared by	Josephine
	Date revised	2018-11-23	checked by	Jay
Product Specification	Rev. No.	01	Approved by	Mei Chen
Title: USB TYPE C 3.1				

7. PERFORMANCE AND TEST DESCRIPTION (性能和测试类型)

7.1 APPRARANANCE (外观)

ITEM	DESCRIPTION (类型)	TEST CONDITION (测试条件)	REQUIREMENT (要求)
1	Appearance (外观)	Visual. (目视)	Should not have any flaw Scratch discoloration and crushed (无任何裂痕、刮伤、 污染和变形)

7.2 ELECTRICAL (电气)

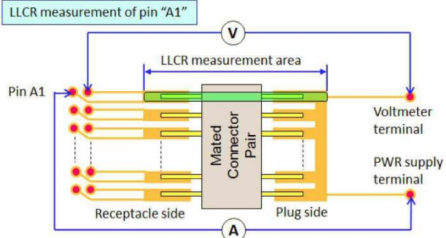
ITEM	DESCRIPTION (类型)	TEST CONDITION (测试条件)	REQUIREMENT (要求)
1	Low Level Contact Resistance (接触电阻)	EIA 364-23B Subject the mated specimen to 20mV maximum open circuit voltage and 100mA maximum current. (将公母对插后, 在回路施加直流最大 20mV 100mA 的电流。) 	40 mΩ (Max) initial for VBUS, GND and all other contacts. Maximum change (delta) of +10 mΩ after environmental stresses. (初始包括信号, 接地所有的触点 40mΩ 最大, 测试后最大 10 mΩ变化量)
2	Dielectric Withstanding Voltage (耐电压)	EIA 364-21 No breakdown shall occur when 100 Volts AC (RMS) is applied between adjacent contacts of unmated and mated connectors. (对插与未对插的连接器, 在相邻端子之间施加 100V AC 1mA 的电流 1 分钟)	No Breakdown (没有损坏)
3	Insulation Resistance (绝缘电阻)	EIA 364-21 After 100 VDC for 1 minute, Measure the insulation resistance between the adjacent contacts of mated and unmated connector assemblies (对插与未对插的连接器, 在相邻端子之间施加 100V DC 1mA 的电流 1 分钟)	100M Ω MIN.



Doc. No.	SP-A0162-01	Page No.	5/19
Date Issued	2015-04-06	Prepared by	Josephine
Date revised	2018-11-23	checked by	Jay
Rev. No.	01	Approved by	Mei Chen

Product Specification

Title: USB TYPE C 3.1

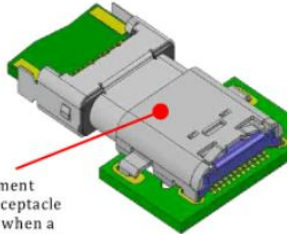
4	<p>Contact Current Rating (额定电流)</p>	<p>EIA 364-70, Method 2</p> <p>(1). A current of 5.0 A shall be applied collectively to VBUS pins (i.e., pins A4, A9, B4, and B9) and 1.25 A applied to the VCONN pin (i.e., B5 of the plug connector) with the return path through the corresponding GND pins (i.e., pins A1, A12, B1, and B12). A minimum current of 0.25 A shall also be applied individually to all the other contacts.</p> <p>(5A 的电流适用于 VBUS 引脚(即引脚 A4, A9, B4, B9) 和 1.25A 适用于 VCONN 引脚(即 B5), 通过相应的 GND 脚(即 A1, A12, B1, B12), 0.25A 最小的电流其它所有的接脚)</p> <p>(2). When current is applied to the contacts, the temperature of the connector pair shall be allowed to stabilize. (当电流作用于触点时, 连接器的温度应保持稳定)</p> <p>(3). The measurement shall be done in still air. (测量应该在静止的空气中进行)</p> <p>(4). The connectors shall be oriented such that the accessible outer shell surface is on top and horizontal to the ground. (以连接器为导向, 使外壳的表面处于顶部, 与地面水平)</p> <p>(5). The plug and receptacle may require modification to access solder tails or cable attachment points. (插头与插座可能需要修改, 以便接入焊脚或电缆接点)</p> <p>(6). Either thermocouple or thermo-imaging (preferred) method may be used for temperature measurement. (热电或热成像(最佳)方法可用于测量温度)</p>	<p>The temperature rise of the outside shell surface of the mated pair above the VBUS and GND contacts shall not exceed 30°C above the ambient temperature. (在VBUS 与 GND PIN上方的外壳表面的温度上升不可超过环境温度30度)</p>  <p>Measurement Point: Receptacle shell top when a receptacle with a conductive shell is used</p>
---	---	--	--

 XB Connectivity	Doc. No.	SP-A0162-01	Page No.	6/19
	Date Issued	2015-04-06	Prepared by	Josephine
	Date revised	2018-11-23	checked by	Jay
Product Specification	Rev. No.	01	Approved by	Mei Chen
Title: USB TYPE C 3.1				

For certification, the connector manufacturer shall provide the receptacle and plug samples under test mounted on a current rating test PCB. The current rating test PCBs shall be of 2-layer construction. Table C-1 defines the requirements for the test PCB thickness and traces. The trace length applies to each PCB (receptacle PCB and plug PCB) and is from the contact terminal to the current source tie point. Figure C-2 provides an informative partial trace illustration of the current rating test PCB. (为了认证, 连接器制造商应提供安装在电流额定值测试板上的受测试插座和插头样品。额定电流测试电路板应为双层板。表 C-1 定义了测试 PCB 厚度和痕迹的要求。长度适用于每个 PCB (插座 PCB 和插头 PCB), 并且是从接触端到电流源连接点。图 C-2 提供了电流额定值测试 PCB 的部分图示)

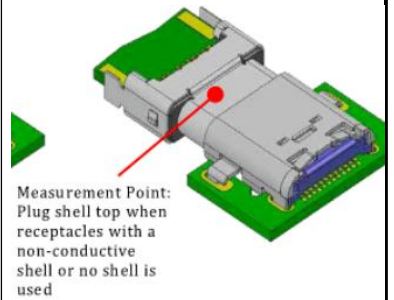
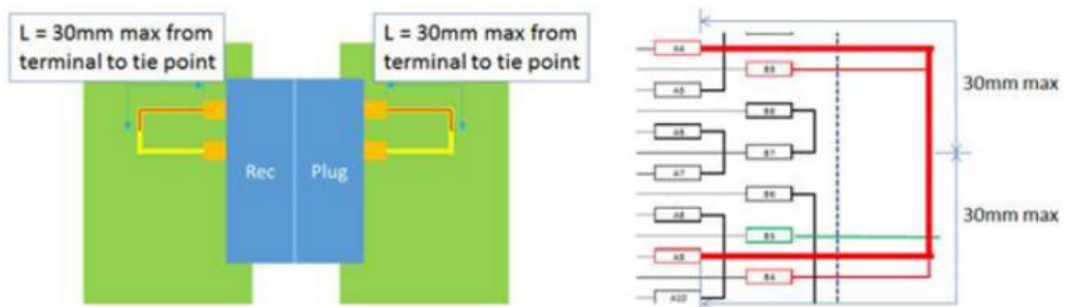



Table C-1 Current Rating Test PCB

Item	Trace width (mm)	Trace length (mm) on each PCB	Thickness
Signal trace	0.25 max.	13 max.	35 μ m (1 oz. copper)
Ground trace	1.57 max.	38 max.	35 μ m (1 oz. copper)
V _{BUS} and V _{CONN}	1.25 max.	30 max.	35 μ m (1 oz. copper)
PCB	N/A	N/A	0.80 – 1.20 mm

Figure C-2. Example Current Rating Test Fixture Trace Configuration



 XB Connectivity	Doc. No.	SP-A0162-01	Page No.	7/19
	Date Issued	2015-04-06	Prepared by	Josephine
	Date revised	2018-11-23	checked by	Jay
Product Specification	Rev. No.	01	Approved by	Mei Chen
Title: USB TYPE C 3.1				

7.3 MECHANICAL (机械)

ITEM	DESCRIPTION (类型)	TEST CONDITION (测试条件)	REQUIREMENT (要求)
1	Insertion Force (插入力)	EIA 364-13 The insertion force test shall be done at a maximum rate of 12.5 mm (0.492") per minute. (以最高每分钟 12.5mm(0.492")的速度测试)	5 ~ 20 N
2	Extraction Force (拔出力)	EIA 364-13 The extraction force test shall be done at a maximum rate of 12.5 mm (0.492") per minute. (以最高每分钟 12.5mm(0.492")的速度测试)	Within the range of 8 N to 20 N. from 1 to 1,000 cycles and within the range of 6 N to 20 N. from 1,001 to 5,000 cycles. (1 至 1000 次拔出力在 8N 至 20N 的范围内, 1001 至 5000 次拔出力在 6N 至 20N 的范围内)
3	Durability (耐久)	EIA 364-09 The durability test shall be done at a maximum rate of 200 cycles per hour. (以每小时200次的速度测试)	5,000 cycles minimum. Low level contact resistance and dielectric withstanding voltage shall be checked to be within spec after the 5,000 durability cycles. (最少 5,000 次循环。经过 5,000 次耐久循环后, 接触电阻和耐电压是否在规格范围内)
4	Cable Flexing (线材摇摆测试)	EIA 364-41, Condition 1 No physical damage or discontinuity over 1ms during flexing shall occur to the cable assembly with Dimension X = 3.7 times the cable diameter and 100 cycles in each of two planes. (电缆在两个面中作尺寸 x = 3.7 倍电缆直径的弯曲, 每个平面上做 100 次循环, 弯曲过程中, 电缆组件不得发生物理损坏或不连续性)	Appearance (外观) : No Damage (没有损坏) Discontinuity (断讯) : 1 μ sec maximum. (不能超过 1 微秒)

 XB Connectivity	Doc. No.	SP-A0162-01	Page No.	8/19
	Date Issued	2015-04-06	Prepared by	Josephine
	Date revised	2018-11-23	checked by	Jay
Product Specification	Rev. No.	01	Approved by	Mei Chen
Title: USB TYPE C 3.1				

5	Cable Pull-Out (电缆拉力测试)	EIA 364-38, Method A No physical damage to the cable assembly shall occur when it is subjected to a 40 N axial load for a minimum of 1 minute while clamping one end of the cable plug . (夹紧电缆插头的一端, 电缆承受 40n 轴向负荷至少 1 分钟时, 不会对电缆组件造成物理损坏)	Appearance (外观) : No Damage (没有损坏) Discontinuity (断讯) : 1 μ sec maximum. (不能超过1微秒)
6	4-Axis Continuity Test (四轴连续性测试)	See Appendix D for detailed test fixtures and procedures. Plug and Receptacle: Subject the mating interface to the moments defined in Figure D-1 & D-2 for at least 10 seconds. (详细的测试夹具和程序见附录 D, 插头和插座: 接口依图 D-1和 D-2中定义, 至少10秒钟)	No discontinuities greater than 1 microsecond duration in any of the four orientations tested. (在测试的四个方向中, 不能有任何断讯超过1微秒)

Figure D-1. Example of 4-Axis Continuity Test Fixture

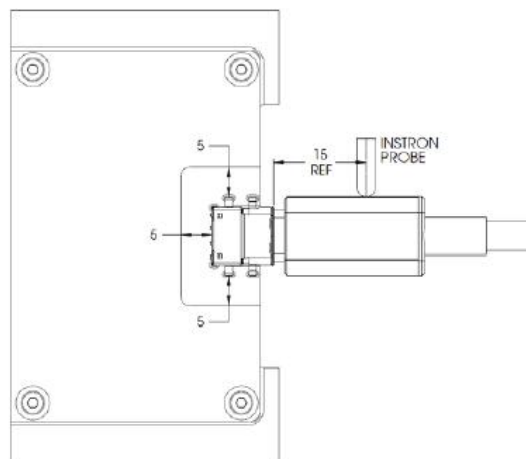

Plugs shall be supplied with a representative overmold or mounted on a 2-layer printed circuit board (PCB) between 0.8 mm and 1.0 mm thickness as applicable. A USB Type-C receptacle shall be mounted on a 2-layer PCB between 0.8 mm and 1.0 mm thickness. The PCB shall be clamped on three sides of the receptacle no further than 5 mm away from the receptacle outline. The receptacle PCB shall initially be placed in a horizontal plane, and a perpendicular moment shall be applied to the plug with a 5 mm ball tipped probe for a period of at least 10 seconds at a distance of 15 mm from the mating edge of the receptacle shell in a downward direction, perpendicular to the axis of insertion. See Table D-1 for the force and moment to be applied. (插头应配备有代表性的外模或安装在厚度在0.8毫米至1.0毫米之间的2层印刷电路板(PCB)上(如适用)。插座须安装在厚度0.8毫米至1.0毫米的两层电路板上。治具必须夹住印刷电路板的三面, 距离治具轮廓边不超过5毫米。插座PCB 应处在水平面上, 带有5毫米球头探头的夹头以垂直力矩作用于插头, 时间至少为10秒, 距对插插座外壳的边缘15毫米, 垂直于插入轴方向向下。有关力和力矩, 请参见表 D-1)



Doc. No.	SP-A0162-01	Page No.	9/19
Date Issued	2015-04-06	Prepared by	Josephine
Date revised	2018-11-23	checked by	Jay
Rev. No.	01	Approved by	Mei Chen

Product Specification

Title: USB TYPE C 3.1

Table D-1 Force and Moment Requirements

Receptacle configuration with respect to mounting surface	Force at 15 mm from receptacle shell mating edge (N)	Moment with respect to receptacle shell mating edge (Nm)
Right angle	20	0.30
Vertical	8	0.12

The continuity across each contact shall be measured throughout the application of the tensile force. Each non-ground contact shall also be tested to confirm that it does not short to the shell during the stresses. The PCB shall then be rotated 90 degrees such that the cable is still inserted horizontally and the 8 N tensile force shall be applied again in the downward direction and continuity measured as before. This test is repeated for 180 degree and 270 degree rotations. Passing parts shall not exhibit any discontinuities or shorting to the shell greater than 1 μ s duration in any of the four orientations. (在施加拉力的过程中, 应测量每个接触点的连续性。每个非接地脚也应进行测试, 以确保在应力作用期间不会缩到外壳上。然后将 PCB 旋转90度, 使电缆仍然水平插入, 以8N 的张力再次向下施加, 并像之前一样测量连续性。旋转180度和270度重复测试。通过的零件在任何一个方向上都不应表现出任何不连续性超过1秒的持续时间或与外壳短路。)

One method for measuring the continuity through the contacts is to short all the wires at the end of the cable pigtail and apply a voltage through a pull-up to each of VBUS, USB D+, USB D-, SBU, CC, and USB Super Speed pins, with the GND pins connected to ground. Alternate methods are allowed to verify continuity through all pins. (通过接触测量连续性的方法是短路电缆末端的所有导线, 并通过向每个 VBUS, USB D+, USB D-, SBU, CC 和 USB 高速PIN施加电压, GND PIN 连接到地面。备用方法是允许通过所有引脚验证可连续性)

The USB Type-C connector family shall be tested for continuity under stress using a test fixture shown in Figure D-2 or equivalent. (应使用图 D-2所示的测试夹具或同等物, 测试 USB Type-C 连接器系列在受压状态下的讯号连续性)

Table D-2

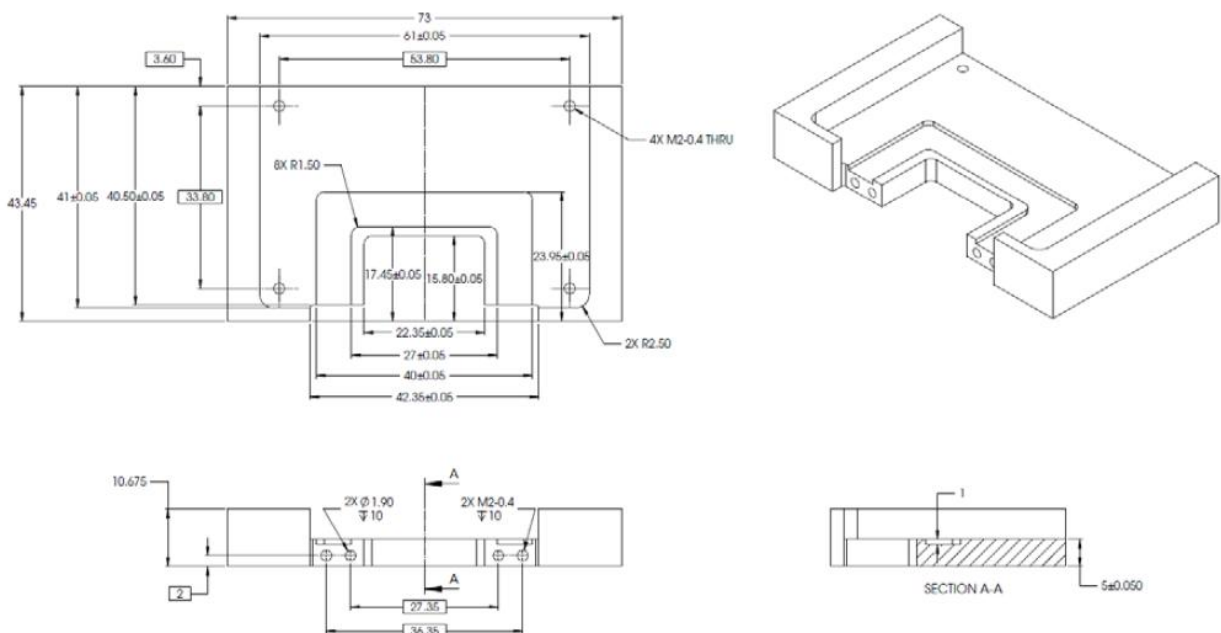



Doc. No.	SP-A0162-01	Page No.	10/19
Date Issued	2015-04-06	Prepared by	Josephine
Date revised	2018-11-23	checked by	Jay
Rev. No.	01	Approved by	Mei Chen

Product Specification

Title: USB TYPE C 3.1

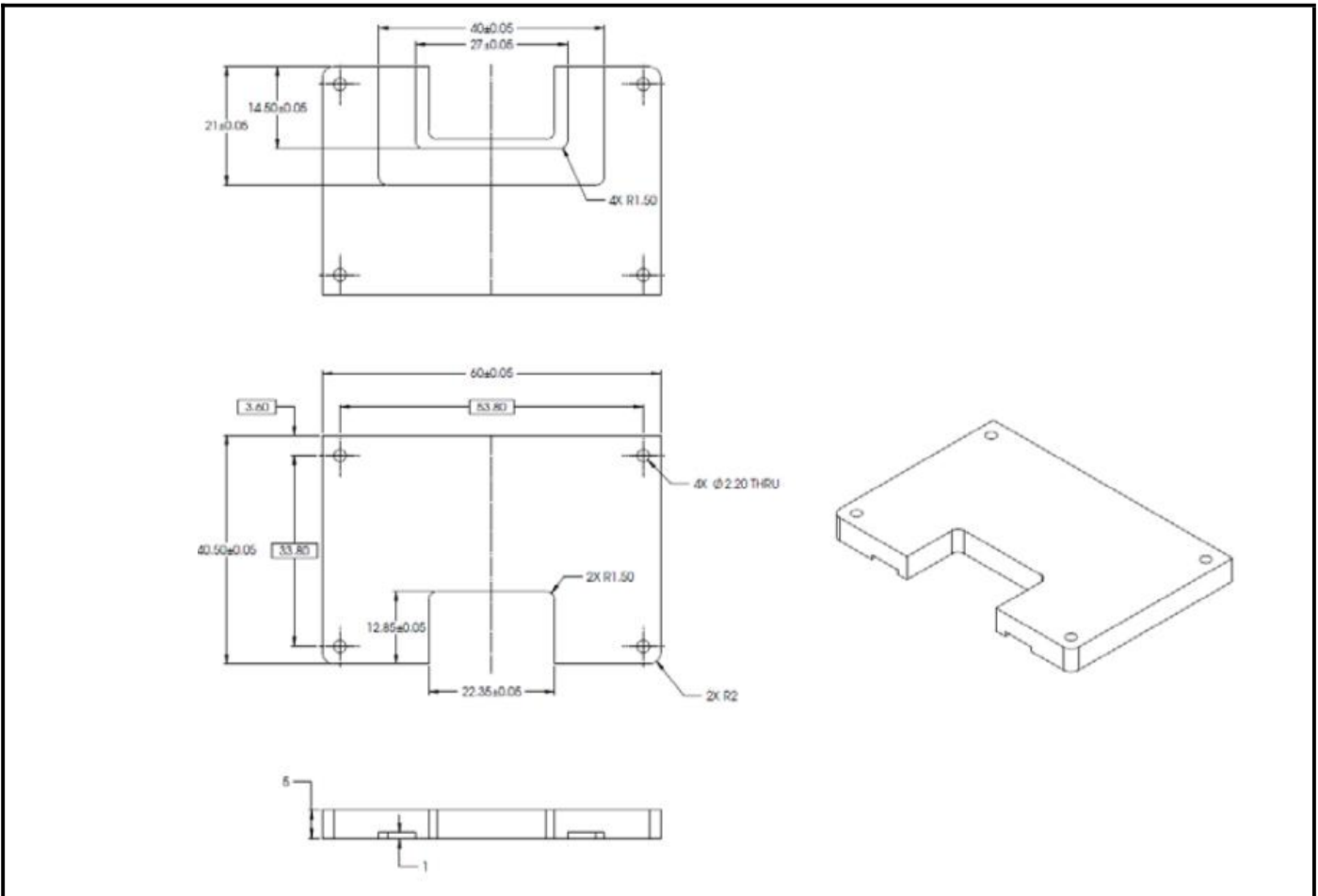

7	<p>Wrenching Strength (扭转力度测试)</p>	<p>Perpendicular forces are applied to the plug in four directions (i.e., left, right, up, and down). (垂直力作用于PLUG的四个方向(即, 左, 右, 上, 下))</p> <p>A metal fixture with opening and tongue representative of a receptacle shall be Used. (必须使用金属治具固定装置)</p> <p>A new plug is required for each of the four test directions. The plug shall disengage from the test fixture or demonstrate mechanical failure (i.e., the force applied during the test procedure peaks and drops off) when a moment of 2.0 Nm is applied to the plug in the up and down directions and a moment 3.5 Nm is applied to the plug in the left and right directions. (四个测试方向都需要一个新的插头。插头应从测试夹具上脱离或显示机械故障(即测试过程中施加的力峰值和下降), 当2.0 Nm 的力矩作用于插头的上下方向, 并且3.5 Nm 的力矩作用于插头的左右方向)</p>	<p>A single plug shall be used for this test. Some mechanical deformation may occur. The plug shall be mated with the continuity test fixture after the test forces have been applied to verify no damage has occurred that causes discontinuity or shorting.</p> <p>The dielectric withstanding voltage test shall be conducted after the continuity test to verify plug compliance. (插头与测试夹具配合, 一次测试只能使用一个插头。会发生机械变形。在施加测试力以验证不可发生导致不连续或短路的损坏之后。耐压测试须在连续性测试后进行, 以确保插头符合要求)</p>
---	---	---	--



Doc. No.	SP-A0162-01	Page No.	12/19
Date Issued	2015-04-06	Prepared by	Josephine
Date revised	2018-11-23	checked by	Jay
Rev. No.	01	Approved by	Mei Chen

Product Specification

Title: USB TYPE C 3.1

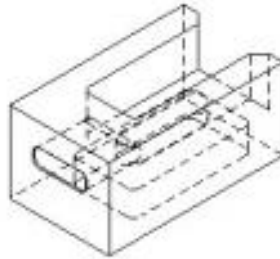

Receptacle body

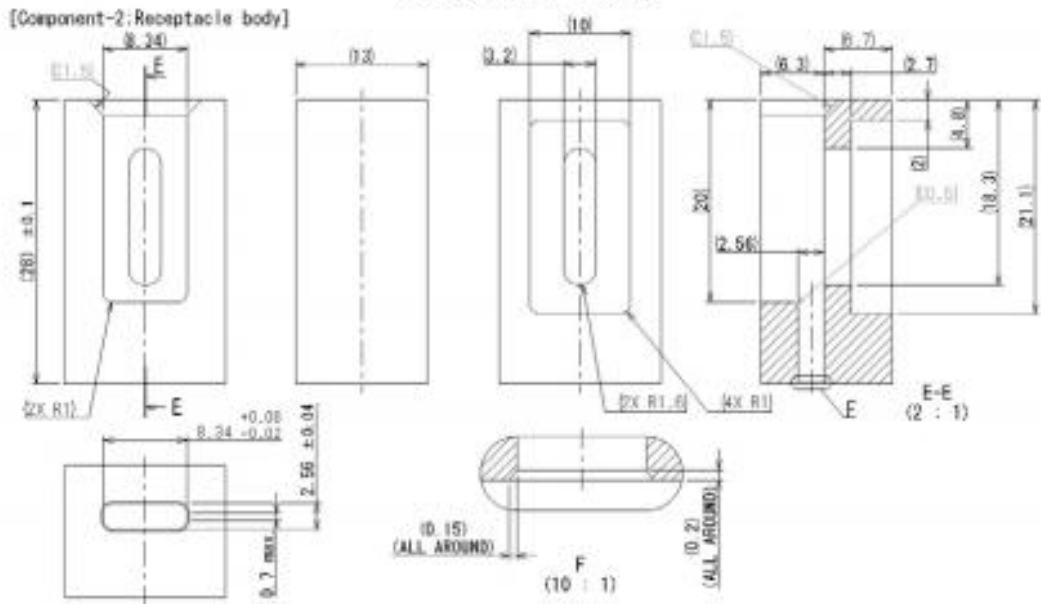

Screw + Washer (Ref.)

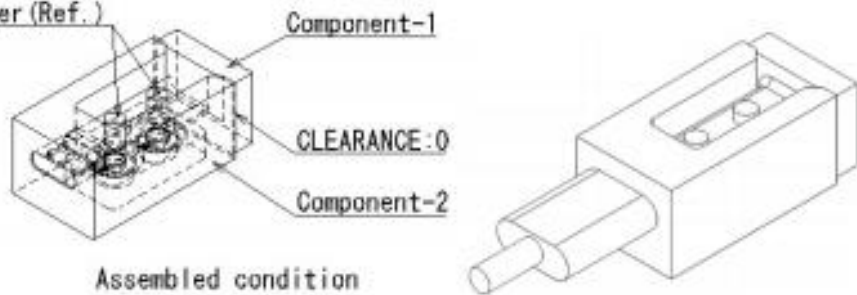

[Assembled test fixture]

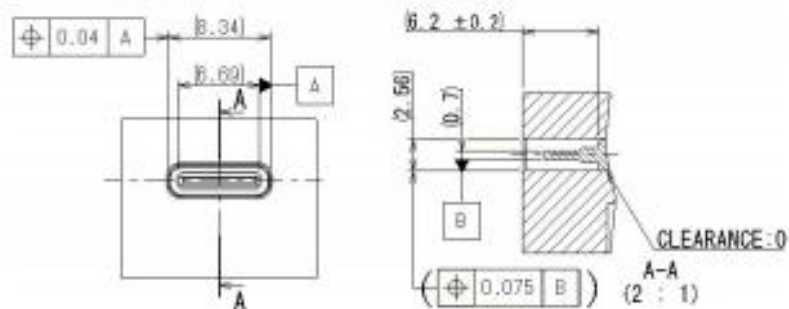



Figure D-3. Wrenching Strength Test Fixture

 XB Connectivity	Doc. No.	SP-A0162-01	Page No.	13/19
	Date Issued	2015-04-06	Prepared by	Josephine
	Date revised	2018-11-23	checked by	Jay
Product Specification	Rev. No.	01	Approved by	Mei Chen
Title: USB TYPE C 3.1				

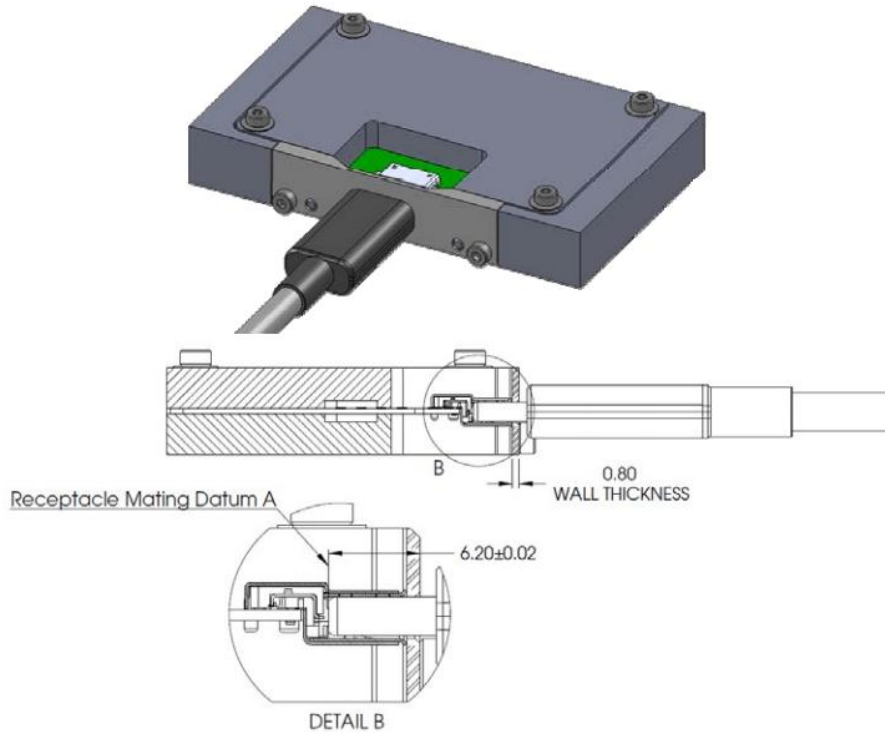

Figure D-4. Reference Wrenching Strength Continuity Test Fixture

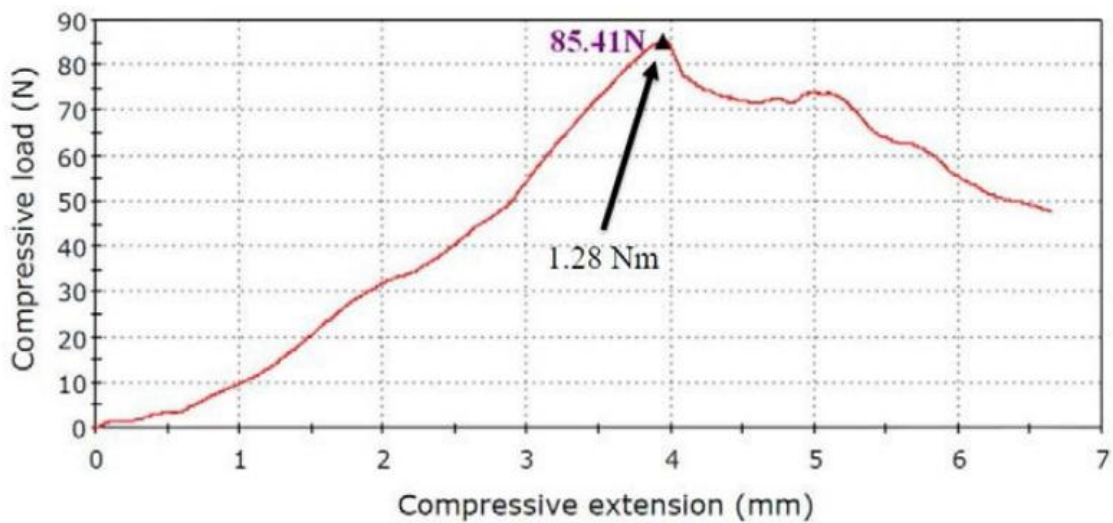



Figure D-5. Example of Wrenching Strength Test Mechanical failure point

 XB Connectivity	Doc. No.	SP-A0162-01	Page No.	14/19
	Date Issued	2015-04-06	Prepared by	Josephine
	Date revised	2018-11-23	checked by	Jay
Product Specification	Rev. No.	01	Approved by	Mei Chen
Title: USB TYPE C 3.1				

7.4 ENVIRONMENTAL (环境)

ITEM	DESCRIPTION (类型)	TEST CONDITION (测试条件)	REQUIREMENT (要求)
1	Temperature Life (温度寿命)	EIA 364-17, Method A. 105°C without applied voltage for 120 hours. (不加电压 105° C, 120 小时) 105°C without applied voltage for 72 hours when used as preconditioning. (预处理不加电压105° C, 72小时)	Low level contact resistance meets spec before and after the Temperature Life test. (接触电阻在温度寿命试验前后符合规格要求)
2	Vibration (振动)	EIA 364-28 Test Condition VII, Test Letter D Frequency (频率) : 10~55~10Hz Direction (方向) : X, Y, Z axis Amplitude (振幅) : 1.52mm Duration: 1 hours in each direction (每个方向各振动 1 小时)	No evidence of physical damages and no discontinuity longer than 1 microsecond. Low level contact resistance meets spec before and after the Vibration test. (没有物理损伤, 断讯超过 1 微秒。接触电阻符合规格振动前后测试)
3	Cyclic Temperature and Humidity (周期性温度和湿度)	EIA-364-31 Cycle the connector between 25 °C ±3°C at 80 % ±3% RH and 65 °C ±3 °C at 50 % ±3% RH. Ramp times should be 0.5 hour and dwell times should be 1.0 hour. Dwell times start when the temperature and humidity have stabilized within the specified levels. (在湿度 80% ± 3% RH 温度 25 ° C ± 3 ° C 和湿度 50% ± 3% RH 温度 65 ° C ± 3 ° C 之间循环。上升时间应该是 0.5 小时, 停留时间应该是 1 小时。停留时间开始时, 温度和湿度已经稳定在规定的水平。)	Perform 24 such cycles. (进行 24 次这样的循环)



Doc. No.	SP-A0162-01	Page No.	15/19
Date Issued	2015-04-06	Prepared by	Josephine
Date revised	2018-11-23	checked by	Jay
Rev. No.	01	Approved by	Mei Chen

Product Specification

Title: USB TYPE C 3.1

4	<p>Thermal Shock (热冲击)</p>	<p>EIA 364-32 Test Condition I The object of this test is to determine the resistance of a USB connector to exposure at extremes of high and low temperatures and to the shock of alternate exposures to these extremes, simulating the worst case conditions for storage, transportation and application. (10 Cycles -55°C and +85°C. The USB connectors under test must be mated. There shall be no evidence of damage.) (测试条件I 这个测试的目的是测定USB连接器在极端高温和极端低温下的耐受性, 以及在极端高温和极端低温下交替暴露的冲击性, 模拟储存、运输和应用的最坏情况条件。(10个循环 -55 ° C 和 + 85 ° C , 被测USB连接器必须配对。不应有任何损坏的证据。))</p>	<p>No evidence of any physical damage. Low level contact resistance meets spec before and after the Thermal Shock test. (没有任何物理损伤, 测试前后接触电阻符合规格。)</p>
5	<p>Mixed Flowing Gas (混合流动气体)</p>	<p>EIA 364-65, Class II A Samples should be placed in an environmentally controlled ‘test chamber’ that is monitored by a gas analyzing system for controlled concentrations of the specified gas mixture. Test coupons shall also be used and the weight gain reported. Test duration is 7 days. (样品放置在一个环境控制的试验箱, 由一个气体分析系统监测指定气体混合物的控制浓度, 还应使用试片, 并报告重量增加。 测试时间是 7 天。)</p>	<p>Low level contact resistance meets spec before and after the Mixed Flowing Gas test. (试验前后接触电阻符合规定)</p>
6	<p>Solder ability (可焊性)</p>	<p>EIA 364-52 Immerse the solder pin of the connector in solder bath at 245±5°C for 3±0.5sec. After dipped the pin in the flux 5sec. (将端子脚浸入助焊剂中 5 秒, 然后将端子脚浸入 245±5°C 的锡炉中 3±0.5 秒)</p>	<p>Solder wetting: 95% of immersed area must show voids, Pin holes. (锡附着面积应超过浸入面积的 95%以上)</p>



Doc. No.	SP-A0162-01	Page No.	16/19
Date Issued	2015-04-06	Prepared by	Josephine
Date revised	2018-11-23	checked by	Jay
Rev. No.	01	Approved by	Mei Chen

Product Specification

Title: USB TYPE C 3.1

7	Thermal disturbance (热扰动)	Cycle the connector or socket between 15 °C ±3 °C and 85 °C ± 3 °C, as measured on the part. Ramps should be a minimum of 2 °C per minute, and dwell times should insure that the contacts reach the temperature extremes (a minimum of 5 minutes). Humidity is not controlled. Perform 10 such cycles. (在15 °C ± 3 °C 和85 °C ± 3 °C 之间循环连接器。上升是每分钟至少2摄氏度, 停留时间应确保触点达到极端温度(至少5分钟)。湿度不受控制。进行10次这样的循环)	No evidence of any physical damage. Low level contact resistance meets spec before and after the test. (没有任何物理损伤, 测试前后接触电阻符合规格。)
8	Salt Spray (盐雾)	EIA 364-26 Connectors to 35+/-2°C. Humidity:85%(R.H). PH value:6.5~7.2 and 5+/-1% salt condition for 24hours. After test, rinse the sample with water and recondition the room temperature for 1 hour test CR and IR. (将连接器放置在 35±2°C, 温度为 85% PH 值 6.5~7.2 和 5%浓度的实验箱内测试 24 小时, 测试后用水清洗样品, 放置室温 1 小时测试接触阻抗与绝缘阻抗)	Appearance: No Damage (外观无损坏) No functional failures allowed. (不可有功能故障)
9	Resistance to Soldering heat (焊锡耐热性)	The contact of terminal shall be tested resistance to soldering heat in the following conditions. After Resistance to soldering heat test Contact Resistance. (端子应在下列条件下做耐吃锡性试验, 焊锡耐热性后试接触阻抗) In case of solder iron (2 time) 电烙铁(两次) Temperature 温度:350°C+/-5°C Time 时间: 5s+/-1s	Should not have any flaw scratch and crack. (无任何裂痕、刮伤和破裂)
10	IR-reflow (回流焊)	MIL-STD-202G method 210F Peak temperature time 260°C Max,10 sec or more. (峰值温度时间最高 260°C, 10 秒或以上) Duration : 2 cycles (过炉 2 次) Lead-Free Solder (无铅锡膏): Sn96.5Ag3Cu0.5 Refer to section 9 (请参阅第 9 条)	Should not have any flaw scratch and crack (无任何裂痕、刮伤和破裂) No visual damage to insulator. (绝缘体不得有严重变形)

 XB Connectivity	Doc. No.	SP-A0162-01	Page No.	17/19
	Date Issued	2015-04-06	Prepared by	Josephine
	Date revised	2018-11-23	checked by	Jay
Product Specification	Rev. No.	01	Approved by	Mei Chen
Title: USB TYPE C 3.1				

8. Product Qualification and TEST GROUP (产品验证和测试分组)

XB Connectivity TEST ITEM (测试项目)		TEST GROUP (测试分组)										
		A	B	C	D	E	F	G	H	I	J	K
		TEST SEQUENCE										
1	Appearance (外观)	1,8	1,8	1,5	1,5	1,9	1,6	1,7	1,8	1,9	1,7	1,6
2	Low Level Contact Resistance (接触电阻)	3,7	3,7	2,4	2,4	3,7	3,5	3,6	3,6	3,7	3,6	2,5
3	Dielectric Strength (耐电压)	5										
4	Insulation Resistance (绝缘电阻)	4				4,8			4,7	4,8		
5	Contact Current Rating (额定电流)	6										
6	Insertion Force (插入力)		4									
7	Extraction Force (拔出力)		5									
8	Durability (耐久)		6									
9	Cable Flexing (线材摇摆测试)			3								
10	Cable Pull-Out (电缆拉力测试)				3							
11	4-Axis Continuity Test (四轴连续性测试)					6						
12	Wrenching Strength (扭转力度测试)						4					
13	Vibration (振动)							4				
14	Temperature Life (温度寿命)							5				
15	Cyclic Temperature and Humidity (周期性温度和湿度)								5			
16	Thermal Shock (热冲击)									6		
17	Mixed Flowing Gas (混合流动气体)										5	
18	Solder ability (可焊性)									5		
19	Thermal disturbance (热扰动)										4	
20	Salt Spray (盐雾)											4
21	Reflow Soldering Heat Resistance (焊锡耐热性)											3
22	IR-reflow (回流焊)	2	2			2	2	2	2	2	2	
	Number of Samples Required (所需样本数目)	5										

 XB Connectivity	Doc. No.	SP-A0162-01	Page No.	18/19
	Date Issued	2015-04-06	Prepared by	Josephine
	Date revised	2018-11-23	checked by	Jay
Product Specification	Rev. No.	01	Approved by	Mei Chen
Title: USB TYPE C 3.1				

9. SOLDERING 焊接 :

9.1. Wave soldering (波峰焊) : DIP Suggestions solder temperature at 260°C (500°F) max.5 seconds . DIP 型推荐焊接焊锡温度为 260°C (500°F) 最多 5 秒

9.2. Hand soldering (手焊) : Use a soldering iron of 30 watts controlled at 350°C approximately 5 seconds. while applying solder.
使用 30W 烙铁控制温度在 350°C,焊接时长约 5 秒

9.3. Reflow soldering profile(回炉焊):When the maximum temperature of the reflow furnace is 260 °C and the temperature is 260 °c. 10 seconds MAX. (reference) SMT 型回焊炉最高温度为 260°C · 温度为 260°C时 , 最长时间不超过 10 秒 (如图)

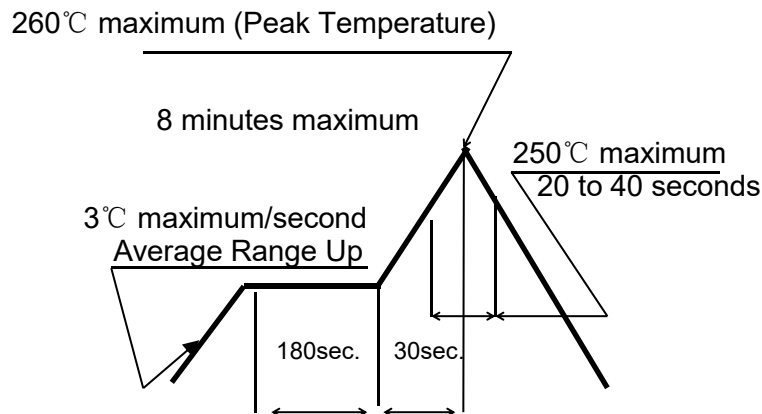

(Preheat Temperature 预热温度: 150~200°C Maximum.)
Temperature Condition Graph. 温度状态图
(Temperature on Board Pattern Side)

Requirement 要求: No physical damaged or plastic melting. 无物理损伤或塑料熔化

Rev.	Description	Date revised	Created/ Revised by
01	New Release	2015/04/30	Josephine Lin