



**标准&定制开关连接器产品制造商**  
DONG GUAN XI BANG ELECTRONICS CO., LTD.

# 规格书

## SPECIFICATION

CUSTOMER NAME 客户名称: \_\_\_\_\_  
 CUSTOMER NO. 客户编号: \_\_\_\_\_  
 SERIES 系列: 迷你型滑动开关  
 MODEL NO. 型号: XB-MSK-001D-3P  
 DRAWING NO. 图形号: Mini Slide Switch

If specification of this product meets your request, please confirm all the items of it and return to us with signature and stamp, it will be basis of our production and record. Thanks your cooperation in advance!

若此产品规格符合贵司要求，敬请确认此规格书内所有项目  
 并签名和盖章后回传给我司，以作我司产品制作之  
 依据和存档之用，多谢合作！

### EXAMINE & APPROVAL 审批

APPROVE 接受	NOT APPROVE 不接受
SIGNATURE 签署      STAMP 盖章      DATE 日期	

PREPARED BY. 制表人	CHECKED BY. 校对	APPROVED BY. 审核	APPROVAL BY. 批准
<div style="border: 1px solid red; padding: 2px;">研发部</div> <div style="border: 1px solid red; padding: 2px;">戴海明</div> <div style="border: 1px solid red; padding: 2px;">2022. 06. 08</div>	<div style="border: 1px solid red; padding: 2px;">品质部</div> <div style="border: 1px solid red; padding: 2px;">黄自清</div> <div style="border: 1px solid red; padding: 2px;">2022. 06. 08</div>	<div style="border: 1px solid red; padding: 2px;">工程部</div> <div style="border: 1px solid red; padding: 2px;">庞军</div> <div style="border: 1px solid red; padding: 2px;">2022. 06. 08</div>	<div style="border: 1px solid red; padding: 2px;">总经办</div> <div style="border: 1px solid red; padding: 2px;">吴量</div> <div style="border: 1px solid red; padding: 2px;">2022. 06. 08</div>

**东莞市溪榜电子有限公司**

**Dong guan Xi Bang Electronics Co., Ltd**

地址: 广东省东莞市黄江镇合路工业区  
 Address: He Lu Industrial Zone, Huangjiang Town  
 , Dongguan City, Guangdong Province  
 Tel: (0769)82055138/82056828  
 Fax: (0769)83663452

邮箱: admin@alspr.com    switch@alspr.com  
<http://www.alspr.cn/>    <http://www.alspr.com/>

**Dong Guan XB Electronics Co., Ltd**

AccountNumber: 705540238  
 BankName: Citibank N. A., HongKongBranch  
 Country/Region: Hong Kong  
 BankCode: 006  
 BankAddress: 3GardenRoad, Central, Hong Kong  
 SWIFT/BIC: CITIHKHX (CITIHKHXXXX\*If11charactersare  
 required)

MAil: HK@ALPSR.CN    XB@ALPSR.CN  
 Quality core! Afterburner for Made in China!

REV.	DESCRIPTION	APPROVED	DATE

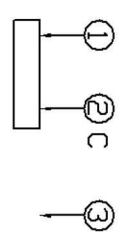

CIRCUIT DIAGRAM

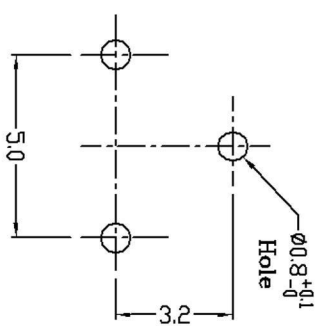
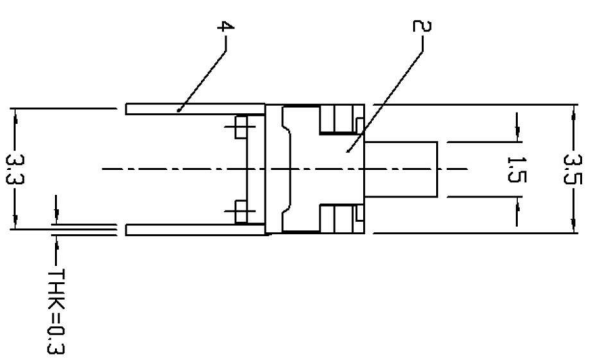
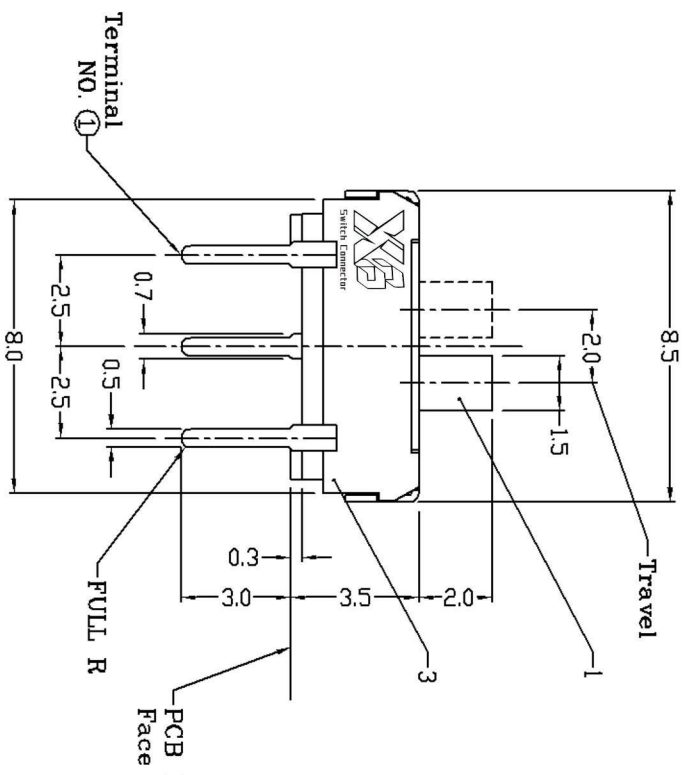

P.C. BOARD LAYOUT

NO.	PART NAME	MATERIAL	QTY.	FINISHING	TOLERANCES UNLESS OTHERWISE STATED			DO NOT SCALE THIS DRAWING			 东莞市溪榜电子有限公司 DONG GUAN XI BANG ELECTRONI CS CO., LTD.			
5	CONTACT CLIP	COPPER ALLOY	1	Ag CLAD	DIMENSIONAL			DRAWN	CHECKED	APPROVED	G D T	G D T	G D T	DATE
4	TERMINAL	BRASS STRIP	3	Ag PLATED	±0.2	ANGULAR	±3°	July-30/2007	July-30/2007	July-30/2007				
3	HOUSING	NYLON PA46	1	BLACK	PROJECTION			MODEL			XB-MSK-001D-3P			
2	METAL COVER	STAINLESS STEEL	1	NATURAL	ANGULAR			P/N			2007-JULY-30			
1	KNOB	NYLON PA46	1	WHITE	ANGULAR			DATE			REV.: A SCALE : 5 : 1 SIZE : A4			



**TITLE (产品系列): 3.5 (H) mm, 2mm-TRAVEL MINI SLIDE SWITCHES**

**MODEL NO. (产品名称): XB-MSK-001D-3P**

**P/N (产品编号):**

**1. RATING (额定值) : DC 6V 0.3A**

**2. FUNCTION (接触型式) : 1 POLE, 2 THROW**

**3. TIMING (时间特性) : NON-SHORTING**

**4. ELECTRICAL CHARACTERISTICS (电气性能规格):**

ITEM 项目	TEST CONDITIONS 测试条件	PERFORMANCE 规格
4.1 INITIAL CONTACT RESISTANCE 初始接触电阻	1000Hz MEASURED AT SMALL CURRENT (100 mA OR LESS) 在微小电流 (100mA) 以下测试。	70mΩ MAX. 70 毫欧以下。
4.2 INSULATION RESISTANCE 绝缘电阻	APPLY A VOLTAGE OF 500V DC FOR 1 MIN. TO FOLLOWING PORTIONS AFTER WHICH MEASUREMENT SHALL BE MADE: (1) BETWEEN BODY AND CONDUCTOR (2) BETWEEN CONDUCTORS NOT TO BE CONTACT 输入 500V DC 电压 1 分钟, 按以下接触方法测试: (1) 接触端子之间。 (2) 插座体与排脚之间。	100MΩ MIN. 100 兆欧以上。
4.3 DIELECTRIC STRENGTH 耐电压	AC 500V rms (50-60Hz) FOR 1 MIN TRIP CURRENT: 0.5 mA (1) BETWEEN TERMINALS. (2) BETWEEN INDIVIDUAL TERMINALS AND FRAME. 输入 AC 500V (50-60Hz) 电压, 1 分钟感度电流为 0.5 mA, 按以下接触方法测试: (1) 接触端子之间。 (2) 插座体与端子之间。	WITHOUT DAMAGE SUCH AS INSULATION BREAKDOWN. 没有绝缘破坏等异常。

**5. MECHANICAL CHARACTERISTICS (机械性能规格)**

ITEM 项目	TEST CONDITIONS 测试条件	PERFORMANCE 规格
5.1 OPERATING FORCE WITH DETENT 作动力		250gf ± 100gf
5.2 TERMINAL STRENGTH 端子强度	A STATIC LOAD OF (300gf) SHALL BE APPLIED TO THE TIP OF THE TERMINAL FOR 1 MIN. IN ANY DIRECTION. 在任意一个方向的先端上加力度 (300gf) 1 分钟。	ELECTRICAL CHARACTERISTICS SHALL BE SATISFIED WITHOUT DAMAGE OR EXCESSIVE LOOSENESS OF TERMINALS. 在排脚中没有裂开, 松动等异常, 满足于机械、电器性能。
5.3 STANDARD ATMOSPHERIC CONDITIONS 测试标准状态	UNLESS OTHERWISE SPECIFIED. THE STANDARD RANGE OF ATMOSPHERIC CONDITIONS FOR MAKING MEASUREMENTS AND TESTS ARE AS FOLLOWS: (1) AMBIENT TEMPERATURE: 5°C TO 35°C (2) RELATIVE HUMIDITY : 45% TO 85% (3) AIR PRESSURE : 80Kpa TO 106Kpa 在没有指定的情况下测试温度、湿度、气压如下: (1) 温度为 5~35°C (2) 湿度为 45%~85% (3) 气压为 80Kpa~106Kpa	



5.4	PRACTICAL TEMPERATURE RANGE 使用温度范围	-10°C~+60°C 在-10°C~+60°C温度内使用	
-----	---------------------------------------	----------------------------------	--

**6. ENDURANCE CHARACTERISTICS (耐久性):**

ITEM	项目	TEST CONDITIONS 测试条件	PERFORMANCE 规格
6.1	SOLDERABILITY TEST 可焊性试验	THE TOP OF THE TERMINALS SHALL BE DIPPED 2mm IN THE SOLDER BATH OF 230±5°C FOR 3±0.5 SECONDS. 端子顶部被浸入锡焊池中 2mm 深, 温度为 230±5°C, 时间为 3±0.5 秒.	THE AREA OF SOLDERING SHOULD BE OVER 75% 焊接面积要有 75%以上.
6.2	RESISTANCE TO SOLDERING HEAT TEST 耐焊性试验	SOLDER BATH METHOD: SOLDER TEMPERATURE 260±5°C IMMERSION TIME 3±0.5 SEC IMMERSION DEPTH UP TO THE SURFACE OF THE BOARD THICKNESS OF PRINTED WIRING BOARD 1 mm DIMENSIONS OF COMPONENT HOLES IN THE PRINTED WIRING BOARD SHALL BEING ACCORDANCE WITH THOSE SPECIFIED IN THIS SPECIFICATION. 焊炉焊接的时候温度控制在 260±5°C, 过炉时间为 3±0.5 秒, 于基板厚度为 1.0mm	THERE SHALL BE NO DEFORMATION OF THE SWITCH. MECHANICAL AND ELECTRICAL CHARACTERISTICS SHALL BE SATISFIED. 本体无变形, 满足于机械、电气性能。
6.3	LIFE TEST 寿命试验	WITHOUT LOAD: AN ACTUATOR SHALL BE SUBJECT TO 10,000 CYCLES AT A SPEED OF 15 TO 18 CYCLES FOR 1 MIN. 无负荷: 操作者以每分钟 15~18 次的频率作 10,000 回之无负荷测试.	(1) CONTACT RESISTANCE SHALL BE 130 mΩ MAX. (2) MECHANICAL AND ELECTRICAL CHARACTERISTICS SHALL BE SATISFIED. (1) 接触电阻不能超于 130 mΩ (2) 其它、满足于机械、电器性能



6.4	COLD TEST 耐冷试验	<p>THE SWITCH SHALL BE STORED AT A TEMPERATURE OF <math>-20\pm 3^{\circ}\text{C}</math> FOR 96 HOURS AND THEN IT SHALL BE SUBJECTED TO THE CONTROLLED RECOVERY CONDITIONS FOR 1 HOUR AFTER WHICH MEASUREMENT SHALL BE MADE.</p> <p>放置在温度 <math>-25\pm 3^{\circ}\text{C}</math> 中 96 小时后,再放置常温常湿中 1 小时来测定。</p>	<p>THERE SHALL BE NO DAMAGE ON APPEARANCE. MECHANICAL AND ELECTRICAL CHARACTERISTICS SHALL BE SATISFIED. 外观无异常, 满足于机械, 电器性能.</p>
6.5	HEAT TEST 耐热试验	<p>THE SWITCH SHALL BE STORED AT A TEMPERATURE OF <math>80\pm 2^{\circ}\text{C}</math> FOR 96 HOURS. AND THEN IT SHALL BE SUBJECTED TO THE CONTROLLED RECOVERY CONDITIONS FOR 1 HOUR AFTER WHICH MEASUREMENT SHALL BE MADE.</p> <p>放置在温度 <math>85\pm 2^{\circ}\text{C}</math> 中测试 96 小时后,再放置正常室温中 1 小时来测定。</p>	
6.6	HUMIDITY TEST 潮湿试验	<p>THE SWITCH SHALL BE STORED AT A TEMPERATURE OF <math>40\pm 2^{\circ}\text{C}</math> AND A HUMIDITY OF 90% TO 95% FOR 96 HOURS. THEN THE SWITCH SHALL BE MAINTAINED AT STANDARD ATMOSPHERIC CONDITION FOR 1 HOUR AFTER WHICH MEASUREMENT SHALL BE MADE.</p> <p>放置 <math>40\pm 2^{\circ}\text{C}</math> 的相对湿度为 90%~95% 环境中 96 小时后, 再将样版放在正常环境 1 小时后进行测试。</p>	